

Hoval RoofVent® RP

Operating instructions

Original operating
manual

4 222 626-en-00



| | | | |
|--|-----------|--|-----------|
| 1 Use | 3 | 7 Transport and installation | 33 |
| 1.1 Intended use | 3 | 7.1 Delivery | 33 |
| 1.2 User group | 3 | 7.2 Storage. | 35 |
| 2 Safety | 4 | 7.3 Requirements for the installation site | 36 |
| 2.1 Symbols | 4 | 7.4 Installing the heat pump | 38 |
| 2.2 Operational safety | 4 | 7.5 Installing the RoofVent® RP unit | 39 |
| 2.3 Decommissioning. | 5 | 7.6 Connecting air ducts and Air-Injectors | 45 |
| 3 Construction and operation | 6 | 7.7 Refrigeration system installation | 46 |
| 3.1 Construction. | 6 | 7.8 RoofVent® condensate connection | 51 |
| 3.2 Function | 8 | 7.9 Heat pump condensate connection | 51 |
| 3.3 Operating modes | 11 | 7.10 Electrical installation | 52 |
| 4 Type code | 14 | 8 Operation | 56 |
| 5 Technical data | 16 | 8.1 Initial commissioning | 56 |
| 5.1 Application limits | 16 | 8.2 Operation | 56 |
| 5.2 Electrical connection | 17 | 9 Maintenance and repair | 57 |
| 5.3 Air flow rate | 17 | 9.1 Safety | 57 |
| 5.4 Air filtration | 17 | 9.2 Maintenance. | 57 |
| 5.5 Heat recovery system (HRS) | 17 | 9.3 Repair | 59 |
| 5.6 Technical data of the heat pump | 18 | 10 Dismantling | 60 |
| 5.7 Heat output | 19 | 11 Disposal | 60 |
| 5.8 Cooling capacity | 19 | | |
| 5.9 Sound level | 20 | | |
| 5.10 Dimensions and weights | 22 | | |
| 6 Options | 30 | | |
| 6.1 Connection module | 30 | | |
| 6.2 Design with 2 Air-Injectors | 30 | | |
| 6.3 Design without Air-Injector | 30 | | |
| 6.4 Paint finish of below-roof unit | 30 | | |
| 6.5 Fresh air and exhaust air silencers | 31 | | |
| 6.6 Supply air and extract air silencers | 32 | | |
| 6.7 Condensate pump | 32 | | |
| 6.8 Socket | 32 | | |
| 6.9 Energy monitoring | 32 | | |

1 Use

1.1 Intended use

RoofVent® RP units are supply and extract air handling units for heating and cooling spaces up to 25 m in height with decentralised heat pump. They have the following functions:

- Fresh air supply
- Extract air removal
- Heating and cooling with heat pump
- Energy recovery with highly efficient plate heat exchanger
- Filtering of the fresh air and the extract air
- Air distribution and destratification with adjustable Air-Injector

The RoofVent® RP unit complies with all the requirements of the Ecodesign Directive 2009/125/EC relating to environmentally friendly design of ventilation systems. It is a system of the «non-residential ventilation unit» (NRVU) and «bidirectional ventilation unit» (BVU) type, provided for in Commission Regulation (EU) 1253/2014.

Intended use also includes compliance with the operating instructions. Any usage over and above this use is considered to be not as intended. The manufacturer can accept no liability for damage resulting from improper use.

1.2 User group

The units are only allowed to be installed, operated and maintained by authorised and instructed personnel who are well acquainted with the units and are informed about possible dangers.

The operating instructions are for operating engineers as well as specialists in building, heating and ventilation technology.

2 Safety

2.1 Symbols

**Caution**

This symbol warns against risk of injury. Please heed all instructions designated by this symbol to prevent injuries and/or death.

**Attention**

This symbol warns against property damage. Please heed the respective instructions to prevent risk of damage to the unit and its functions.

**Notice**

This symbol denotes information about the economic use of the equipment or special tips.

2.2 Operational safety

RoofVent® units are state-of-the-art design and are safe to operate. All control and safety valves are checked at the factory. Nevertheless, hazards may emanate from the units if they are used incorrectly or not used as intended. Therefore:

- The unit may only be installed, operated and serviced by authorised, trained and instructed skilled personnel:
 - Specialists as defined by these operating instructions are those persons who, based on their training, knowledge and experience as well as their knowledge of the relevant regulations and guidelines, can carry out the work assigned to them and recognise potential hazards.
- Please read the operating instructions before unpacking, installing, commissioning and before maintaining the equipment.
- Store the operating instructions so that they are easily accessible.
- Observe any attached information and warning signs.
- Immediately replace damaged or removed informational and warning signs.
- Follow the local safety and accident prevention regulations at all times.
- Observe the particular dangers involved in working on the roof and on electrical systems.
- When working on the unit, objects (e.g. tools) could be dropped. Block off the area underneath the unit.
- Do not attach additional loads to the unit.
- When working in the unit, take precautions against unprotected, sharp metal edges.
- Wear suitable protective equipment (helmet, gloves, mouth protection, goggles).
- Following maintenance work, professionally reassemble all dismantled protective devices.
- Ensure that all access doors are properly closed to prevent water entry through the roof unit.
- Replacement parts must comply with the technical requirements of the system manufacturer. Hoval recommends the use of original spare parts.
- Unauthorised reconfiguration or modification of the unit is not permitted.
- Shut down the unit immediately, if any defects are ascertained that limit the operational safety.

2.3 Decommissioning

Disconnect the power supply with the main switch in the control panel.

**Caution**

The use of condensers can pose a danger of fatal injury from directly touching live parts even after the unit is switched off. Only open the access doors after waiting 3 minutes.

3 Construction and operation

3.1 Construction

The RoofVent® RP unit consists of the following components:

- Roof unit with energy recovery
- Below-roof unit
- Heat pump system

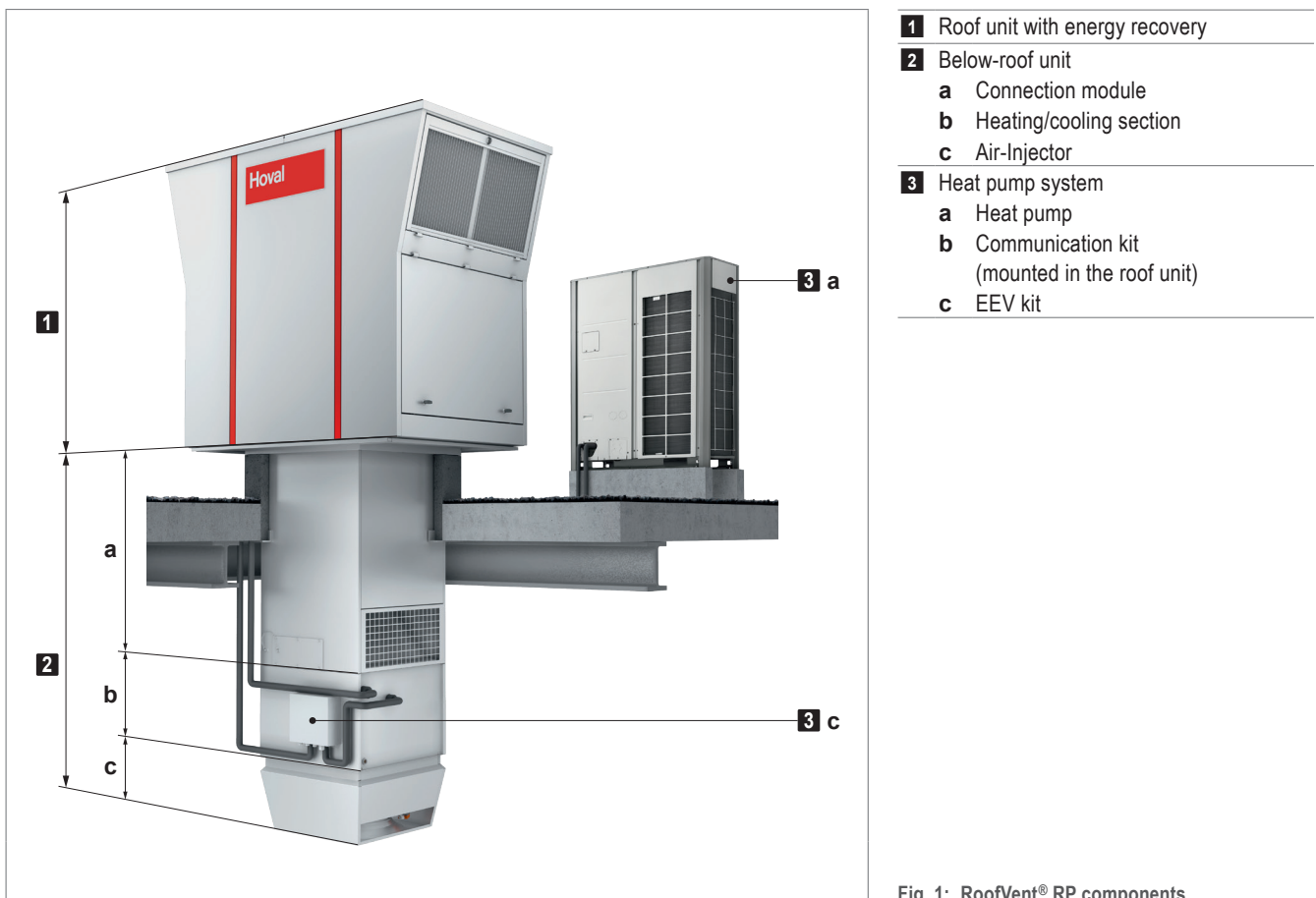
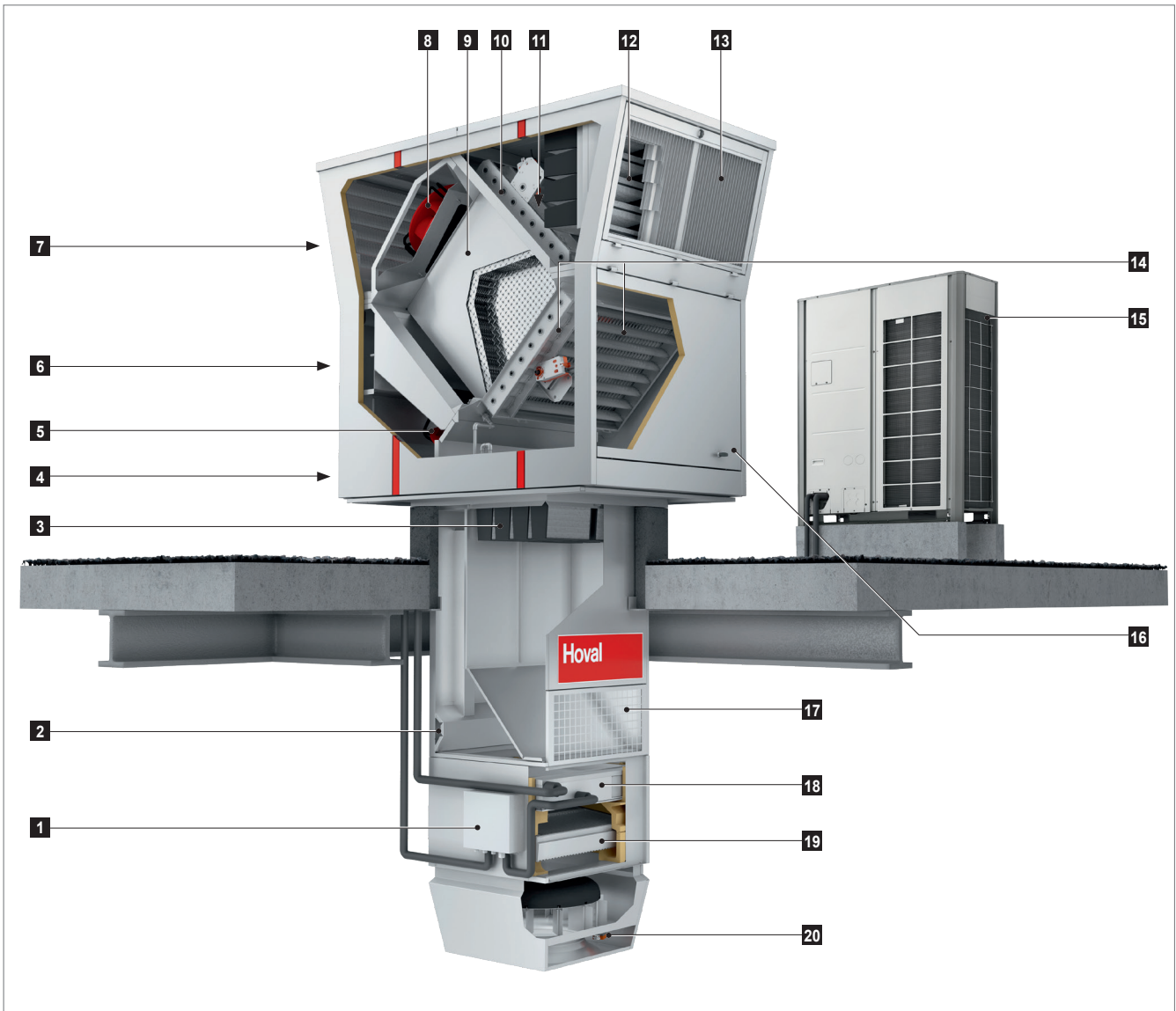

Fig. 1: RoofVent® RP components



Notice

The picture only shows the schematic layout. In contrast to the illustration here, the EEV kit is located on the refrigerant connection side.



- | | |
|--|---|
| <ul style="list-style-type: none"> 1 EEV kit with expansion valve 2 Connection box 3 Extract air filter 4 Supply air access door 5 Supply air fan 6 Control block with communication kit 7 Exhaust air access door 8 Exhaust air fan 9 Plate heat exchanger with bypass (for performance control and as recirculation bypass) 10 Bypass damper with actuator | <ul style="list-style-type: none"> 11 Fresh air damper with actuator 12 Fresh air filter 13 Fresh air access door 14 Extract air and recirculation dampers with actuator 15 Heat pump 16 Extract air access door 17 Extract air grille 18 Heating/cooling coil 19 Condensate separator 20 Actuator Air-Injector |
|--|---|

Fig. 2: RoofVent® RP construction

i Notice
The picture only shows the schematic layout. In contrast to the illustration here, the EEV kit is located on the refrigerant connection side.

3.2 Function

RoofVent® RP-6-P

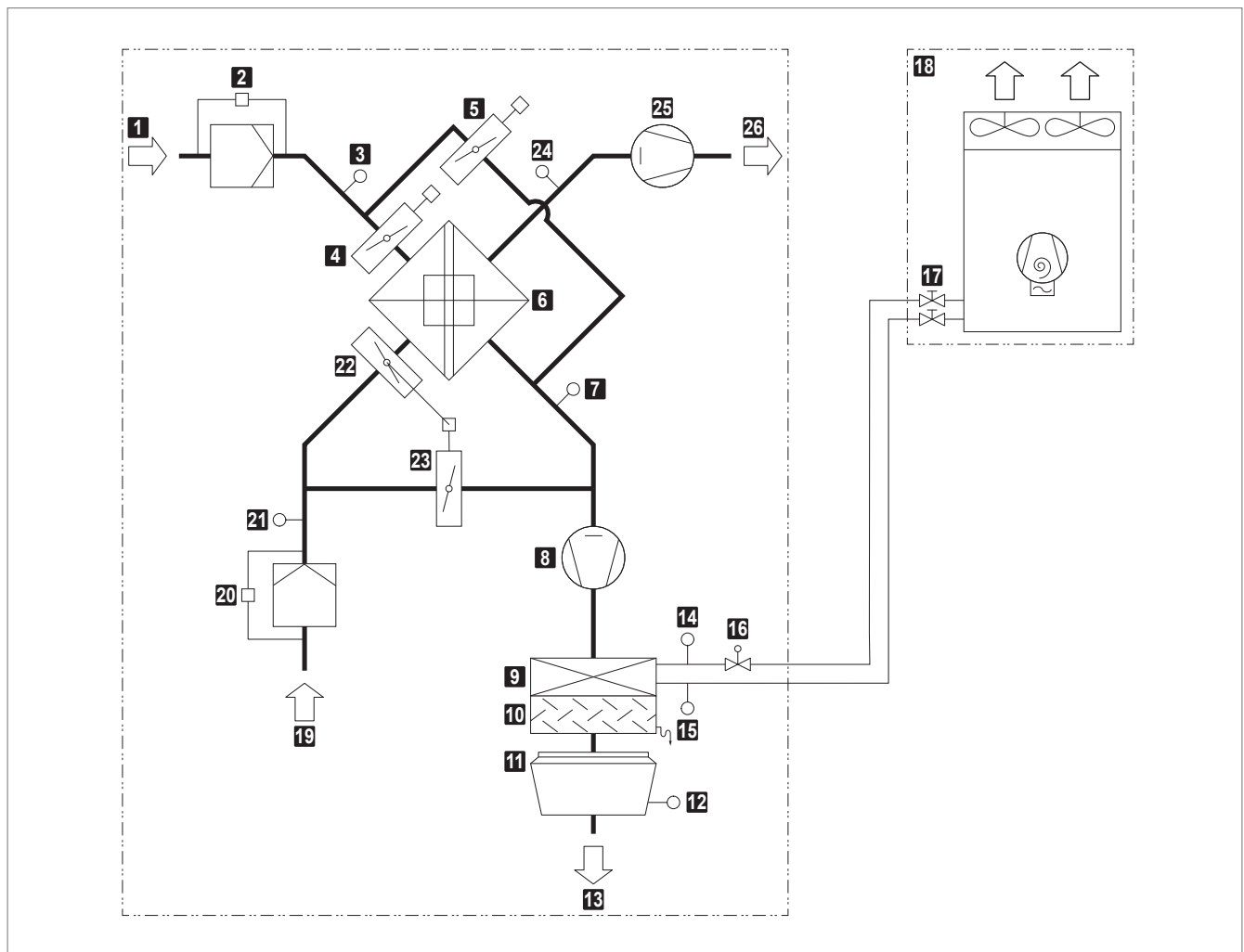

| | | | |
|-----------|--|-----------|--|
| 1 | Fresh air | 14 | Liquid temperature sensor (supplied loose) |
| 2 | Fresh air filter with differential pressure switch | 15 | Gas temperature sensor (supplied loose) |
| 3 | Temperature sensor air inlet ER (optional) | 16 | Expansion valve (supplied loose in the EEV kit) |
| 4 | Fresh air damper with actuator | 17 | Shut-off valves |
| 5 | Bypass damper with actuator | 18 | Heat pump P |
| 6 | Plate heat exchanger | 19 | Extract air |
| 7 | Temperature sensor air outlet ER (optional) | 20 | Extract air filter with differential pressure switch |
| 8 | Supply air fan with flow rate monitoring | 21 | Extract air temperature sensor |
| 9 | Heating/cooling coil | 22 | Extract air damper with actuator |
| 10 | Condensate separator | 23 | Recirculation damper (opposed to the extract air damper) |
| 11 | Air-Injector with actuator | 24 | Exhaust air temperature sensor |
| 12 | Supply air temperature sensor | 25 | Exhaust air fan with flow rate monitoring |
| 13 | Supply air | 26 | Exhaust air |

Table 1: RoofVent® RP-6-P function diagram

RoofVent® RP-9-P

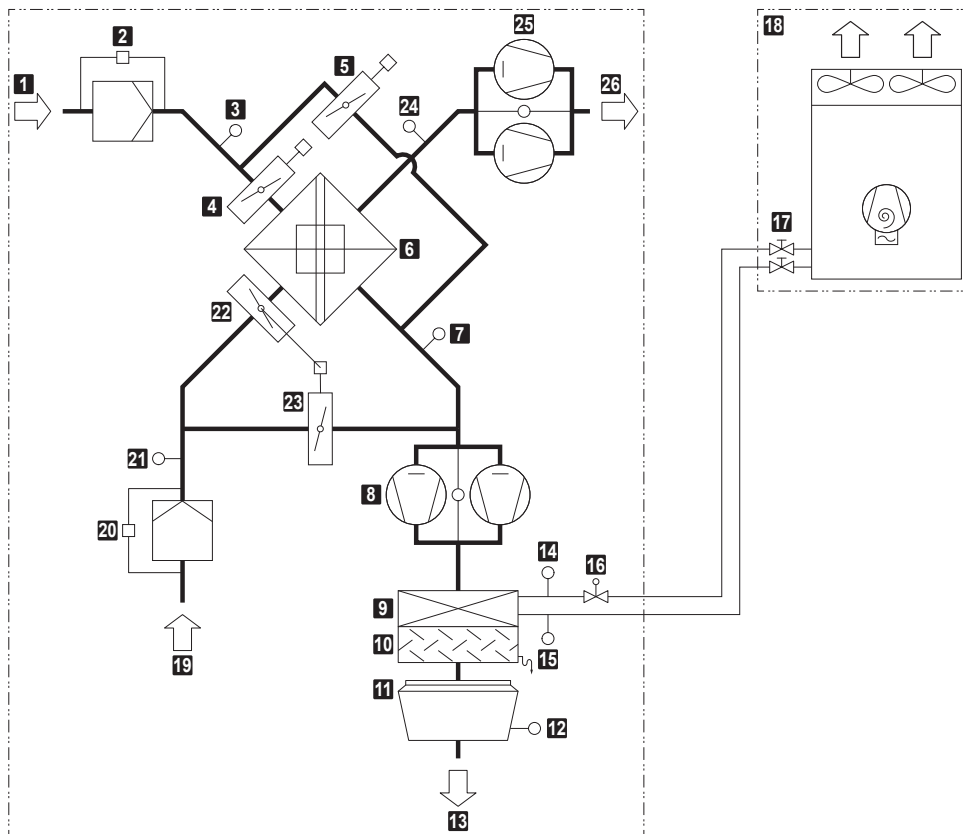

| | |
|---|--|
| 1 Fresh air | 14 Liquid temperature sensor (supplied loose) |
| 2 Fresh air filter with differential pressure switch | 15 Gas temperature sensor (supplied loose) |
| 3 Temperature sensor air inlet ER (optional) | 16 Expansion valves (supplied loose in the EEV kit) |
| 4 Fresh air damper with actuator | 17 Shut-off valves |
| 5 Bypass damper with actuator | 18 Heat pump P |
| 6 Plate heat exchanger | 19 Extract air |
| 7 Temperature sensor air outlet ER (optional) | 20 Extract air filter with differential pressure switch |
| 8 Supply air fans with flow monitoring | 21 Extract air temperature sensor |
| 9 Heating/cooling coil | 22 Extract air damper with actuator |
| 10 Condensate separator | 23 Recirculation damper (opposed to the extract air damper) |
| 11 Air-Injector with actuator | 24 Exhaust air temperature sensor |
| 12 Supply air temperature sensor | 25 Exhaust air fans with flow rate monitoring |
| 13 Supply air | 26 Exhaust air |

Table 2: RoofVent® RP-9-P function diagram

RoofVent® RP-9-Q

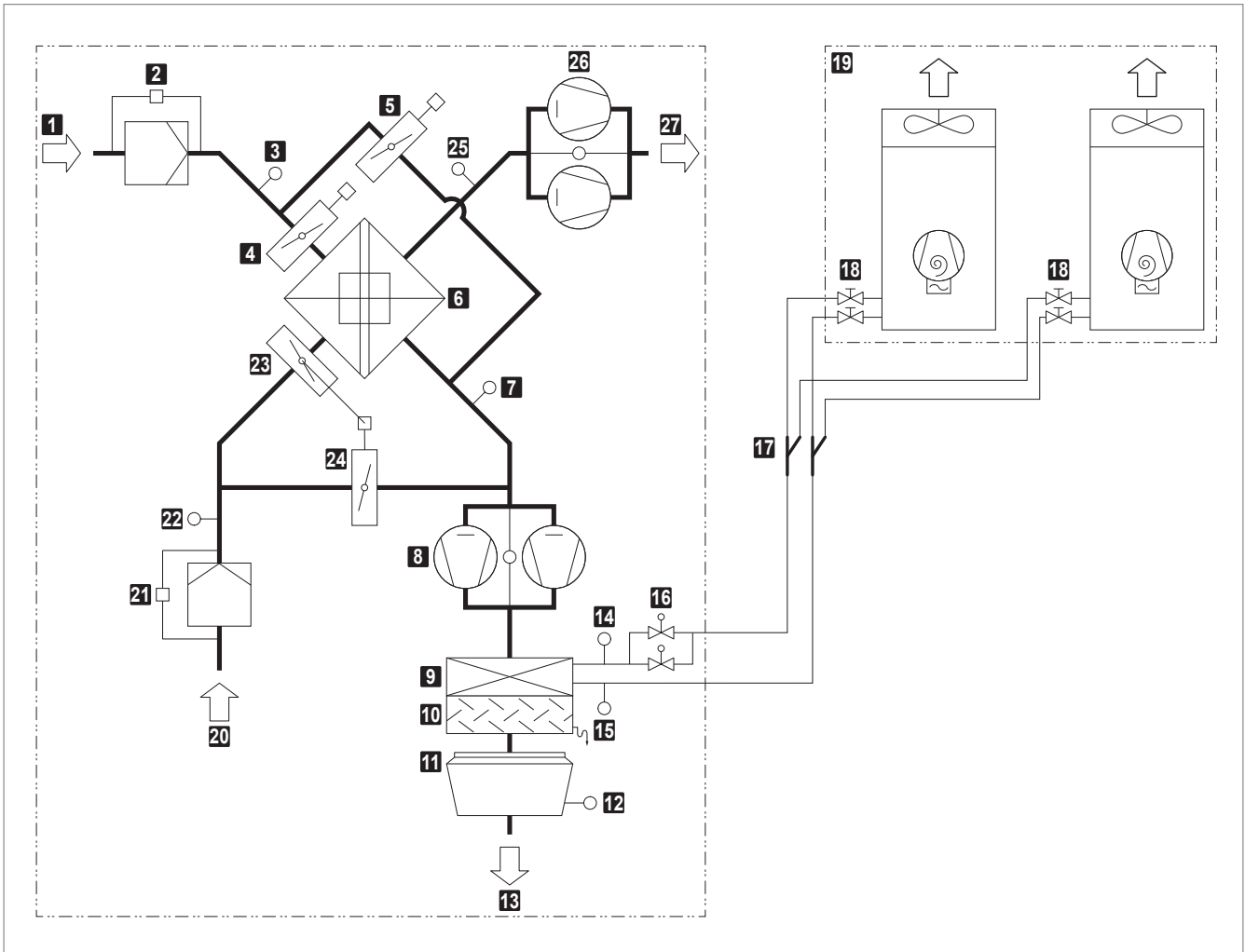

| | |
|---|--|
| 1 Fresh air | 15 Gas temperature sensor (supplied loose) |
| 2 Fresh air filter with differential pressure switch | 16 Expansion valves (supplied loose in the EEV kit) |
| 3 Temperature sensor air inlet ER (optional) | 17 Branch joint kit Q (supplied loose) |
| 4 Fresh air damper with actuator | 18 Shut-off valves |
| 5 Bypass damper with actuator | 19 Heat pump Q (cascade) |
| 6 Plate heat exchanger | 20 Extract air |
| 7 Temperature sensor air outlet ER (optional) | 21 Extract air filter with differential pressure switch |
| 8 Supply air fans with flow monitoring | 22 Extract air temperature sensor |
| 9 Heating/cooling coil | 23 Extract air damper with actuator |
| 10 Condensate separator | 24 Recirculation damper (opposed to the extract air damper) |
| 11 Air-Injector with actuator | 25 Exhaust air temperature sensor |
| 12 Supply air temperature sensor | 26 Exhaust air fans with flow rate monitoring |
| 13 Supply air | 27 Exhaust air |
| 14 Liquid temperature sensor (supplied loose) | |

Table 3: RoofVent® RP-9-Q function diagram

3.3 Operating modes

The RoofVent® RP has the following operating modes:

- Ventilation
- Ventilation (reduced)
- Air quality
- Recirculation
- Exhaust air
- Supply air
- Standby

The TopTronic® C control system regulates these operating modes automatically for each control zone in accordance with the specifications in the calendar. The following points also apply:

- The operating mode of a control zone can be switched over manually.
- Each RoofVent® unit can operate individually in a local operating mode: Off, Recirculation, Supply air, Exhaust air, Ventilation.

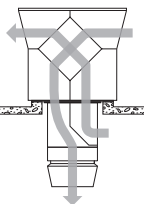
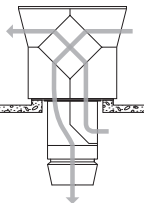
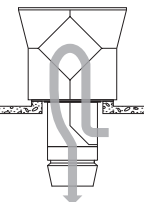
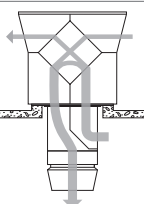
| Code | Operating mode | | Description |
|--------|---|--|--|
| VE | <p>Ventilation</p> <p>The unit blows fresh air into the room and exhausts polluted room air. The room temperature set value day is active. Depending on the temperature conditions, the system continuously controls:</p> <ul style="list-style-type: none"> ■ the energy recovery ■ the heating/cooling |  | <p>Supply air fan on ¹⁾</p> <p>Exhaust air fan on ¹⁾</p> <p>Energy recovery 0-100 %</p> <p>Extract air damper open</p> <p>Recirculation damper closed</p> <p>Heating/cooling 0-100 %</p> <p>¹⁾ Adjustable flow rate</p> |
| VEL | <p>Ventilation (reduced)</p> <p>As VE, but the unit only operates with the set minimum values for the supply and exhaust air volumes</p> |  | <p>Supply air fan MIN</p> <p>Exhaust air fan MIN</p> <p>Energy recovery 0-100 %</p> <p>Extract air damper open</p> <p>Recirculation damper closed</p> <p>Heating/cooling 0-100 %</p> |
| AQ | <p>Air quality</p> <p>This is the operating mode for demand-controlled ventilation of the room. The room temperature set value day is active. Depending on the temperature conditions, the system continuously controls:</p> <ul style="list-style-type: none"> ■ the energy recovery ■ the heating/cooling <p>Depending on the room air quality or room air humidity, the system operates in one of the following operating states:</p> | | |
| AQ_REC | <ul style="list-style-type: none"> ■ Air quality Recirculation: When air quality is good and air humidity appropriate, the unit heats or cools in recirculation operation. |  | Like REC |
| AQ_ECO | <ul style="list-style-type: none"> ■ Air quality Mixed air: When ventilation requirements are medium, the unit heats or cools in mixed air operation. The supply and exhaust air volume is based on the air quality. |  | <p>Supply air fan MIN-MAX</p> <p>Exhaust air fan MIN-MAX</p> <p>Energy recovery 0-100 %</p> <p>Extract air damper 50 %</p> <p>Recirculation damper 50 %</p> <p>Heating/cooling 0-100 %</p> |

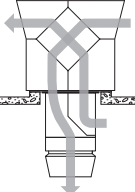
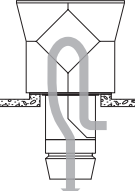
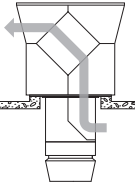
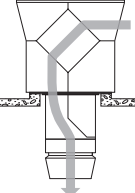
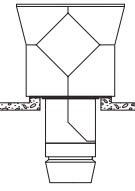
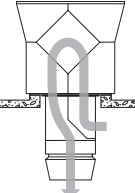
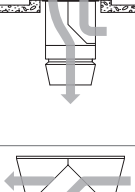
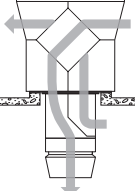
| | | | |
|----------------|---|--|---|
| AQ_VE | <ul style="list-style-type: none"> ■ Air quality Ventilation: When ventilation requirements are high or the room air humidity is too high, the unit heats or cools in pure ventilation operation. The supply and exhaust air volume is based on the air quality. |  | Supply air fan MIN-MAX Exhaust air fan MIN-MAX Energy recovery 0-100 % Extract air damper open Recirculation damper closed Heating/cooling 0-100 % |
| REC DES | <p>Recirculation On/Off recirculation operation with TempTronic algorithm: During heat or cool demand, the unit draws in room air, heats or cools it and blows it back into the room. The room temperature set value day is active. The flow rate is controlled in 2 stages.</p> <ul style="list-style-type: none"> ■ Destratification: To avoid heat build-up under the ceiling, it may be appropriate to switch on the fan when there is no heat demand (either in permanent operation or in on/off operation depending on the temperature stratification, as desired). |  | Supply air fan 0 / MIN / MAX ¹⁾ Exhaust air fan off Energy recovery 0 % Extract air damper closed Recirculation damper open Heating/cooling on ¹⁾ ¹⁾ Depending on heat or cool demand |
| EA | <p>Exhaust air The unit extracts spent room air. There is no room temperature control. Unfiltered fresh air enters the room through open windows and doors or another system provides air supply.</p> |  | Supply air fan off Exhaust air fan on ¹⁾ Energy recovery 0 % Extract air damper open Recirculation damper closed Heating/cooling off ¹⁾ Adjustable flow rate |
| SA | <p>Supply air The unit blows fresh air into the room. The room temperature set value day is active. Depending on the temperature conditions, the system controls the heating/cooling. Spent room air passes through open windows and doors or another system provides extraction.</p> |  | Supply air fan on ¹⁾ Exhaust air fan off Energy recovery 0 % ²⁾ Extract air damper open Recirculation damper closed Heating/cooling 0-100 % ¹⁾ Adjustable flow rate ²⁾ Fresh air and bypass dampers are open |
| ST | <p>Standby The unit is ready for operation. The following operating modes are activated if required:</p> |  | |
| CPR | <ul style="list-style-type: none"> ■ Cooling protection: If the room temperature drops below the set value for cooling protection, the unit heats up the room in recirculation operation. |  | Supply air fan MAX Exhaust air fan off Energy recovery 0 % Extract air damper closed Recirculation damper open Heating/cooling on |
| OPR | <ul style="list-style-type: none"> ■ Overheating protection: If the room temperature rises above the set value for overheating protection, the unit cools down the room in recirculation operation. If the temperatures also permit fresh air cooling, the unit automatically switches to night cooling (NCS) to save energy. |  | Supply air fan on ¹⁾ Exhaust air fan on ¹⁾ Energy recovery 0 % Extract air damper open Recirculation damper closed Heating/cooling off |
| NCS | <ul style="list-style-type: none"> ■ Night cooling: If the room temperature exceeds the set value for night cooling and the current fresh air temperature permits it, the unit blows cool fresh air into the room and extracts warmer room air. |  | Supply air fan on ¹⁾ Exhaust air fan on ¹⁾ Energy recovery 0 % Extract air damper open Recirculation damper closed Heating/cooling off ¹⁾ Adjustable flow rate |

| | | | |
|---------------------|---|--|---|
| <p>L_OFF</p> | <p>Off (local operating mode) The unit is switched off; frost protection remains active.</p> |  | <p>Supply air fan off Exhaust air fan off Energy recovery 0 % Extract air damper closed Recirculation damper open Heating/cooling off</p> |
|---------------------|---|--|---|

Table 4: RoofVent® RP operating modes

4 Type code

RP - 6 - P - RX / ST . -- / V0 . D1 . LU / AF . SI / - . KP . -- . SD / TC . EM . -- . --

Unit type

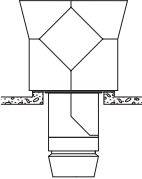
RoofVent® RP

Unit size

6 or 9

Heating/cooling section

- P with coil type P for heat pump P
- Q with coil type Q for heat pump Q (only for size 9)

Heat recovery

RX Temperature efficiency ErP 2018

Design

ST Standard

Connection module

- V0 Standard
- V1 Length + 250 mm
- V2 Length + 500 mm
- V3 Length + 1000 mm

Air outlet

- D1 Design with 1 Air-Injector
- D2 Design with 2 Air-Injectors
- D0 Design without Air-Injector

Paint finish

- without
- LU Paint finish of below-roof unit

Silencers outside

- without
- AF Fresh air and exhaust air silencers

Silencers inside

- without
- SI Supply air and extract air silencers

Condensate pump

- without
- KP Condensate pump

RP - 6 - P - RX / ST . -- / V0 . D1 . LU / AF . SI / - . KP . -- . SD / TC . EM . -- . --

Socket

- without
- SD Socket in the unit
- CH Socket in the unit Switzerland

Control system

- TC TopTronic® C

Energy monitoring

- without
- EM Energy monitoring

Table 5: Type code

5 Technical data

5.1 Application limits

| | | | | |
|--|---------|------|-------------------|------|
| Heating mode | | | | |
| Fresh air temperature (WB) | min. | °C | -25 | |
| | max. | °C | 18 | |
| Air inlet temperature to the heating/cooling coil (DB) | min. | °C | 5 | |
| | max. | °C | 24 | |
| Cooling mode | | | | |
| Fresh air temperature (DB) | min. | °C | -10 | |
| | max. | °C | 48 | |
| Air inlet temperature to the heating/cooling coil (WB) | min. | °C | 14 | |
| | max. | °C | 26 | |
| Extract air temperature | | max. | °C | 50 |
| Moisture content of extract air ¹⁾ | | max. | g/kg | 15 |
| Supply air temperature | | max. | °C | 45 |
| Room temperature setpoint | | min. | °C | 12 |
| | | max. | °C | 26 |
| Air flow rate | Size 6: | min. | m ³ /h | 3100 |
| | Size 9: | min. | m ³ /h | 5000 |
| Condensate quantity | Size 6: | max. | kg/h | 90 |
| | Size 9: | max. | kg/h | 150 |
| The units cannot be used in: | | | | |
| ■ Damp locations | | | | |
| ■ Rooms with mineral oil vapours in the air | | | | |
| ■ Rooms with a high salt content in the air | | | | |
| ■ Rooms with acidic or alkaline vapours in the air | | | | |
| 1) Units for applications where the humidity in the room increases by more than 2 g/kg are available on request. | | | | |

Table 6: Application limits

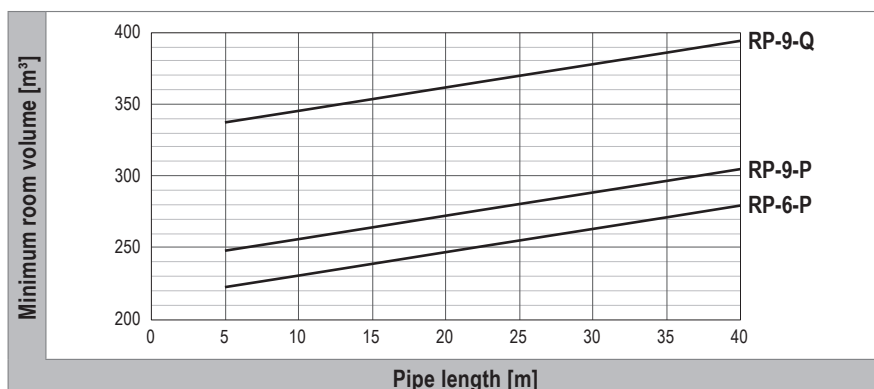

Fig. 3: Minimum room volume depending on the total refrigerant charge in accordance with EN 378

According to EN 378 (Refrigerating systems and heat pumps - Safety and environmental requirements), no additional safety measures for risk reduction are required for Hoval indoor climate units with heat pumps under the following conditions:

- The conditions according to EN 378 Annex C 3.1 are fulfilled.
- The room volume corresponds to the minimum values shown in Fig. 3 meaning that the permissible QLMV value is not exceeded.

5.2 Electrical connection

RoofVent® RP

| Unit type | | RP-6 | RP-9 |
|-----------------------------|------|---------|---------|
| Supply voltage | V AC | 3 × 400 | 3 × 400 |
| Permitted voltage tolerance | % | ± 5 | ± 5 |
| Frequency | Hz | 50 | 50 |
| Connected load | kW | 4.2 | 8.2 |
| Current consumption max. | A | 7.1 | 13.6 |
| Series fuse | A | 13.0 | 20.0 |

Table 7: RoofVent® RP electrical connections

Heat pump

| Heat pump | | P | Q |
|-----------------------------|------|---------|----------|
| Supply voltage | V AC | 3 × 400 | 3 × 400 |
| Permitted voltage tolerance | % | ± 2 | ± 2 |
| Frequency | Hz | 50 | 50 |
| Connected load | kW | 16.8 | 2 × 15.9 |
| Current consumption max. | A | 26.9 | 2 × 25.5 |
| Series fuse | A | 32.0 | 2 × 32.0 |
| Inrush current | A | 5.9 | 2 × 5.9 |

Table 8: Heat pump electrical connections

5.3 Air flow rate

| Unit type | | RP-6 | RP-9 |
|-----------------------|-------------------|------|------|
| Nominal air flow rate | m ³ /h | 5500 | 8000 |
| Floor area covered | m ² | 480 | 797 |

Table 9: Air flow rate

5.4 Air filtration

| Filter | Fresh air | Extract air |
|---|-----------------------|------------------------|
| Class acc. to ISO 16890 | ePM ₁ 55 % | ePM ₁₀ 65 % |
| Class acc. to EN 779 | F7 | M5 |
| Factory setting of differential pressure switches | 250 Pa | 350 Pa |

Table 10: Air filtration

5.5 Heat recovery system (HRS)

| Unit type | | RP-6 | RP-9 |
|-----------------------------|---|------|------|
| Temperature efficiency, dry | % | 77 | 78 |
| Temperature efficiency, wet | % | 89 | 90 |

Table 11: Thermal transfer level of the plate heat exchanger

5.6 Technical data of the heat pump

| Heat pump | | | P | Q |
|--|--------------------------------------|------|---------|-------|
| Heating | Rated heat output ¹⁾ | kW | 39.2 | 67.2 |
| | Power consumption | kW | 8.43 | 15.54 |
| | COP | – | 4.65 | 4.32 |
| | $\eta_{s,h}$ | – | 204 | 197 |
| | SCOP | – | 5.17 | 4.99 |
| Cooling | Rated cooling capacity ²⁾ | kW | 39.2 | 67.2 |
| | Power consumption | kW | 11.88 | 23.30 |
| | EER | – | 3.30 | 2.88 |
| | $\eta_{s,c}$ | – | 339 | 315 |
| | SEER | – | 8.55 | 7.94 |
| Refrigerant | – | R32 | R32 | |
| Refrigerant fill volume | kg | 11.4 | 2 × 8.5 | |
| 1) With fresh air temperature 7 °C / extract air temperature 20 °C | | | | |
| 2) With fresh air temperature 35 °C / extract air temperature 27 °C / 45 % rel. humidity | | | | |

Table 12: Heat pump technical data

5.7 Heat output

| t _F °C | Type RP- | Q kW | Q _{TG} kW | H _{max} m | t _S °C | P _{HP} kW |
|----------------------|-------------|--|-----------------------|-----------------------|----------------------|-----------------------|
| -15 | 6-P | 43.2 | 32.0 | 12.7 | 35.3 | 15.9 |
| | 9-P | 43.2 | 27.9 | 16.7 | 28.3 | 15.9 |
| | 9-Q | 73.8 | 58.5 | 11.8 | 39.7 | 31.0 |
| Legend: | | t _F = Fresh air temperature Q = Heat output Q _{TG} = Output to cover fabric heat losses H _{max} = Maximum mounting height t _S = Supply air temperature P _{HP} = Power consumption of the heat pump | | | | |
| Reference: | | Room air 18 °C, extract air 20 °C / 20 % rel. humidity | | | | |

Table 13: RoofVent® RP heat output

5.8 Cooling capacity

| t _F °C | RH _F % | Type RP- | Q _{sen} kW | Q _{tot} kW | Q _{TG} kW | t _S °C | m _C kg/h | P _{HP} kW |
|----------------------|----------------------|--|------------------------|------------------------|-----------------------|----------------------|------------------------|-----------------------|
| 32 | 40 | 6-P | 27.3 | 42.6 | 21.9 | 14.2 | 22.5 | 12.0 |
| | | 9-P | 27.3 | 42.6 | 19.6 | 18.7 | 22.5 | 12.0 |
| | | 9-Q | 45.9 | 72.3 | 38.1 | 11.8 | 38.8 | 23.4 |
| | 60 | 6-P | 19.3 | 45.6 | 13.9 | 18.5 | 38.6 | 12.7 |
| | | 9-P | 19.3 | 45.6 | 11.5 | 21.7 | 38.7 | 12.7 |
| | | 9-Q | 33.2 | 78.3 | 25.4 | 16.6 | 66.3 | 25.5 |
| Legend: | | t _F = Fresh air temperature RH _F = Relative humidity of the fresh air Q _{sen} = Sensible cooling capacity Q _{tot} = Total cooling capacity Q _{TG} = Output for coverage of transmission sensible gains (→ sensible cooling load) t _S = Supply air temperature m _C = Condensate quantity P _{HP} = Power consumption of the heat pump | | | | | | |
| Reference: | | Room air 26 °C, extract air 28 °C / 50 % rel. humidity | | | | | | |

Table 14: RoofVent® RP cooling capacity

5.9 Sound level

RoofVent® RP

| Position | | | 1 | 2 | 3 | 4 | |
|----------|---|---------|----|----|----|----|----|
| RP-6 | Sound pressure level (at a distance of 5 m) ¹⁾ | dB(A) | 44 | 44 | 52 | 56 | |
| | Total sound power level | dB(A) | 66 | 66 | 74 | 78 | |
| | Octave sound power level | 63 Hz | dB | 44 | 43 | 45 | 46 |
| | | 125 Hz | dB | 54 | 54 | 59 | 61 |
| | | 250 Hz | dB | 60 | 60 | 65 | 67 |
| | | 500 Hz | dB | 62 | 62 | 68 | 71 |
| | | 1000 Hz | dB | 57 | 57 | 71 | 74 |
| | | 2000 Hz | dB | 55 | 55 | 66 | 70 |
| | | 4000 Hz | dB | 51 | 51 | 61 | 66 |
| 8000 Hz | dB | 50 | 49 | 58 | 64 | | |
| RP-9 | Sound pressure level (at a distance of 5 m) ¹⁾ | dB(A) | 43 | 42 | 52 | 55 | |
| | Total sound power level | dB(A) | 65 | 64 | 74 | 77 | |
| | Octave sound power level | 63 Hz | dB | 44 | 42 | 45 | 45 |
| | | 125 Hz | dB | 55 | 54 | 61 | 62 |
| | | 250 Hz | dB | 58 | 57 | 64 | 65 |
| | | 500 Hz | dB | 61 | 59 | 68 | 70 |
| | | 1000 Hz | dB | 58 | 56 | 70 | 73 |
| | | 2000 Hz | dB | 56 | 55 | 67 | 70 |
| | | 4000 Hz | dB | 50 | 48 | 59 | 64 |
| 8000 Hz | dB | 44 | 42 | 54 | 59 | | |

1) With hemispherical radiation in a low-reflection environment

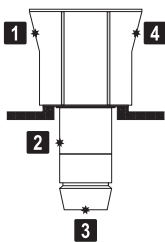

- 1 Fresh air
- 2 Extract air
- 3 Supply air
- 4 Exhaust air

Table 15: RoofVent® RP sound level

Heat pump

| Heat pump | | P | | Q | | |
|---|---------|---------|---------|---------|---------|------|
| | | Heating | Cooling | Heating | Cooling | |
| Sound pressure level (at a distance of 5 m) | dB(A) | 59.0 | 59.0 | 63.0 | 61.0 | |
| Total sound power level ¹⁾ | dB(A) | 81.0 | 81.0 | 85.0 | 83.0 | |
| Octave sound pressure level ²⁾ | 63 Hz | dB | 62.5 | 63.6 | 68.7 | 67.4 |
| | 125 Hz | dB | 58.5 | 58.6 | 62.4 | 59.9 |
| | 250 Hz | dB | 60.1 | 57.7 | 62.2 | 60.8 |
| | 500 Hz | dB | 58.6 | 58.4 | 60.8 | 59.7 |
| | 1000 Hz | dB | 54.3 | 52.2 | 57.6 | 56.4 |
| | 2000 Hz | dB | 51.6 | 49.8 | 54.5 | 53.6 |
| | 4000 Hz | dB | 53.0 | 52.8 | 49.9 | 50.4 |
| | 8000 Hz | dB | 46.7 | 45.9 | 49.2 | 48.2 |

1) The values given are maximum values; the noise level is fluctuating due to scroll technology.
 2) Measured at a distance of 1 m in front of the unit and 1 m above the floor in a semi-anechoic chamber.

Table 16: Heat pump sound level

For particularly quiet unit operation (e.g. during the night), the heat pump can be operated in silent mode. It then runs at a reduced speed of the compressor and/or fan, which also leads to a reduced capacity output depending on the setting parameters.

| Silent mode | Noise reduction | Capacity level | |
|-------------|-----------------|----------------|-------------|
| | | Heat pump P | Heat pump Q |
| Level 1 | - 3 dB | 100 % | 100 % |
| Level 2 | - 6 dB | 95 % | 80 % |
| Level 3 | - 9 dB | 75 % | 55 % |

Table 17: Noise reduction and capacity output in silent mode

5.10 Dimensions and weights

RoofVent® RP-6-P

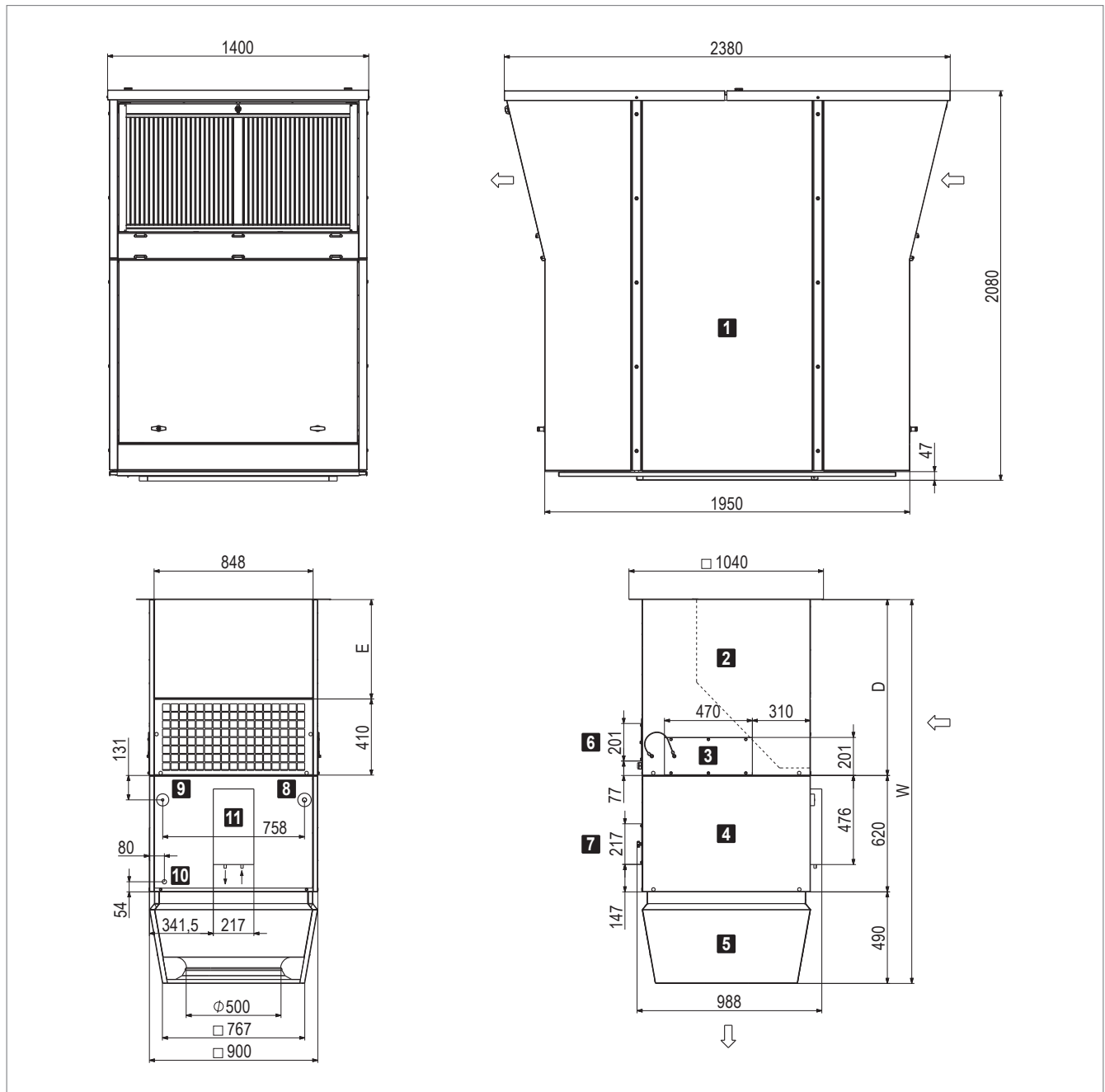

- | | |
|--|---|
| <ul style="list-style-type: none"> 1 Roof unit with energy recovery 2 Connection module 3 Access panel, coil 4 Heating/cooling section 5 Air-Injector 6 Access panel, connection box | <ul style="list-style-type: none"> 7 Access panel, condensate separator 8 Gas line connection (Ø 22 mm) 9 Liquid line connection (Ø 12 mm) 10 Condensate connection (G 1" external) 11 EEV kit P (connection Ø 12.7 mm) |
|--|---|

Fig. 4: RoofVent® RP-6-P dimensions

| Connection module | | V0 | V1 | V2 | V3 |
|-------------------|----|------|------|------|------|
| D | mm | 940 | 1190 | 1440 | 1940 |
| E | mm | 530 | 780 | 1030 | 1530 |
| W | mm | 2050 | 2300 | 2550 | 3050 |

Table 18: RoofVent® RP-6-P dimensions

| Unit type | | RP-6-P |
|-------------------------|-----------|------------|
| Total | kg | 905 |
| Roof unit | kg | 702 |
| Below-roof unit | kg | 203 |
| Air-Injector | kg | 37 |
| Heating/cooling section | kg | 88 |
| Expansion valve | kg | 3 |
| Connection module V0 | kg | 75 |
| Additional weight V1 | kg | + 11 |
| Additional weight V2 | kg | + 22 |
| Additional weight V3 | kg | + 44 |

Table 19: RoofVent® RP-6-P weights

RoofVent® RP-9-P

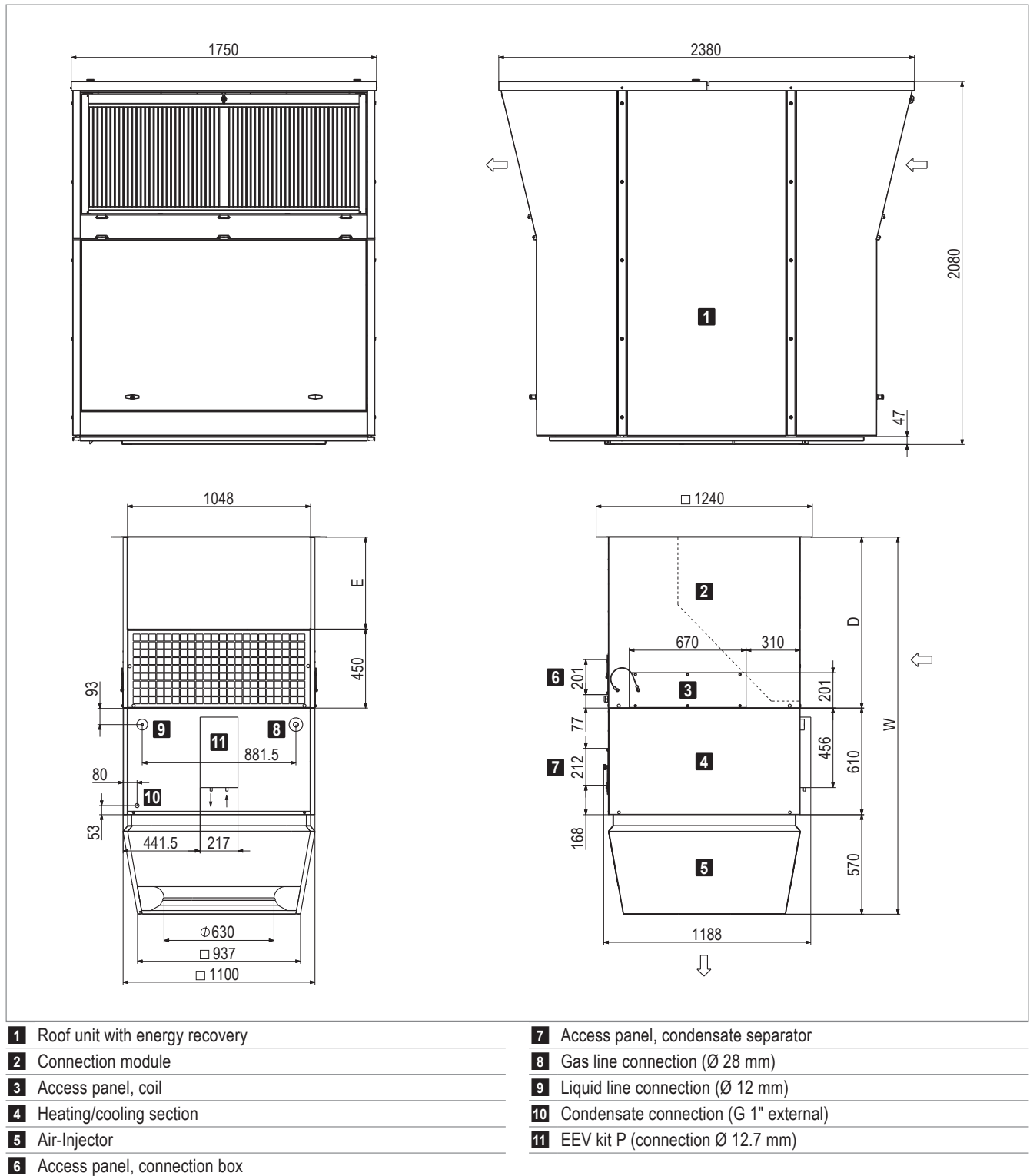

Fig. 5: RoofVent® RP-9-P dimensions

| Connection module | | V0 | V1 | V2 | V3 |
|-------------------|----|------|------|------|------|
| D | mm | 980 | 1230 | 1480 | 1980 |
| E | mm | 530 | 780 | 1030 | 1530 |
| W | mm | 2160 | 2410 | 2660 | 3160 |

Table 20: RoofVent® RP-9-P dimensions

| Unit type | | RP-9-P |
|-------------------------|-----------|-------------|
| Total | kg | 1192 |
| Roof unit | kg | 902 |
| Below-roof unit | kg | 290 |
| Air-Injector | kg | 56 |
| Heating/cooling section | kg | 137 |
| Expansion valve | kg | 3 |
| Connection module V0 | kg | 94 |
| Additional weight V1 | kg | + 13 |
| Additional weight V2 | kg | + 26 |
| Additional weight V3 | kg | + 52 |

Table 21: RoofVent® RP-9-P weights

RoofVent® RP-9-Q

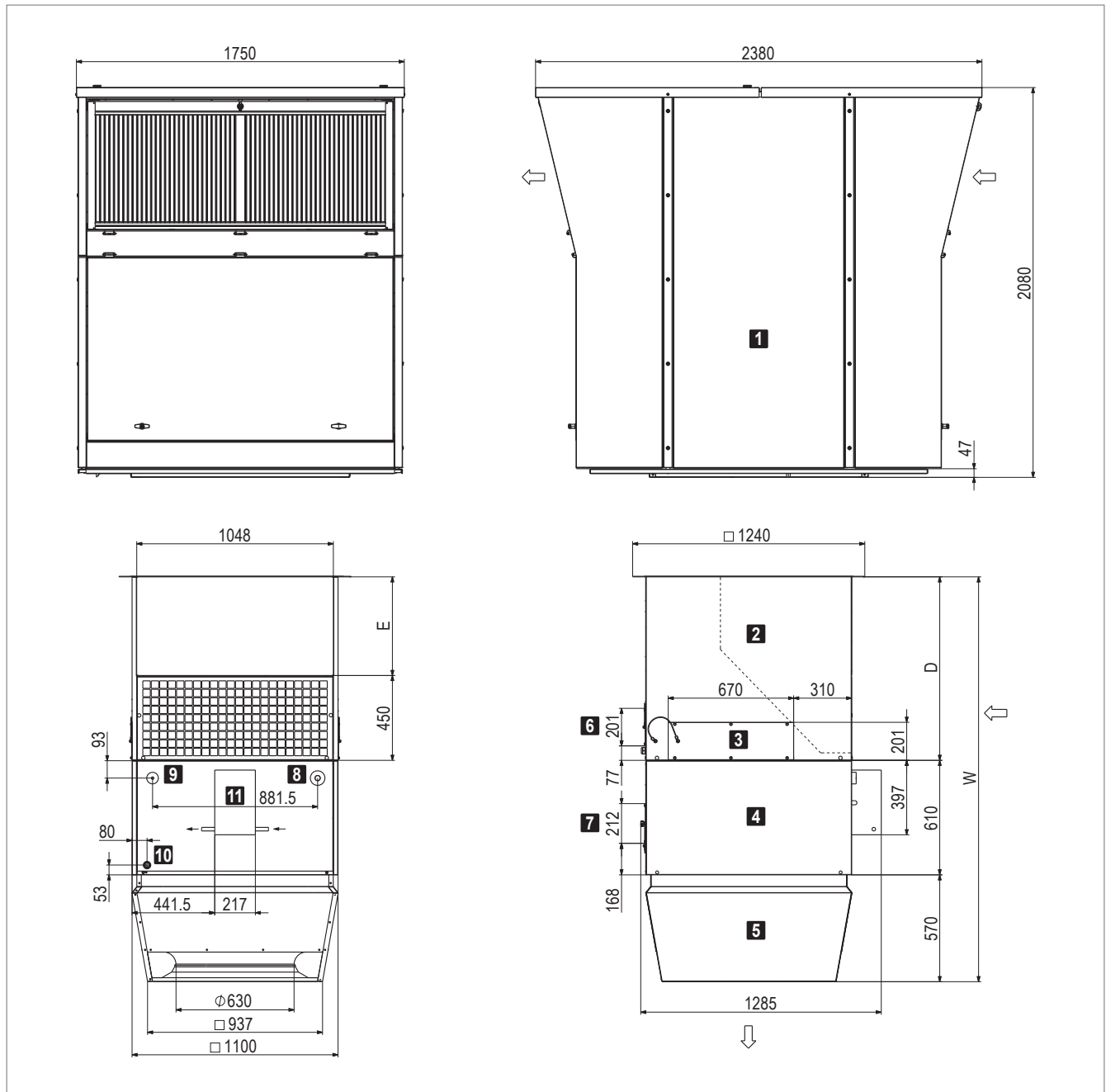

- | | |
|---|--|
| 1 Roof unit with energy recovery | 7 Access panel, condensate separator |
| 2 Connection module | 8 Gas line connection ($\phi 28$ mm) |
| 3 Access panel, coil | 9 Liquid line connection ($\phi 12$ mm) |
| 4 Heating/cooling section | 10 Condensate connection (G 1" external) |
| 5 Air-Injector | 11 EEV-Kit Q (connection $\phi 19.05$ mm) |
| 6 Access panel, connection box | |

Fig. 6: RoofVent® RP-9-Q dimensions

| Connection module | | V0 | V1 | V2 | V3 |
|-------------------|----|------|------|------|------|
| D | mm | 980 | 1230 | 1480 | 1980 |
| E | mm | 530 | 780 | 1030 | 1530 |
| W | mm | 2160 | 2410 | 2660 | 3160 |

Table 22: RoofVent® RP-9-Q dimensions

| Unit type | | RP-9-Q |
|-------------------------|-----------|-------------|
| Total | kg | 1193 |
| Roof unit | kg | 902 |
| Below-roof unit | kg | 291 |
| Air-Injector | kg | 56 |
| Heating/cooling section | kg | 137 |
| Expansion valve | kg | 4 |
| Connection module V0 | kg | 94 |
| Additional weight V1 | kg | + 13 |
| Additional weight V2 | kg | + 26 |
| Additional weight V3 | kg | + 52 |

Table 23: RoofVent® RP-9-Q weights

Heat pump P

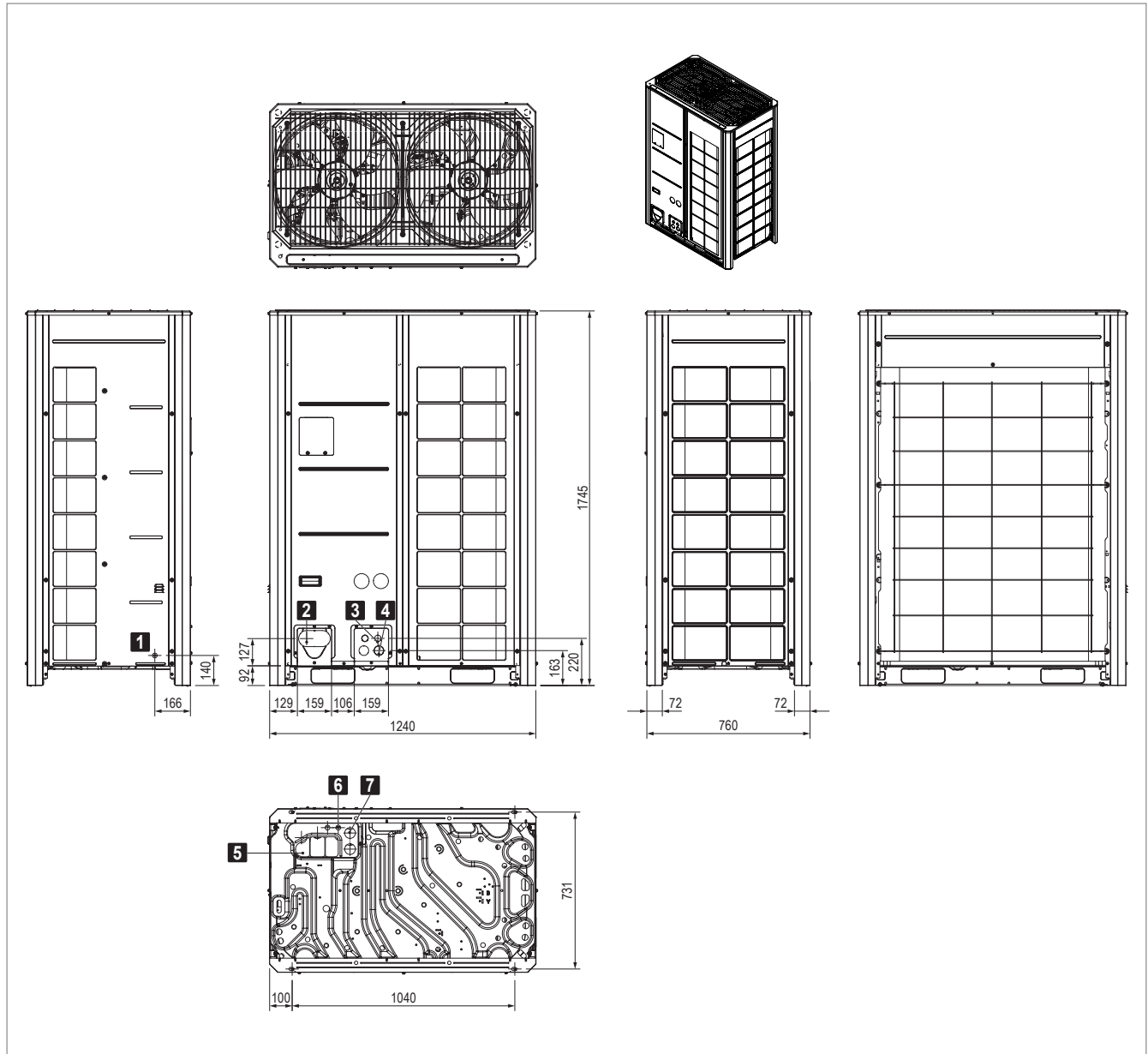

- 1** Opening for leak-tightness test
- 2** Opening for refrigerant pipes (front)
 - Liquid line connection Ø 12.7 mm
 - Gas line connection Ø 22.2 mm
- 3** Opening for signal lines (front)
- 4** Opening for mains cable (front)
- 5** Opening for refrigerant pipes (bottom)
- 6** Opening for signal lines (bottom)
- 7** Opening for mains cable (bottom)

| Heat pump | | P |
|-----------|----|-----|
| Weight | kg | 255 |

Fig. 7: Heat pump P dimensions and weights

Heat pump Q

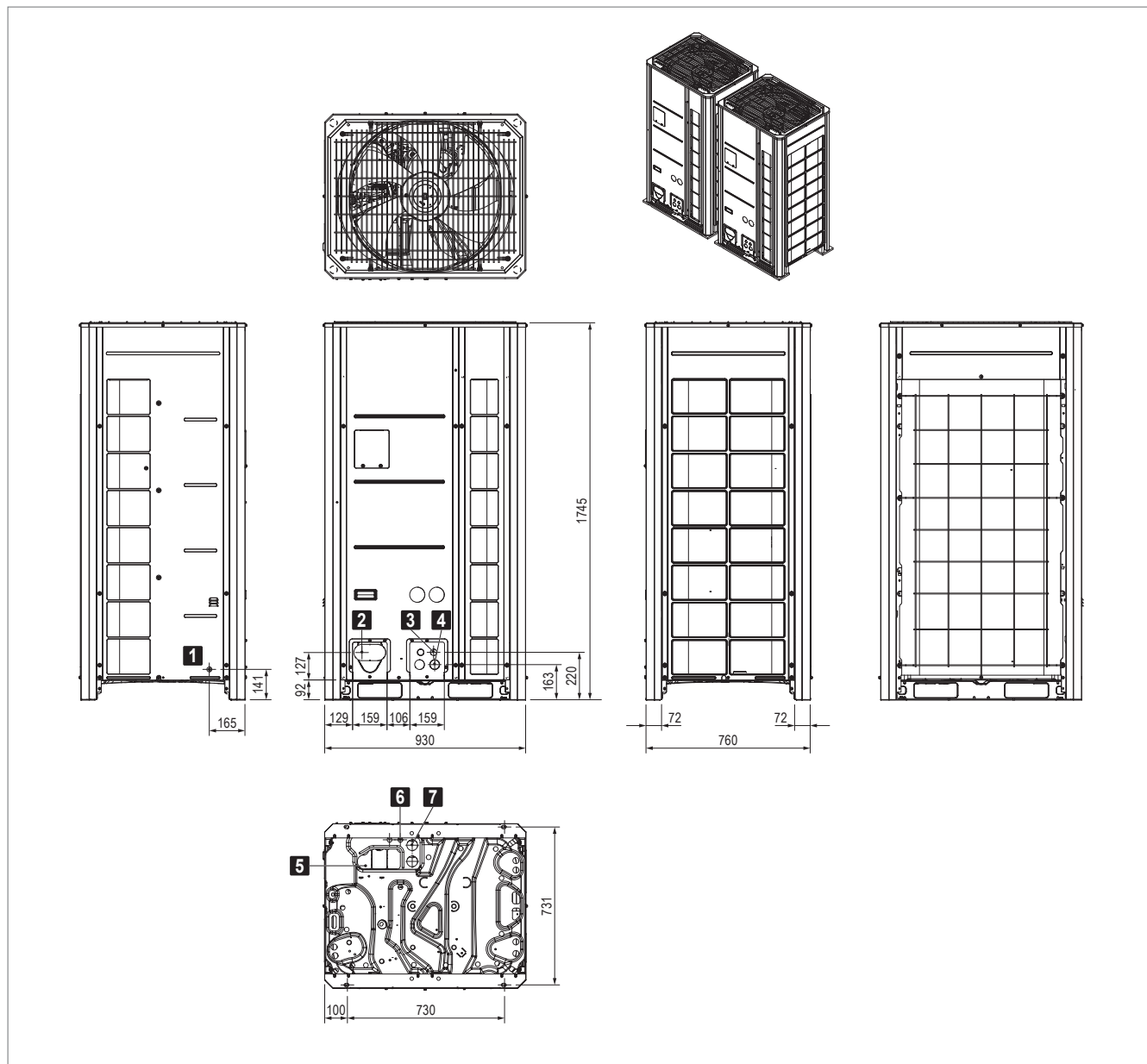

- 1** Opening for leak-tightness test

- 2** Opening for refrigerant pipes (front)
 - Liquid line connection Ø 12.7 mm
 - Gas line connection Ø 22.2 mm

- 3** Opening for signal lines (front)

- 4** Opening for mains cable (front)

- 5** Opening for refrigerant pipes (bottom)

- 6** Opening for signal lines (bottom)

- 7** Opening for mains cable (bottom)

| Heat pump | | Q |
|-----------|----|---------|
| Weight | kg | 2 × 215 |

Fig. 8: Heat pump Q dimensions and weights

6 Options

6.1 Connection module

The connection module is available in 4 lengths for adapting the RoofVent® unit to local conditions.

6.2 Design with 2 Air-Injectors

To distribute the supply air over a very wide area, a supply air duct can be connected to the RoofVent® unit. 2 Air-Injectors can be installed on this. The supply air duct and the cabling must be provided by the client.

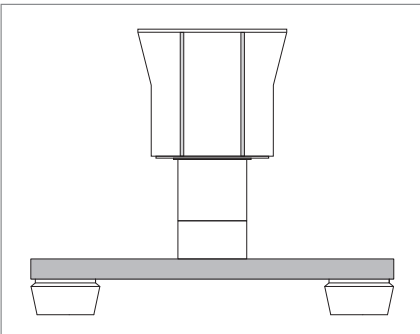

Fig. 9: RoofVent® unit with supply air duct and 2 Air-Injectors

6.3 Design without Air-Injector

RoofVent® units in the design without Air-Injector are suitable for connecting to an air distribution system supplied by the client.

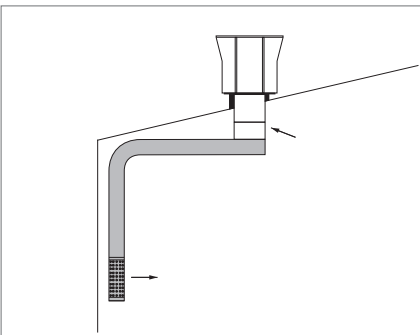

Fig. 10: Connection to an air distribution system supplied by the client

6.4 Paint finish of below-roof unit

The entire below-roof unit including optional components is painted in any colour.

6.5 Fresh air and exhaust air silencers

The fresh air silencer reduces noise emissions from RoofVent® units on the fresh air side. It consists of an aluminium casing with a bird screen and acoustic insulation lining and is configured as an add-on part for the roof unit which can be folded downwards.

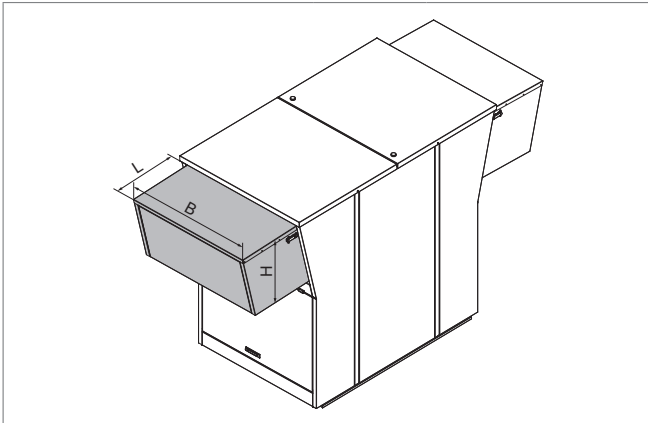

| Size | | 6 | 9 |
|---------------|----|------|------|
| L | mm | 625 | 625 |
| B | mm | 1280 | 1630 |
| H | mm | 650 | 650 |
| Weight | kg | 30 | 42 |
| Pressure drop | Pa | 10 | 10 |

Table 24: Technical data fresh air silencer

The exhaust air silencer reduces noise emissions from RoofVent® units on the exhaust air side. It consists of an aluminium casing with a bird screen and sound attenuation splitters and is configured as an add-on part for the roof unit which can be folded downwards.

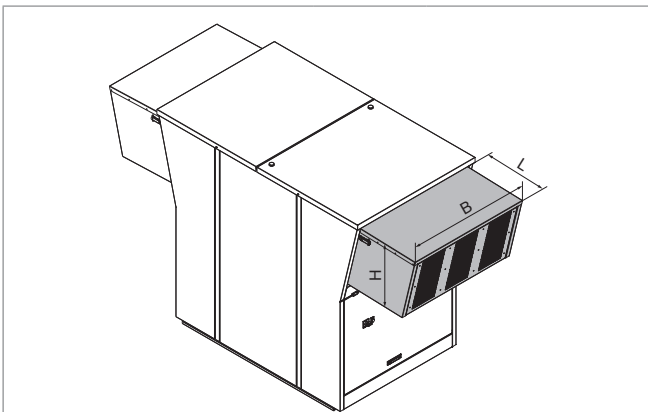

| Size | | 6 | 9 |
|---------------|----|------|------|
| L | mm | 625 | 625 |
| B | mm | 1280 | 1630 |
| H | mm | 650 | 650 |
| Weight | kg | 52 | 68 |
| Pressure drop | Pa | 50 | 53 |

Table 25: Technical data exhaust air silencer

6.6 Supply air and extract air silencers

Supply air and extract air silencers reduce the noise from RoofVent® units within the room. The supply air silencer is designed as a separated component and is installed above the Air-Injector. The extract air silencer consists of acoustic insulation lining in the connection module.

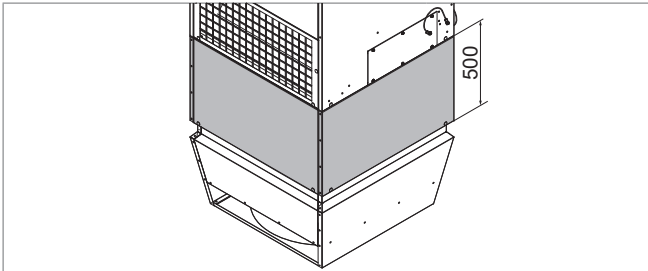

| Size | | 6 | 9 |
|---------------------------|----|----|----|
| Weight | kg | 53 | 80 |
| Supply air pressure drop | Pa | 22 | 26 |
| Extract air pressure drop | Pa | 0 | 0 |

Table 26: Technical data supply air and extract air silencers

6.7 Condensate pump

The condensate pump is installed directly under the condensate drain connection; the supplied container is prepared for installation on the unit. It pumps the condensate through a flexible hose to a delivery head of 3 m, thus enabling discharge of the condensate

- through waste water pipes directly below the ceiling,
- onto the roof.

6.8 Socket

For maintenance work, a socket (1-phase, 230 V AC, 50 Hz) can be installed in the roof unit, next to the control block.

6.9 Energy monitoring

Energy monitoring makes it possible to display the energy saved by heat and cool recovery. For this purpose, 2 additional temperature sensors are installed in the RoofVent® units; they record the air inlet and air outlet temperatures of the plate heat exchanger.

7 Transport and installation



Caution

Risk of injury from incorrect handling. Transport, assembly and installation work may only be performed by specialists. Observe safety and accident prevention regulations.

7.1 Delivery

The scope of delivery includes:

- RoofVent® RP unit, delivered as standard in 2 parts on pallets (roof unit, below-roof unit)
- Heat pump
- Accessories
- Optional components
- Zone control panel

Associated parts are labelled with the same unit number and serial number. Depending on the unit size, the below-roof unit can also be delivered in multiple parts.

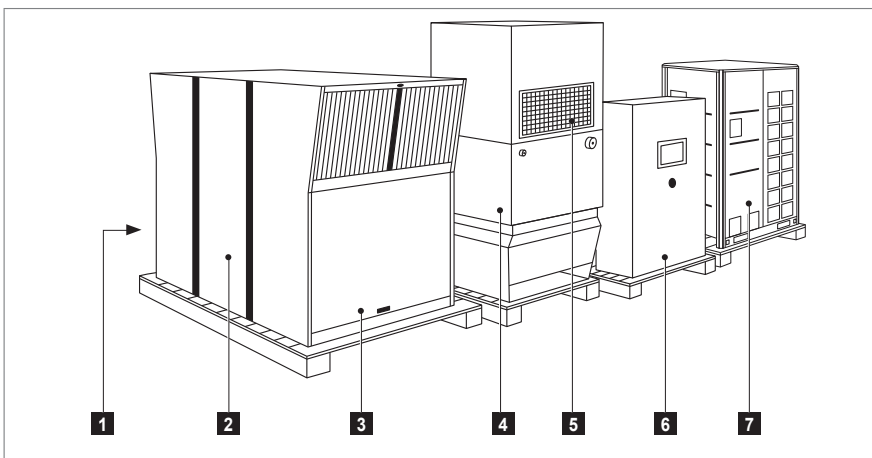

- | | |
|---|------------------------------|
| 1 | Supply air access door |
| 2 | RoofVent® RP roof unit |
| 3 | Extract air access door |
| 4 | RoofVent® RP below-roof unit |
| 5 | Extract air grille |
| 6 | Zone control panel |
| 7 | Heat pump |

Fig. 11: Delivery of the components on pallets

Accessories

The following accessories are supplied separately:

- Transport eyes for lifting the below-roof unit and the roof unit (2 each, attached to the pallet of the first roof unit)
- Screws for assembling the units and for fixing the fan protecting plate (attached to the pallet of the roof unit)
- If the below-roof unit is delivered in multiple parts: Screws for assembling the below-roof unit (behind the extract air grille)
- Extract air filter (behind the extract air access door)
- PG screw joint for electrical connection (behind the connection box access panel; this is located in the below-roof unit opposite the extract air grille)
- Trap (behind the extract air grille)
- Electrical diagram and 2 keys for the access doors (behind the supply air access door)
- Fresh air temperature sensor and room temperature sensor (in the zone control panel)
- Liquid temperature sensor and gas temperature sensor (inside the communication kit)

- EEV kit (behind the extract air grille)
- For units with heat pump Q:
 - Branch joint kit Q (behind the extract air grille)

Options

The following optional components are supplied separately:

- Fresh air and exhaust air silencer (on separate pallet; bolts, hinges and screws enclosed)
- Condensate pump (behind the extract air grille)
- Additional room temperature sensors, combination sensor room air quality, temperature and humidity (in zone control panel)
- Version with 2 Air-Injectors or without Air-Injector: A supply air temperature sensor is enclosed behind the extract air grille.

Preparation

- The units are delivered screwed onto the pallet. To loosen the screws, the inspection doors must be opened. When unloading the units, make sure that there is enough space to open the inspection doors.
- Use a forklift with a sufficiently long fork to unload (at least 1.8 m).
- Check the consignment against the delivery documents and the order confirmation to ensure that it is complete. Report missing parts and any damage immediately in writing.

Heat pump

- Lifting the heat pump with a crane:
 - Lift the unit at 4 suspension points.
 - Use 2 straps at least 8 m in length.
 - Pass the straps through the openings at the bottom of the unit.
 - Use cloths or boards to protect the points where the unit comes into contact with the straps.
- Lifting the heat pump with a forklift:
 - Transport to the installation site: Lift the unit under the pallet.
 - Unloading from the pallet: Guide the forklift tines into the large rectangular openings under the device.

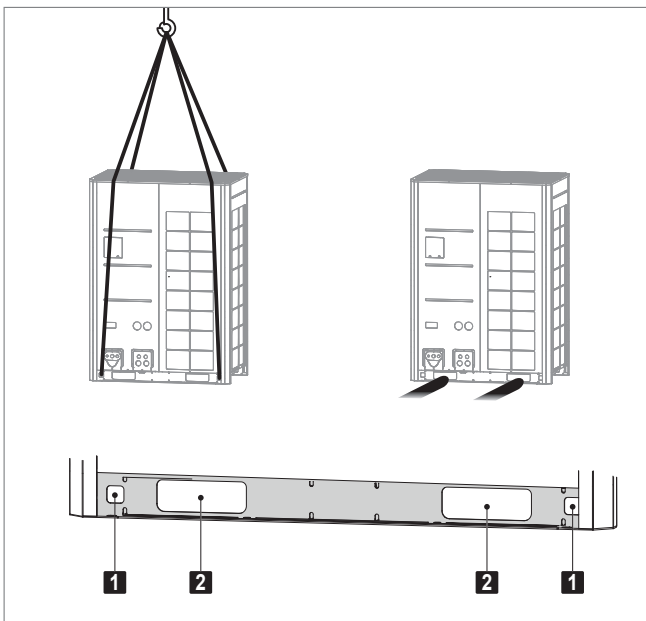

1 Openings for straps

2 Openings for forklift

Fig. 12: Lifting the heat pump

7.2 Storage

If you do not install the unit immediately:

- Remove the packaging film to avoid water vapour condensation.
- Store the unit in a dry, dust-free room.
- Keep the storage temperature between -30 °C and $+50\text{ °C}$.
- Avoid too long storage periods. After a storage period of more than 1 year:
 - Check that the bearings of the fans move smoothly before installing the unit.

7.3 Requirements for the installation site

RoofVent® unit

- Make sure that the roof has sufficient load-bearing capacity and that the roof frames correspond to the specifications in the design handbook.
- Position the units according to the system layout. In doing so, ensure that the units are aligned to one another, the minimum and maximum distances are observed and that the correct coil connections are correctly positioned. Units must not draw in exhaust air from other units as fresh air.
- All air inlet and air outlet openings must be freely accessible. The supply air jet must be free to spread out unhindered.
- The access doors in the roof unit and the access panels in the below-roof unit must be easily accessible.
- Clearance of at least 0.9 m is required for maintenance work around the heating/cooling section.

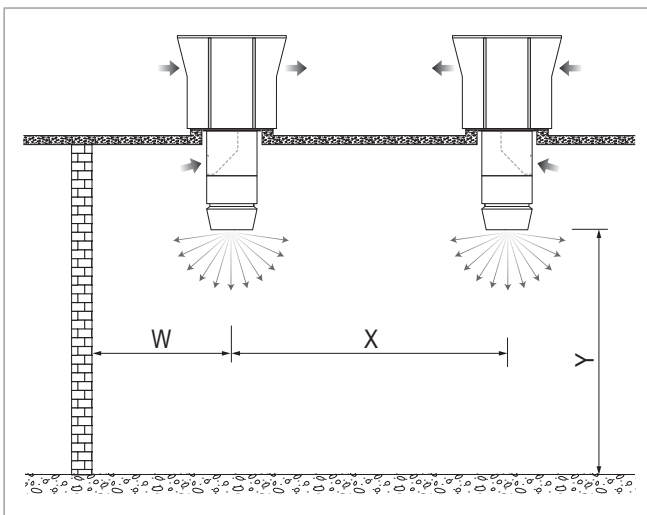

| Size | | | 6 | 9 |
|----------------------|--------------------|---|----------------|----|
| Distance from wall W | max. | m | 11 | 14 |
| | min. | m | 6 | 7 |
| Unit clearance X | max. | m | 22 | 28 |
| | min. | m | 11 | 13 |
| Mounting height Y | max. ¹⁾ | m | Approx. 9...25 | |
| | min. | m | 4 | 5 |

1) The maximum mounting height varies depending on the boundary conditions (for values, see table of heat outputs or calculation with the «HK-Select» selection program)

Table 27: Minimum and maximum distances

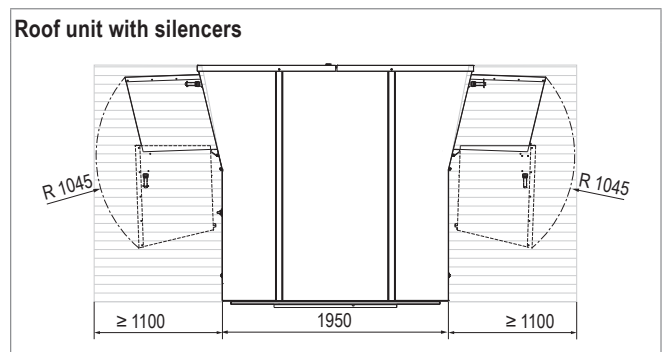
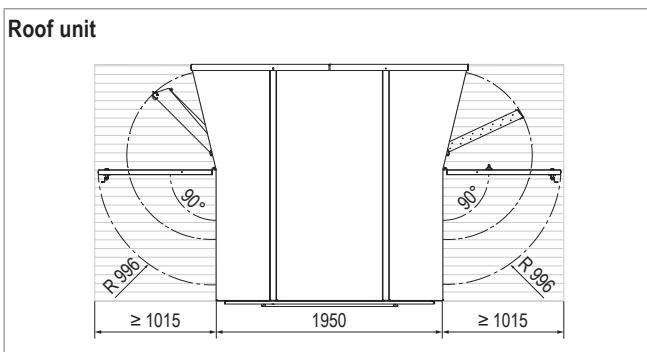

Fig. 13: Space requirements for maintenance on the roof (dimensions in mm)



Notice

If side access is not possible, proportionally more space is required for opening the access doors.

Heat pump

- Place the heat pump as close as possible to the indoor climate unit, in a well ventilated location.



Notice

Excessively long refrigerant lines reduce the efficiency of the system. Place the heat pump as close as possible to the indoor climate unit.

- Note the following when choosing a location:
 - Not in potentially explosive atmospheres
 - Not in the vicinity of machines emitting electromagnetic waves
 - Not in locations where there is a fire hazard due to the escape of flammable gases
 - Not near a heat source with high temperature
 - Not in locations where dust or dirt can affect the heat exchangers
 - Not in locations with mineral oil vapours in the air
 - Not in locations with acidic or alkaline vapours in the air
 - Not in locations with a high salt content in the air



Caution

Risk of damage to health. Corrosion of refrigerant pipes causes leaks and refrigerant can escape.

- Heat pump Q: Place the two single units as close to each other as possible.
 - The maximum length of the refrigerant pipes between the two single units is 10 m.

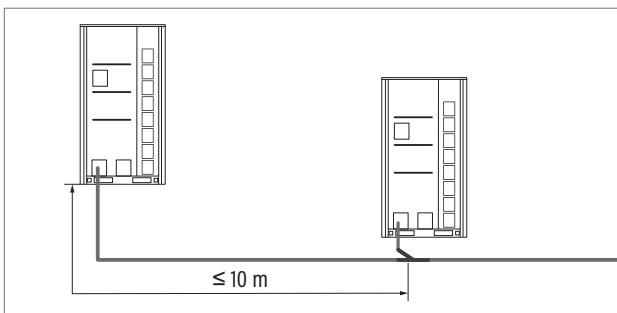

Fig. 14: Maximum length of the refrigerant pipes

- Observe the minimum distances for sufficient air flow through the heat pump.
- Place the heat pump on a solid base with sufficient load-bearing capacity to avoid vibrations and noise.

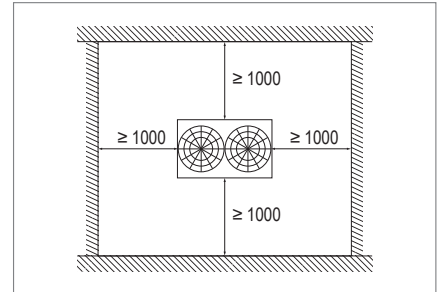

Fig. 15: Minimum distances for the heat pump P (dimensions in mm)

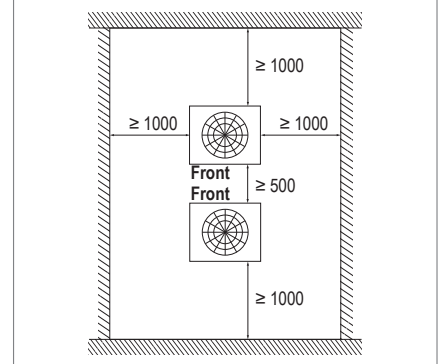
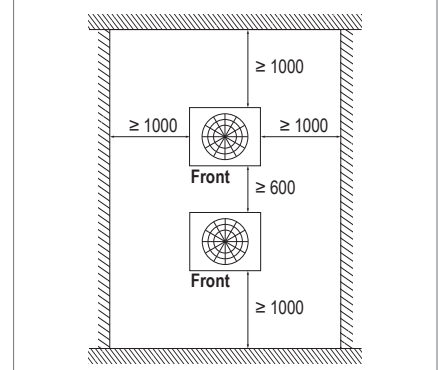
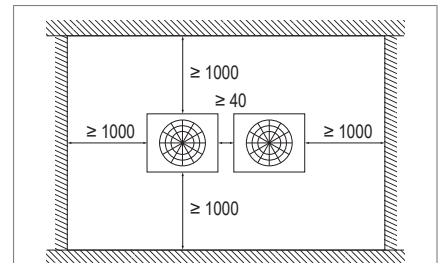

Fig. 16: Minimum distances for the heat pump Q (dimensions in mm)

- Install the heat pump on a solid base or on support blocks made of concrete or steel:
 - The base must be at least 200 mm high to allow sufficient space for the installation of the refrigerant pipes.
 - The support blocks must be at least 100 mm wide and they must also support the unit in the centre.
 - The supporting surface must be flat and level (max. inclination $\pm 0.2\%$). The support points must bear the weight evenly.
 - Water must be free to drain through the base plate of the heat pump.
- Align the heat pump in such a way that the front faces the prevailing wind direction.
- In areas with heavy snowfall:
 - Increase the base height to ensure that the unit operation is not affected by snow.
 - Remove the rear grille from the unit to prevent snow accumulation.

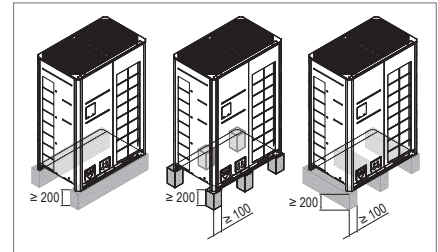

Fig. 17: Base for the heat pump

7.4 Installing the heat pump



Caution

Risk of injury caused by falling load and improper handling.

During installation:

- Wear personal protective equipment.
- Do not stand under suspended loads.
- Use cranes or forklifts with sufficient load-bearing capacity.

- Transport the heat pump to the installation site.
- Drill holes for the anchor bolts in the prepared base (dimensions see Table 28).
- Mount the heat pump on the base using vibration dampers and 4 anchor bolts $\varnothing 10$ mm.

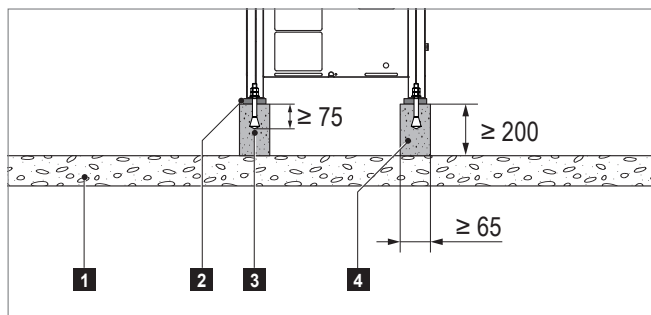

- 1** Firm ground
- 2** Vibration damper
- 3** Anchor bolt $\varnothing 10$ mm
- 4** Base made of concrete or steel

Fig. 18: Installing the heat pump

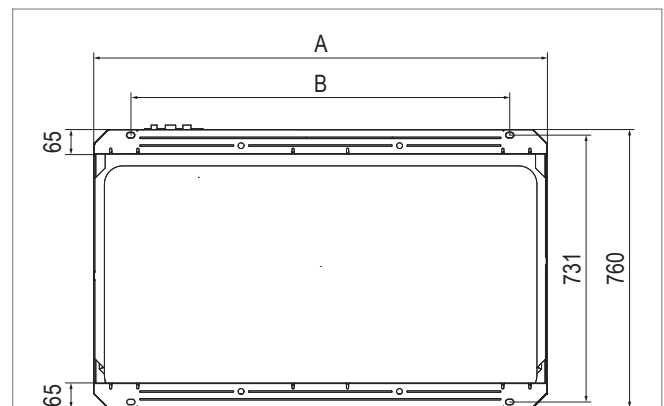

| Heat pump | P | Q (2 single units) |
|-----------|------|--------------------|
| A | 1240 | 930 |
| B | 1040 | 730 |

Table 28: Position of the screw connections (dimensions in mm)

7.5 Installing the RoofVent® RP unit



Caution

Risk of injury caused by falling load and improper handling.

During installation:

- Wear personal protective equipment.
- Do not stand under suspended loads.
- Use cranes or forklifts with sufficient load-bearing capacity.



Caution

Provide suitable protective devices and make sure the units can be accessed easily. The maximum roof load of the RoofVent® units is 80 kg.

Preparation

- The units are assembled from roof level. Make sure that the following items are on hand for the assembly:
 - Crane for installing the below-roof unit
 - Crane or helicopter for assembly on the roof
 - Ladder for screwing in the transport eyes
 - Lifting gear (minimum length of the lifting ropes: 2 m for the below-roof unit, 3 m for the roof unit)
 - Sealing compound for the roof frame (e.g. Sikaflex® 221)
 - Adhesive for securing screws (e.g. Loctite® 243, medium strength, soluble)
- Below-roof unit:
 - Remove the below-roof unit from the packaging film.
 - Remove the mounting bracket or wooden slats with which the below-roof unit is fixed to the pallet.
- Roof unit:
 - Remove the roof unit from the packaging film.
 - Open the extract air access door.
 - Behind this, loosen what is fixing the unit to pallet (2 screws).
 - Open the supply air access door.
 - Unscrew the fan protecting plate; this is only reattached when the unit is installed on the roof.
 - Behind the fan protecting plate, loosen what is fixing the unit to the pallet (2 screws).

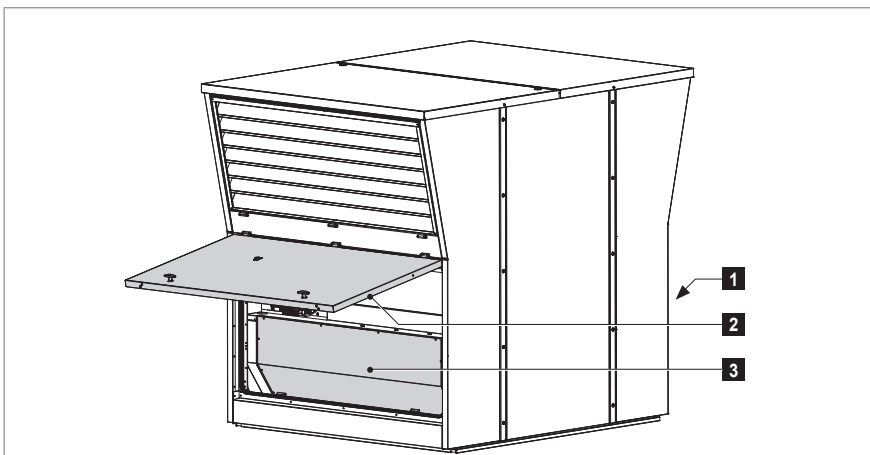

1 Extract air access door

2 Supply air access door

3 Fan protecting plate

Fig. 19: The fan protecting plate is temporarily attached with 4 screws during delivery.

Assembling the below-roof unit

The below-roof unit must only be assembled at the building site if it must be delivered in multiple parts due to the unit version. Proceed as follows:

- Make sure that the correct unit components match up (observe the unit number and RoofVent® serial number).
- Screw in the transport eyes into the connection module frame and attach the lifting gear.
- Lift the connection module complete with mounted components and rotate it into the correct position.
 - The standard position of the refrigerant connections is underneath the extract air grille. If another orientation is required, you can mount the heating/cooling section turned round on the connection module.



Notice

Never change the orientation of the supply air silencer (option) relating to the component above it. The correct position is marked on the unit.

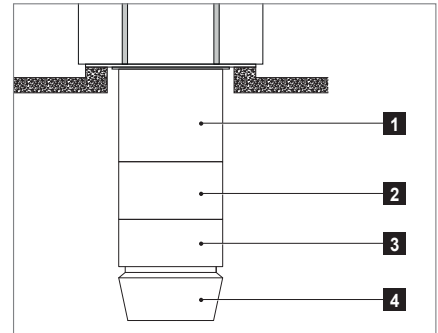

- 1** Connection module
- 2** Heating/cooling section
- 3** Supply air silencer (option)
- 4** Air-Injector

Fig. 20: Components of the below-roof unit

- Place the connection module on the bottom part.
- Screw the components together; use the supplied screws and protective plugs to do so.

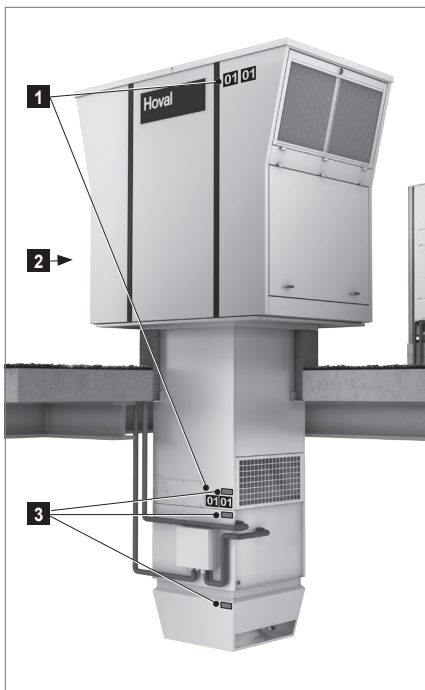

- 1** Unit number
- 2** Type plate with serial number (behind the access door)
- 3** Serial number

Fig. 23: Identification of the unit components



Fig. 21: Transport eye

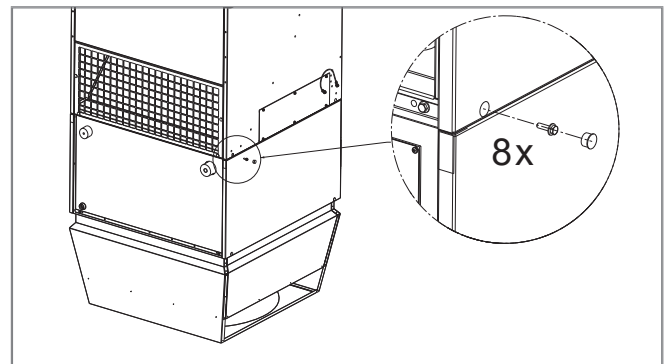

Fig. 22: Below-roof unit screw connection with M6 x 20 screws and protective plugs (8 per component)

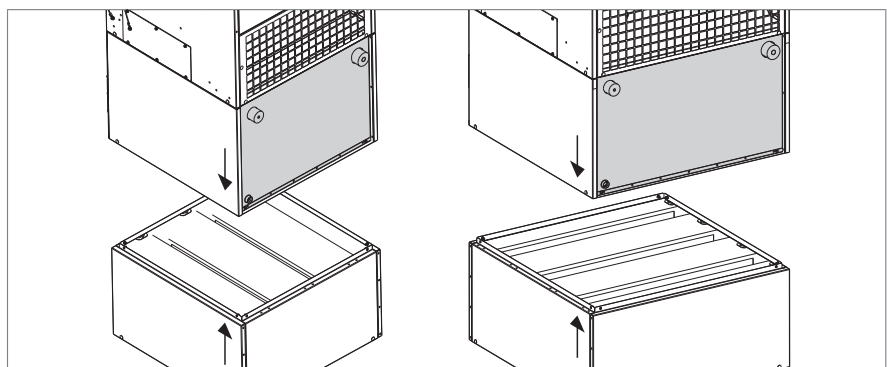
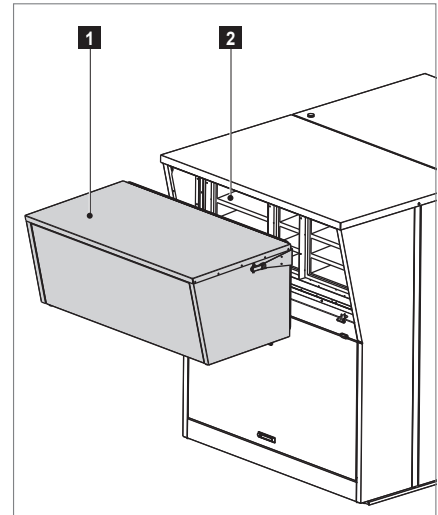

Fig. 24: Correct orientation of the supply air silencer:
For size 6: Sound attenuation splitters cross to refrigerant connection side
For size 9: Sound attenuation splitters parallel to refrigerant connection side

Installing fresh air and exhaust air silencers

Fresh air and exhaust air silencers (optional) are supplied separately and must be installed on the roof unit at the building site. The mounting material is provided. Proceed as follows:

- Fresh air silencer
 - Lift the silencer and position it on the air inlet opening of the unit.
 - Insert the bolts into the hinges and insert the safety washers.
 - Fold the silencer up and hook the clamping lock in on both sides.
 - Secure the clamping locks with cotter pins.
- Exhaust air silencer
 - Lift the silencer and position it on the air outlet opening of the unit.
 - Insert the bolts into the hinges and insert the safety washers.
 - Fold the silencer up and hook the clamping lock in on both sides.
 - Secure the clamping locks with screws.



1 Fresh air silencer
2 Fresh air filter

Fig. 26: Air inlet opening

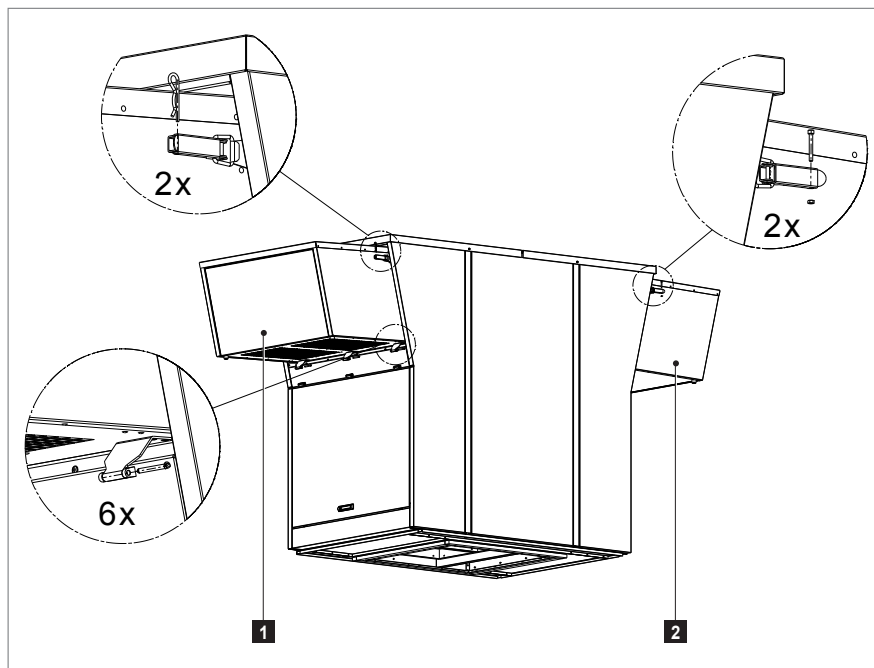

1 Fresh air silencer
2 Exhaust air silencer

Fig. 25: Installing fresh air and exhaust air silencers

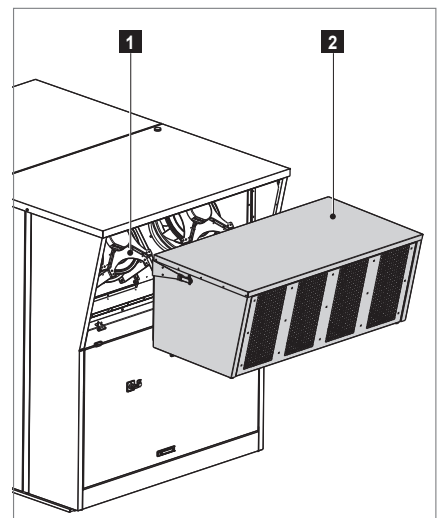

1 Exhaust air fan
2 Exhaust air silencer

Fig. 27: Air outlet opening

Installing the below-roof unit

- Apply sealing compound to the roof frame.
- Screw in the transport eyes into the connection module frame and attach the lifting gear.
 - Heed the minimum length of the lifting ropes (see Fig. 28).
- Transport the below-roof unit to the roof frame using a helicopter or crane.
- Turn the below-roof unit to the desired position.
- Hang the below-roof unit into the roof frame from above.
- Check the sealing strip on the connection module flange. Improve the seal if necessary.
- Remove the transport eyes.

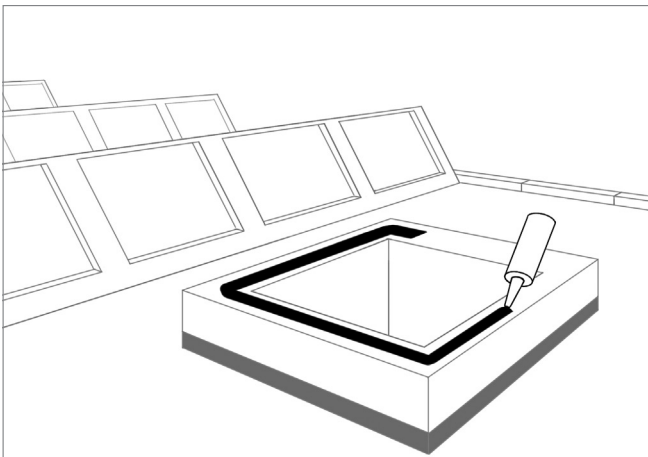

Fig. 29: Applying sealing compound to the roof frame

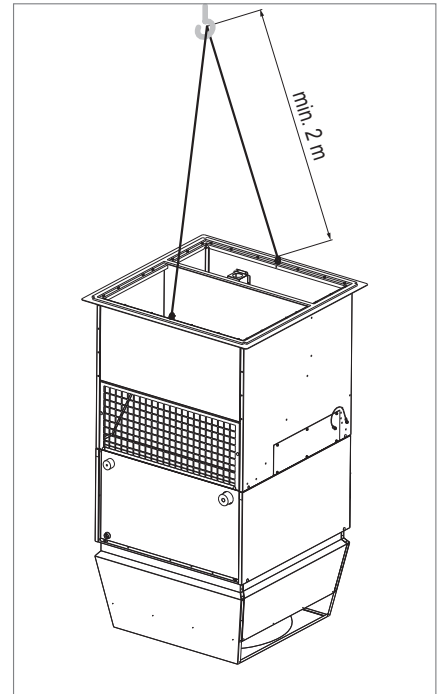

Fig. 28: Minimum length of the lifting ropes

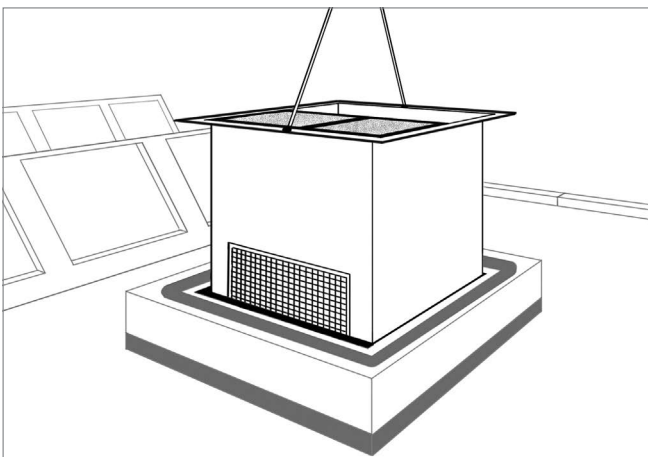

Fig. 30: Hanging the below-roof unit

Installing the roof unit

- Remove the cover caps on the unit roof.
- Screw in the transport eyes and attach the lifting gear.
 - Heed the minimum length of the lifting ropes (see Fig. 31).
- Transport the roof unit onto the roof.
- Open the supply air access door and the exhaust air access door and position the roof unit correctly in relation to the below-roof unit, placing the roof unit on top of the below-roof unit. The centring bolts on the connection module support the correct positioning.
- Screw the roof unit to the below-roof unit:
 - To do this, use the supplied M6 x 30 screws.
 - Secure the screw connection using medium-strength, soluble adhesive (e.g. Loctite® 243).
- Remove the transport eyes and attach the cover caps.
 - Keep the transport eyes for when disassembling the units at a later date at the end of their service life.
- Reattach the fan protecting plate on the supply air side:
 - Temporarily screw the protecting plate tight using 4 M5 x 16 screws; it must be removed again for electrical installation later.



Attention

Risk of damage to the unit due to condensation. If the electrical installation is not carried out until the next day or later and cold weather is to be expected: Tighten the fan protecting plate with all screws to prevent condensation.

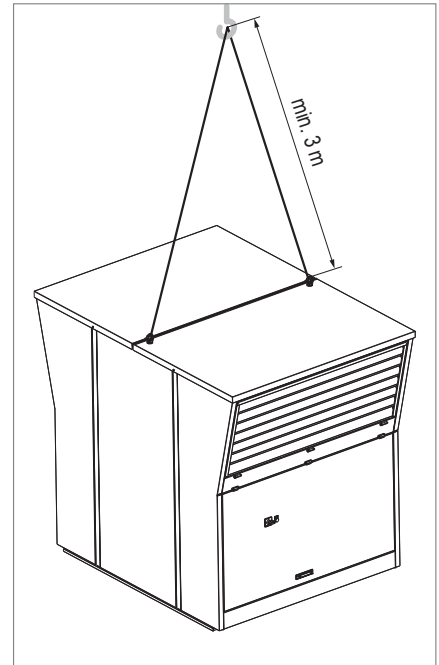
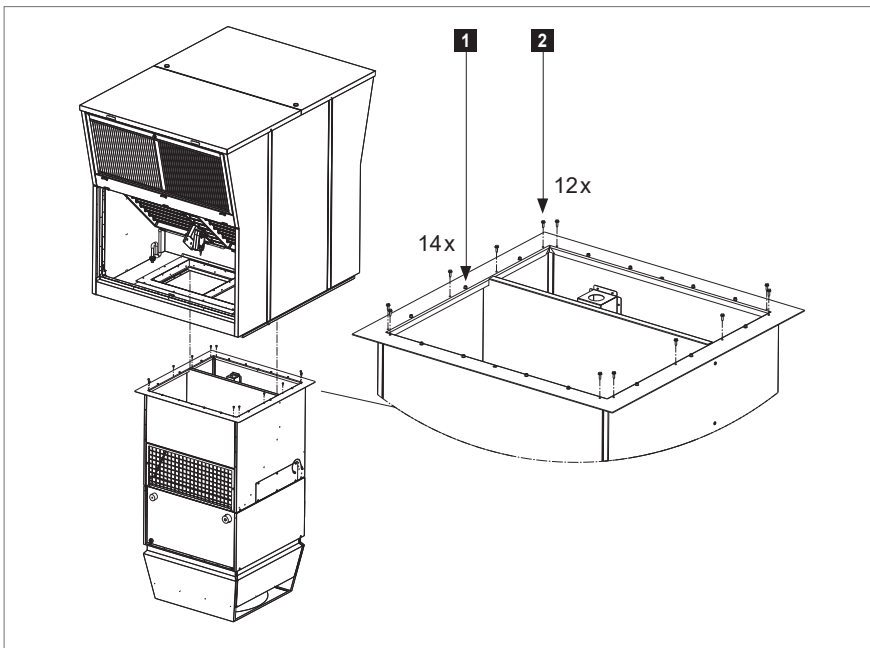

Fig. 31: Minimum length of the lifting ropes



- 1 Centring bolts
- 2 M6 x 30 screws

Fig. 32: Placing and screwing the roof unit

- Install the extract air filter and attach the elements using the filter brackets.



Caution

Danger of hazardous emissions from damaging the filters:

- Only hold the compact filters on the black filter frame.
- Never touch the white filter medium.
- Replace damaged filter elements immediately.



Fig. 33: Extract air filter installed in the unit

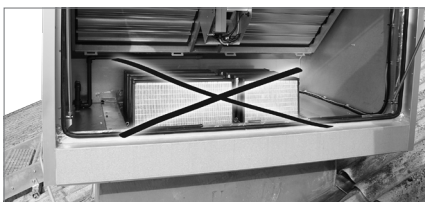

Fig. 34: Incorrect extract air filter position

Installing the EEV kit

After mounting the RoofVent® unit in the roof:

- Screw the EEV kit to the below-roof unit as shown in Fig. 35.



Attention

Risk of malfunctions due to incorrect installation position: It is essential that the expansion valve is installed in a vertical position with the connection pipes at the bottom.

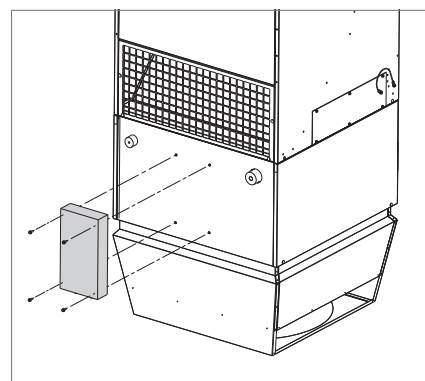

Fig. 35: Installing the EEV kit

7.6 Connecting air ducts and Air-Injectors



Attention

Danger of damaging the units. The unit must not be subjected to the weight of the ducts. Suspend the ducts from the ceiling or support them on the floor.

Connecting the supply air duct

- Connect RoofVent® units without Air-Injectors or with 2 Air-Injectors to a on-site air duct.
- For units with 2 Air-Injectors: Install the two Air-Injectors on the supply air duct:
 - Stick the compression tape onto the Air-Injectors.
 - Attach the Air-Injectors to the supply air duct with a perforated angle plate and blind rivet nuts.
 - Do not install any add-ons or fittings in the direct outlet area. The supply air jet must be free to spread out unhindered.

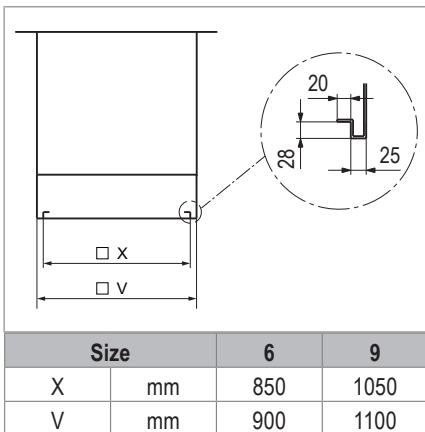

Table 29: Supply air duct connection dimensions

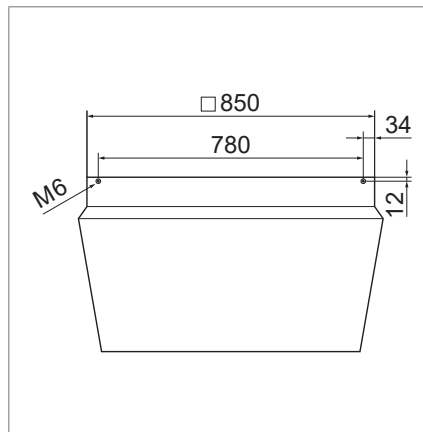
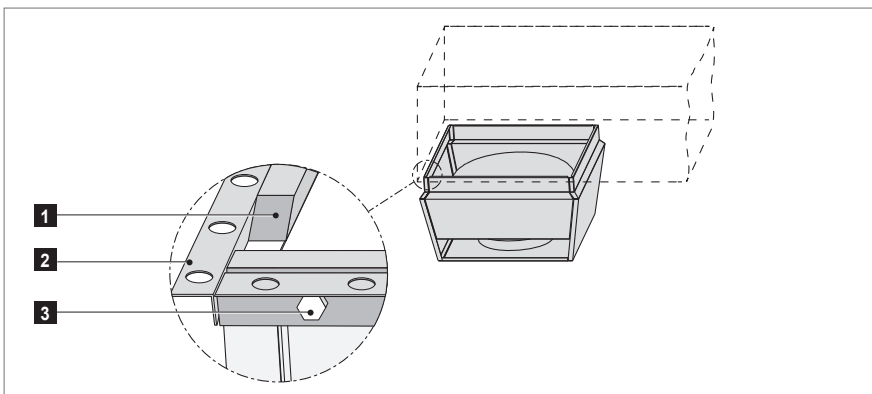

Fig. 36: Hole pattern for Air-Injector (dimensions in mm)



- 1 Compression tape (on site)
- 2 Perforated angle plate (on site)
- 3 Blind rivet nuts (on site)

Fig. 37: Installing the Air-Injectors on the supply air duct

7.7 Refrigeration system installation



Caution

The refrigerant pipes must be installed by a qualified refrigeration technician in line with the local regulations.

Connection points on the heat pump

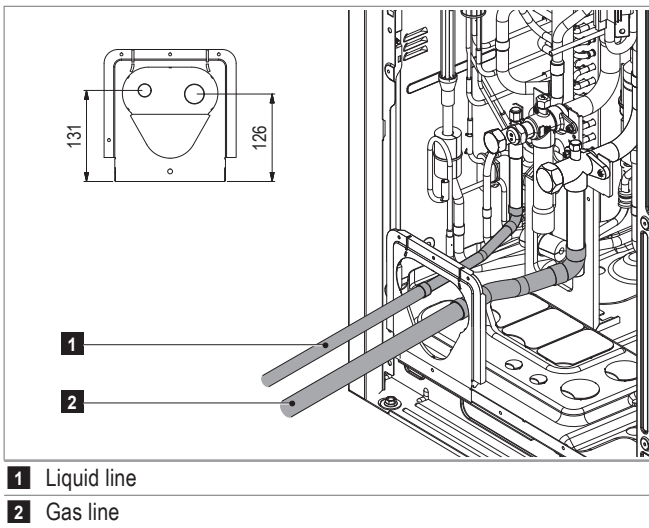

- 1** Liquid line
- 2** Gas line

Fig. 38: Opening for refrigerant pipes in the front

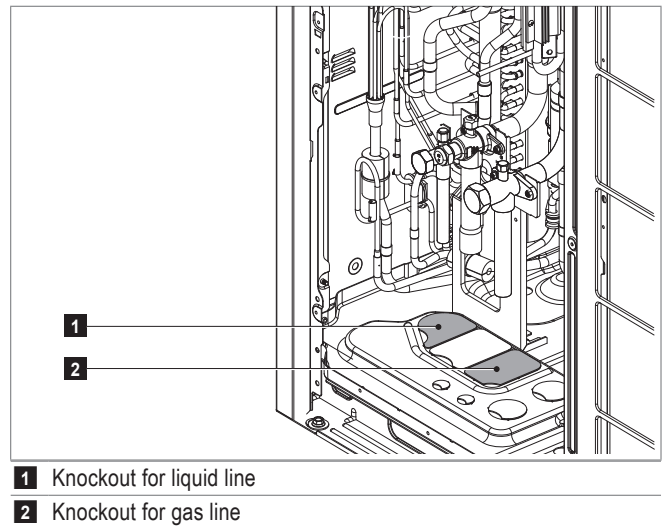

- 1** Knockout for liquid line
- 2** Knockout for gas line

Fig. 39: Opening for refrigerant pipes in the bottom

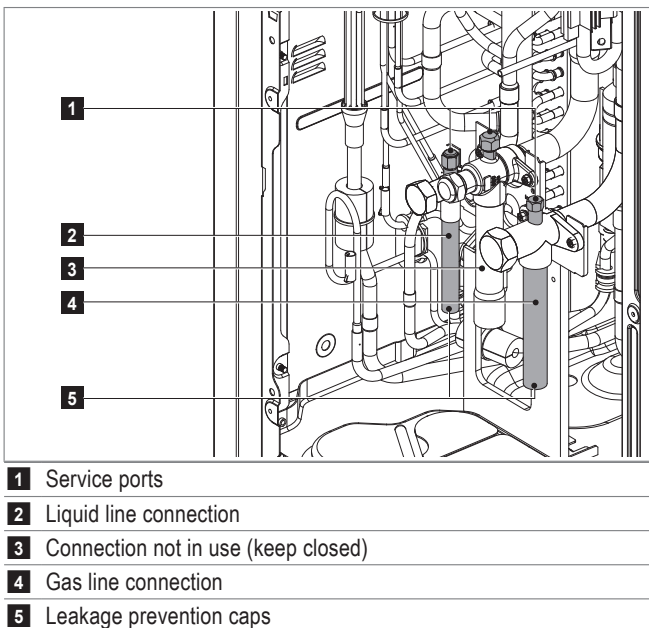

- 1** Service ports
- 2** Liquid line connection
- 3** Connection not in use (keep closed)
- 4** Gas line connection
- 5** Leakage prevention caps

Fig. 40: Refrigerant pipe connections

Before installing the refrigerant pipes, remove the leakage prevention caps:

- Ensure that all pipes are closed.
- Drain any refrigerant or air in the system via the service port.
- Remove the leakage prevention cap.

Connection points on the RoofVent® unit

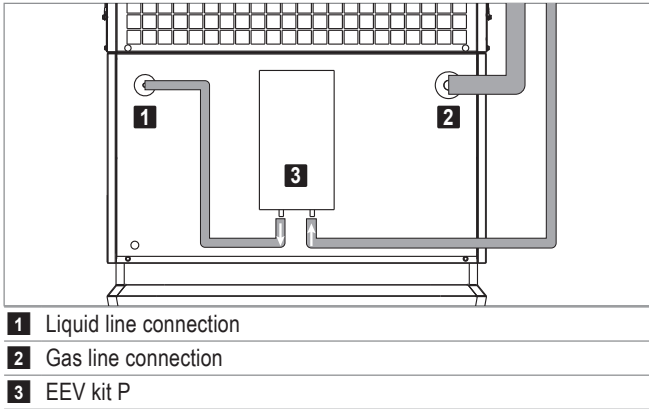

Fig. 41: Opening for refrigerant pipes in the front

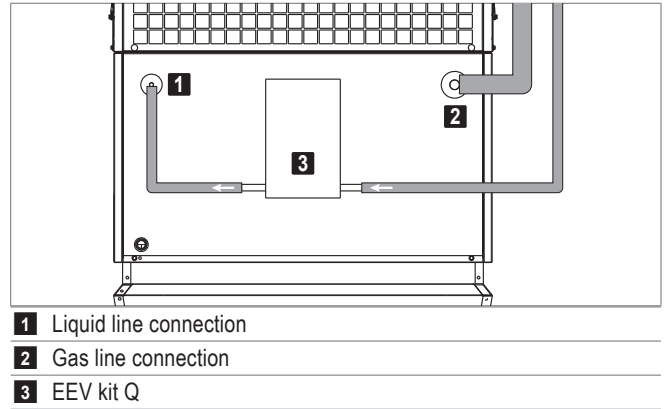
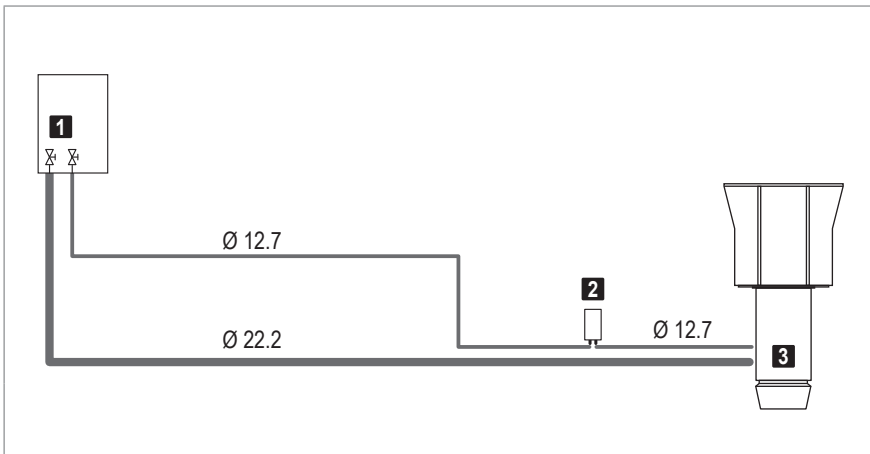

Fig. 42: Opening for refrigerant pipes in the bottom

Refrigerant pipes for heat pump P



- 1** Connections on the heat pump
 - Liquid line Ø 12.7 mm
 - Gas line Ø 22.2 mm
- 2** EEV kit P, supplied loose, connection Ø 12.7 mm
- 3** Connections on heating/cooling coil:
 - Unit size 6:**
 - Liquid line Ø 12 mm
 - Gas line Ø 22 mm
 - Unit size 9:**
 - Liquid line Ø 12 mm
 - Gas line Ø 28 mm

Fig. 43: Refrigerant pipes for heat pump P (pipe diameters in mm)

Refrigerant pipes for heat pump Q

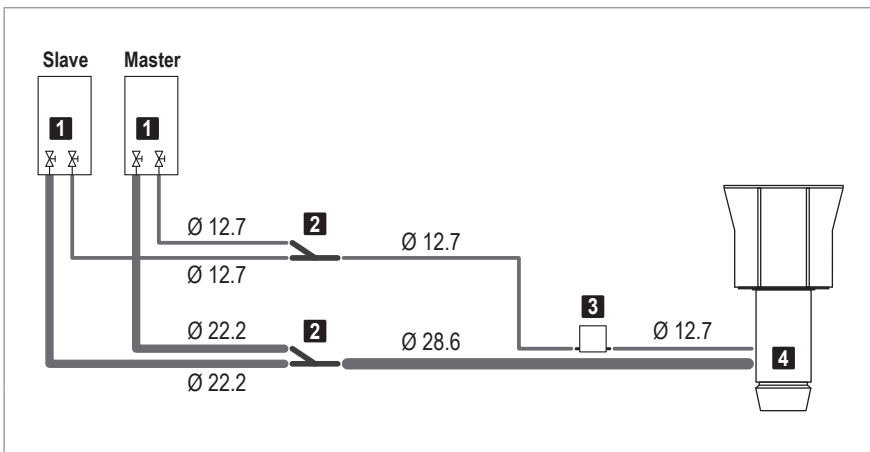

- 1** Connections on the heat pump
 - Liquid line Ø 12.7 mm
 - Gas line Ø 22.2 mm
- 2** Branch joint kit, supplied loose
- 3** EEV kit Q, supplied loose, connection Ø 19.05 mm
- 4** Connections on heating/cooling coil:
 - Liquid line Ø 12 mm
 - Gas line Ø 28 mm

Fig. 44: Refrigerant pipes for heat pump Q (pipe diameters in mm)

Notes on installation

- To avoid damaging the unit:
 - Do not use any flux.
 - Ensure there is a nitrogen supply when soldering.
 - Protect the unit against excessive heat with a wet cloth.
- Install the refrigerant pipes as shown in Fig. 43 and Fig. 44 schematically according to the local conditions.
- The maximum length of the liquid line is 40 m.
- The maximum height difference between the heat pump and the indoor climate unit is ± 30 m.
- The maximum length between the two single units of heat pump Q is 10 m.
- If the heat pump is placed lower than the main pipe: Install an oil return trap in the gas line.

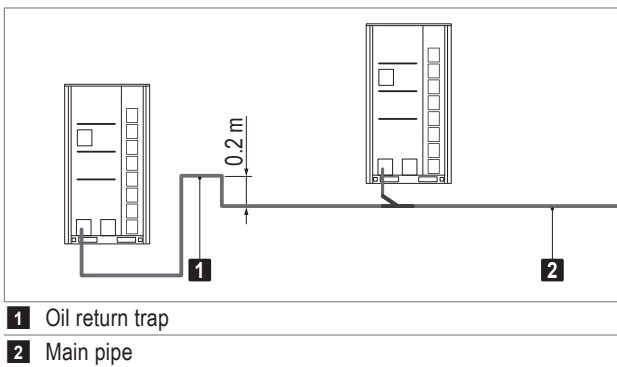

Fig. 45: Oil return trap

Heat pump Q

- The heat pump Q consists of 2 single units. Use the branching kit supplied for branching the pipeline.
 - Install the 2 Y branch joints as close as possible to the master unit.
 - Install the 2 Y branch joints horizontally so that the two branch pipes are in one plane.
- If the distance between the 2 single units is more than 2 m: Install an oil return trap in the gas line.

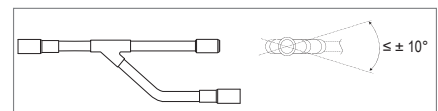

Fig. 46: Installation of the branch joint kit

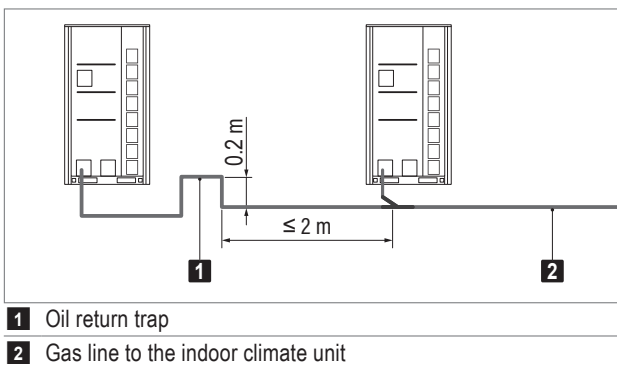

Fig. 47: Oil return trap

Installation of the temperature sensors

Install the liquid temperature sensor (Ø 6.3 mm) and the gas temperature sensor (Ø 8.2 mm):

- Solder the sleeve for the sensor to the gas line:
 - as close as possible to the heating/cooling coil
 - on the lower side of the pipe, as shown in Fig. 48
- Use thermal paste to ensure a good conductivity between the sleeve and the refrigerant pipe.
- First insert the clamp and then the sensor into the sleeve.
- Install the sensor so that no condensate accumulates in the sleeve.
- Insulate the sensor and the refrigerant pipe.
- Seal the refrigerant connections on the heating/cooling section:
 - Spray PU foam around the connections.
 - Apply the enclosed self-adhesive insulating mat around the connections.

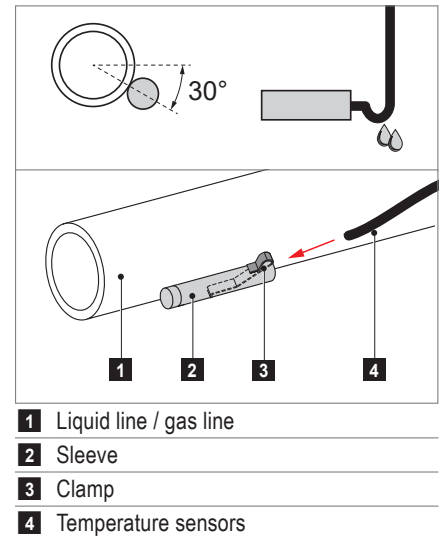

Fig. 48: Installation of the temperature sensors

Insulation of the refrigerant pipes

- The thickness of the insulation depends on the pipe diameter. Minimum thicknesses are given in Table 30. Thicker insulation is required in hot, humid environments.

| Ø | Minimum thickness ¹⁾ | Material |
|---------|---------------------------------|---|
| 12.7 mm | 15 mm | Closed-cell foam, fire protection class B1, temperature-resistant up to 120 °C, outer insulation UV-resistant |
| 22.2 mm | 20 mm | |
| 28.6 mm | 20 mm | |

¹⁾ Increase the thickness of the insulation in hot, humid environments (> 80% relative humidity).

Table 30: Insulation of the refrigerant pipes

- Insulate the refrigerant pipes completely and without gaps.
- Insulate branch joints and weld seams only after the leak-tightness test.
- Insulate the liquid line and gas line separately.



Attention

Danger of unit damage due to condensation. Insulate the refrigerant pipes and connections with appropriate care to prevent condensation forming and dripping into the hall.

Filling with refrigerant

- Carry out a leak-tightness test and vacuum drying before charging refrigerant.
 - Leak-tightness test with 3.8 MPa test pressure
 - Vacuum drying with -100.7 kPa negative pressure
- Calculate the additional refrigerant fill.

The heat pump is filled with R32 refrigerant at the factory. Depending on the length of the liquid line and depending on the size of the unit, refrigerant must also be topped up:

- 0.103 kg refrigerant per metre of liquid line length (from the heat pump to the heating/cooling coil)
- Heating/cooling coil top-up volume:

| Unit size | | 6 | 9 |
|-------------|----|-----|-----|
| Refrigerant | kg | 2.1 | 3.7 |

Table 31: Top-up volume for the heating/cooling coil

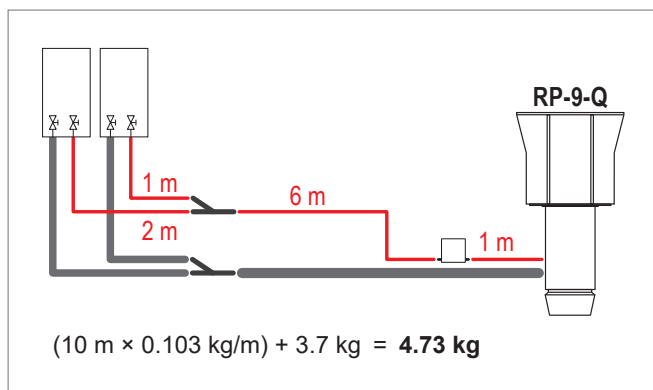

Fig. 49: Calculation example

7.8 RoofVent® condensate connection

Condensate arising in cooling units must be removed via a condensate-proof line.

- Install and insulate the supplied trap on the condensate connection of the unit.
- Dimension the slope and cross-section of the condensate line so that no condensate backflow takes place.
- Make sure that the condensate produced is drained in compliance with local regulations.

Condensate pump (option)

- Remove the transport locking device from the condensate pump.
- Install the condensate pump directly under the condensate drain connection; the supplied container is prepared for installation on the unit.
- Connect the condensate pump to a condensate-resistant waste water pipe. To do this, use a hose and attach it using a hose clamp or use a pipe with an inner diameter of 9 mm.
- Route the condensate line from the pump directly upwards.



Notice

This line must not exceed the delivery head of the pump:
– head of 3 m up to a condensate quantity of max. 150 l/h
– head of 4 m up to a condensate quantity of max. 70 l/h
Consider the condensate quantity expected in your application.
(It can be calculated with the selection program HK-Select).

- Install an odour trap at the highest point.
- Route the line with a constant incline downwards and then vertically downwards, and if possible down to below the condensate pump. This will create a siphon effect and thus improve the effectiveness of the condensate pump.
- Make sure that the condensate produced is drained in compliance with local regulations.

7.9 Heat pump condensate connection

- Make sure that the heat pump is not damaged by pooling water or ice formation:
 - Make sure that water is free to drain through the bottom plate of the heat pump.

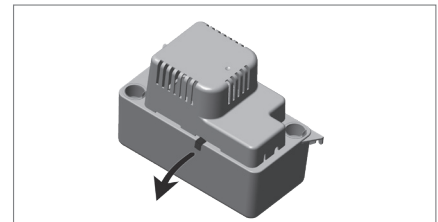

Fig. 50: Removal of the transport locking device

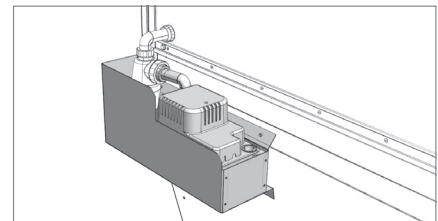

Fig. 51: Installation on the unit

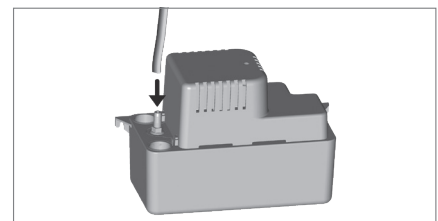

Fig. 52: Connection of the condensate pump

7.10 Electrical installation



Caution

Danger of electric shocks. The electrical installation must only be carried out by a qualified electrician.

Please note the following:

- Observe all relevant regulations (e.g. EN 60204-1).
- Choose the dimensions of the cable cross sections in line with the applicable regulations.
- Route signal and bus lines separately from mains cables.
- Make sure the lightning protection system for the units or for the entire building is planned and carried out by professionals.
- Provide overload protection equipment on site in the mains connection line of the zone control panel.
- Carry out the electrical installation according to the wiring diagram.
- Secure all connections against working loose.

RoofVent® RP unit

- When installing cables, observe the following points:
 - Fasten the cables in place with cable mounts and cable ties or with cable conduits/ducts.
 - Use blind rivets.
 - Drill holes with a maximum diameter of 5 mm Ø.
 - The maximum drilling depth is 10 mm. Use a drill bit with a depth stop.
 - The maximum load resulting from cable holders and cable guides is 10 kg.
 - All access panels must be easily removable.
 - Do not drill any holes in the connection module around the connection box and cable duct leading to the roof unit.
- Connect the connection box in the below-roof unit to the control block in the roof unit.
 - Unscrew the fan protecting plate.
 - Detach the wiring harness from the below-roof unit frame.



Attention

Danger of damaging the unit: Dropping the cable may damage the heating/cooling coil. Detach the wiring harness carefully.

- Pull out upwards the laced wiring harness from the connection module and fasten it using a cable bushing and a cable clamp.
- Depending on the length of the connection module, the wiring harness has a little excess length. Fix it with the cable clamps in the roof unit.
- Connect the cable to the control block according to wiring diagram.
- Screw the fan protecting plate tightly again. To do this, use the supplied M5 x 16 screws.
- Connect the power supply to the connection box.
- Connect the zone bus to the connection box.
- Connect the unit frame with the foundation earth electrode and attach an earthing label.
- Wire up the Air-Injector actuator and supply air temperature sensor to the connection box (see Fig. 53).
- Connect the electrical components of the heat pump system (see Fig. 54 and Fig. 55).

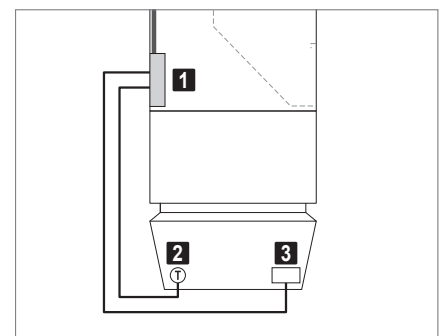

- 1 Connection box
- 2 Supply air temperature sensor
- 3 Actuator Air-Injector

Fig. 53: On-site electrical connection of the Air-Injector and supply air temperature sensor

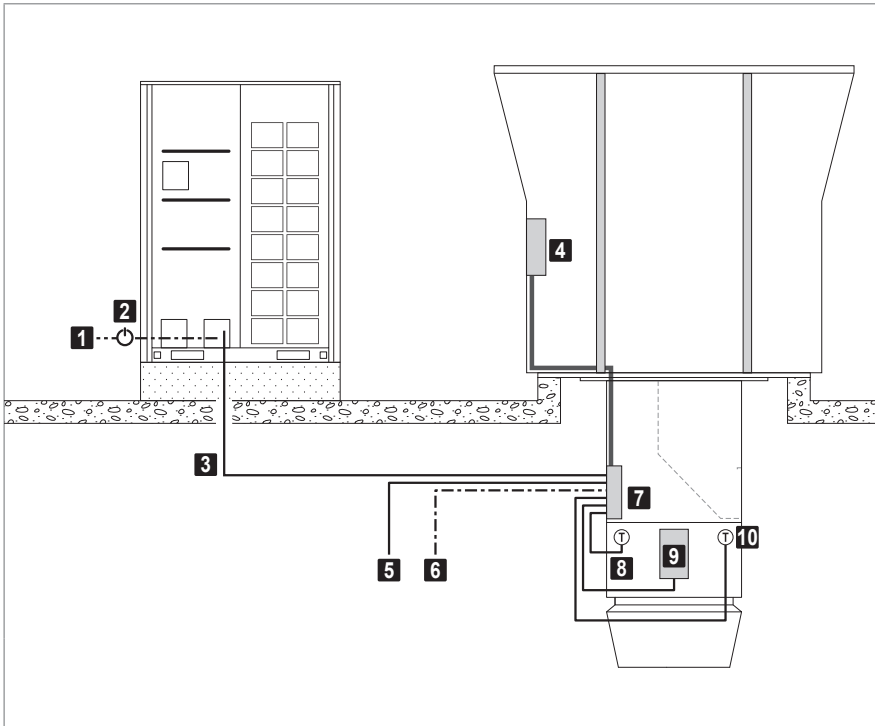

- 1 Power supply heat pump
- 2 Heat pump main switch (on-site)
- 3 Communication RoofVent®
- 4 Control block with communication kit
- 5 Zone bus
- 6 Power supply RoofVent®
- 7 Connection box
- 8 Liquid temperature sensor (supplied loose)
- 9 EEV kit (supplied loose)
- 10 Gas temperature sensor (supplied loose)

Fig. 54: Electrical connection of the heat pump system for heat pump P

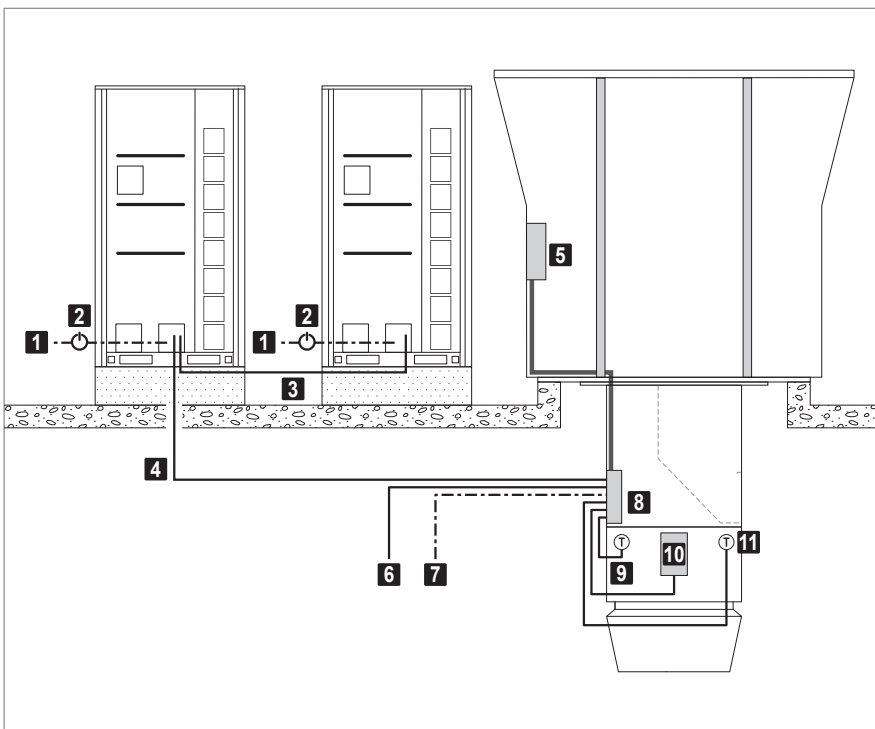

- 1 Power supply heat pump
- 2 Heat pump main switch (on-site)
- 3 Communication master-slave
- 4 Communication RoofVent®
- 5 Control block with communication kit
- 6 Zone bus
- 7 Power supply RoofVent®
- 8 Connection box
- 9 Liquid temperature sensor (supplied loose)
- 10 EEV kit (supplied loose)
- 11 Gas temperature sensor (supplied loose)

Fig. 55: Electrical connection of the heat pump system for heat pump Q

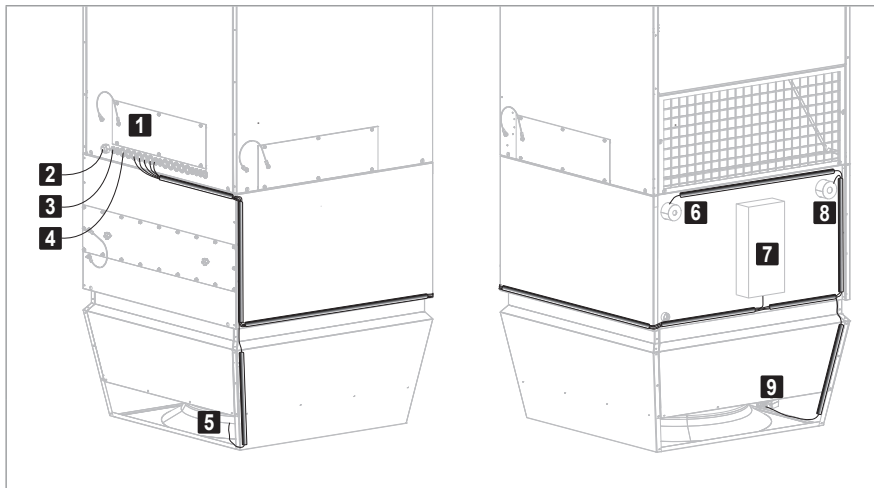

| | |
|---|-------------------------------|
| 1 | Connection box |
| 2 | Power supply RoofVent® |
| 3 | Zone bus |
| 4 | Communication RoofVent® |
| 5 | Supply air temperature sensor |
| 6 | Liquid temperature sensor |
| 7 | EEV kit |
| 8 | Gas temperature sensor |
| 9 | Actuator Air-Injector |

Fig. 56: Cable routing on the below-roof unit

RoofVent® RP options

- Condensate pump:
 - Wire up the condensate pump to the connection box.
- Design with 2 Air-Injectors:
 - Install the enclosed supply air temperature sensor in the supply air duct and wire it up to the connection box.
 - Wire up both actuators to the connection box.
- Design without Air-Injector:
 - Install the enclosed supply air temperature sensor in the supply air duct and wire it up to the connection box.
- Forced off:
 - Wire up the signal for emergency switch-off (Forced off) to the connection box.

Heat pump

- Install a leakage current protective circuit for the heat pump power supply.
- Install a main switch in view of the heat pump.
 - Heat pump Q: Install a separate main switch for each of the two single units.
- Connect the cable for the power supply to the main switch and from there route it to the connection terminals of the heat pump.
- Install the signal lines:
 - RoofVent® communication (from RoofVent® connection box to heat pump)
 - Heat pump Q: Communication master–slave

Temperature sensors

The fresh air temperature sensor and room temperature sensors are supplied loose in the control panel:

- Install the fresh air temperature sensor at least 3 m above the ground on a north-facing wall, so that it is protected from direct sunlight. Provide cover for the sensor and thermally insulate it from the building.
- Install room temperature sensors at a representative position in the occupied area at a height of about 1.5 m. The measured values must not be distorted by the presence of sources of heat or cold (machines, windows etc.). Mount the sensors on a heat-insulating base so that the measured value is not distorted by the temperature of the wall.
- Option «Combination sensor room air IP20»:
 - Protect the sensor from soiling during the construction phase by masking it with a protection film.

**Attention**

Risk of malfunctions due to dust deposits. Protect the sensor from soiling during the construction phase.

8 Operation

8.1 Initial commissioning

**Attention**

Risk of damage to property as a result of performing initial commissioning on your own authority. Initial commissioning must be performed by the manufacturer's customer service technicians.

Checklist to prepare for commissioning:

- Mechanical installation
 - Indoor climate units
 - Heat pump system
 - Zone control panels
 - Operator terminals
- Refrigeration system installation
 - Heat pump system (filled and documented)
- Hydraulic installation
 - Indoor climate units (condensate connection)
- Electrical installation
 - Power supply for indoor climate units, heat pumps, zone control panels
 - Wiring of Air-Injector actuator, supply air temperature sensor, condensate pump, forced off and components of the heat pump system to the connection box
 - Laying of bus cables conforming to wiring diagram
 - Installation and wiring of all sensors (room temperature sensor, fresh air temperature sensor, ...)
 - Wiring of external operator terminals
 - Wiring of external inputs and outputs
- Organisational matters
 - Access to all system components during commissioning (indoor climate units, operator terminals, valves, ...)
 - Provision of a suitable working platform
 - Organisation of commissioning and training (date, presence of all of the respective trade groups and of the operating personnel)

The unit is checked at the factory and preset according to the specifications on the type label.

8.2 Operation

The system runs fully automatically depending on the programmed operating times and temperature conditions.

- Observe the operating instructions for the control system.
- Check alarm displays daily.
- Correct changes to operating times in the programming accordingly.
- Ensure free air outlet and unhindered dispersion of the supply air.

9 Maintenance and repair

Caution
Risk of injury from incorrect work. Maintenance work must be carried out by trained personnel.

9.1 Safety

Before performing any work on the unit:

- Turn the isolation switch on the unit to the «Off» position and secure it against being switched back on.

Caution
Danger of electric shocks. The unit controller and the service socket are still live.

- Wait at least 3 minutes after switching the unit off.

Caution
The use of condensers can pose a danger of fatal injury from directly touching live parts even after the unit is switched off. Only open the access doors after waiting 3 minutes.

- Observe the accident prevention regulations.
- Observe the particular dangers involved when working on electrical systems.
- When working in the unit, take precautions against unprotected, sharp metal edges.
- Immediately replace damaged or removed informational and warning signs.
- Following maintenance work, professionally reassemble all dismantled protective devices.
- Replacement parts must comply with the technical requirements of the unit manufacturer. Hoval recommends the use of original spare parts.

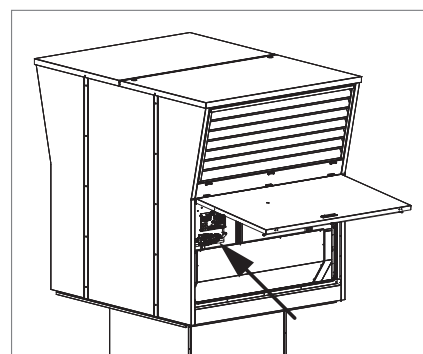

Fig. 57: Position of the isolation switch behind the supply air access door

Notice
The main switch for the heat pump is installed on site.

9.2 Maintenance

Maintenance schedule

| Activity | Procedure | Interval | | | | | | | | | | | |
|---------------------|--|--------------|----------|--|--------|--------|-----------|---------|---------|-------------|---------|---------|---|
| Clean unit | <ul style="list-style-type: none"> Clean the RoofVent® unit and the heat pump. Remove the siphon, clean it and rinse the condensate drain. | 1 × annually | | | | | | | | | | | |
| Functional check | <ul style="list-style-type: none"> Check function of the fan and actuators. Check function of the Air-Injector. Check function of the heat pump. Check function of the control system. | 1 × annually | | | | | | | | | | | |
| Changing the filter | <ul style="list-style-type: none"> Renew air filter. <table border="1" style="margin-left: 20px;"> <thead> <tr> <th rowspan="2">Filter set</th> <th colspan="2">Mat. no.</th> </tr> <tr> <th>Size 6</th> <th>Size 9</th> </tr> </thead> <tbody> <tr> <td>Fresh air</td> <td>6046475</td> <td>6046474</td> </tr> <tr> <td>Extract air</td> <td>6046477</td> <td>6046476</td> </tr> </tbody> </table> | Filter set | Mat. no. | | Size 6 | Size 9 | Fresh air | 6046475 | 6046474 | Extract air | 6046477 | 6046476 | When the filter alarm is displayed, at least 1 × annually |
| Filter set | Mat. no. | | | | | | | | | | | | |
| | Size 6 | Size 9 | | | | | | | | | | | |
| Fresh air | 6046475 | 6046474 | | | | | | | | | | | |
| Extract air | 6046477 | 6046476 | | | | | | | | | | | |

Table 32: Maintenance schedule

Changing the filter



Caution

- Danger of hazardous emissions from damaged filters:
- Only hold the filters on the black filter frame.
 - Never touch the white filter medium.
 - Replace damaged filter elements immediately.



Caution

Crushing hazard from closing dampers. Only open the access doors when the «Filter change» illuminated button is constantly illuminated (waiting period of approx. 2 min).

- Press the «Filter change» illuminated button.
- Wait until the button is constantly illuminated.
 - The button flashes whilst the speed of rotation of the fans is reduced and the dampers close; it illuminates constantly as soon as the access doors may be opened.
- Changing the extract air filter:
 - Open the extract air access door.
 - Release the filter brackets and remove the filter elements.
 - Insert the new filter elements. When doing this, only hold the frame.
 - Fix the filter elements in place with the filter brackets.
 - Close the access door.
- Changing the fresh air filter:
 - Open the fresh air access door. Release the safety loops and fold the access door down completely.
 - Release the filter brackets and remove the filter elements.
 - Insert the new filter elements. When doing this, only hold the frame.
 - Fix the filter elements in place with the filter brackets.
 - Fold the access door up and reattach the safety loops. Close the access door.
- Changing the fresh air filter when a fresh air silencer is installed:
 - Open the clamping lock of the fresh air silencer on both sides. Fold the silencer down.
 - Release the filter brackets and remove the filter elements.
 - Insert the new filter elements. When doing this, only hold the frame.
 - Fix the filter elements in place with the filter brackets.
 - Fold the silencer up and hook the clamping lock in on both sides. Secure the clamping locks with cotter pins.
- Press the «Filter change» illuminated button again to set the unit back to normal operation. The button goes out.



Notice

If the «Filter change» illuminated button is not pressed again, the unit automatically switches back to normal operation after 30 min. The button goes out.

- Dispose of the filters in accordance with local regulations.
 - The filters are fully incinerable; the disposal of used filters depends on the contents.

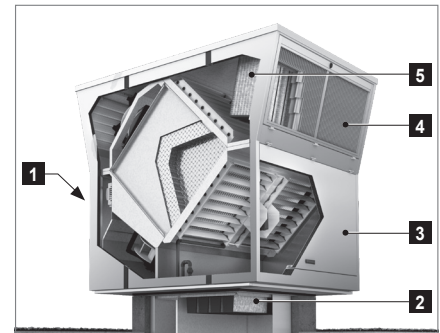

- 1 Filter change illuminated button
- 2 Extract air filter
- 3 Extract air access door
- 4 Fresh air access door
- 5 Fresh air filter

Fig. 58: Changing the filter

9.3 Repair

If required, contact Hoval customer service.

Product service life

| Component | Service life |
|--|---|
| EC motors of the supply air and exhaust air fans | approx. 30'000 to 40'000 hours depending on the application and environmental conditions |
| Damper actuators with spring return | at least 60'000 emergency positions |

Table 33: Product service life

10 Dismantling

**Caution**

Risk of injury caused by falling load and improper handling.

- Wear protective equipment (fall protection, helmet, safety shoes).
- Do not stand under suspended loads.
- Use cranes or helicopters with sufficient load-bearing capacity.
- Do not lift the two-part unit in one piece.

- Disconnect the power supply to the unit.
- Wait at least 3 minutes after switching the unit off.

**Caution**

The use of condensers can pose a danger of fatal injury from directly touching live parts even after the unit is switched off. Only open the access doors after waiting 3 minutes.

- Drain the refrigerant circuit.
- Dismantle all media connections.
- Disconnect the unit from any fastenings.
- Open the supply air access door and the extract air access door.
- Unscrew the fan protecting plate.
- Disconnect the screw connection between the roof unit and below-roof unit.
- Remove the cover caps on the unit roof.
- Screw in the transport eyes and attach the lifting gear.
- Remove the roof unit.
- Screw in the transport eyes into the connection module frame and attach the lifting gear.
- Remove the below-roof unit.

11 Disposal

- Recycle metal components.
- Recycle plastic parts.
- Dispose of electric and electronic parts via hazardous waste.
- Dispose of oil-fouled parts in accordance with local regulations.
- Dispose of the filters in accordance with local regulations.
 - The filters are fully incinerable; the disposal of used filters depends on the contents.

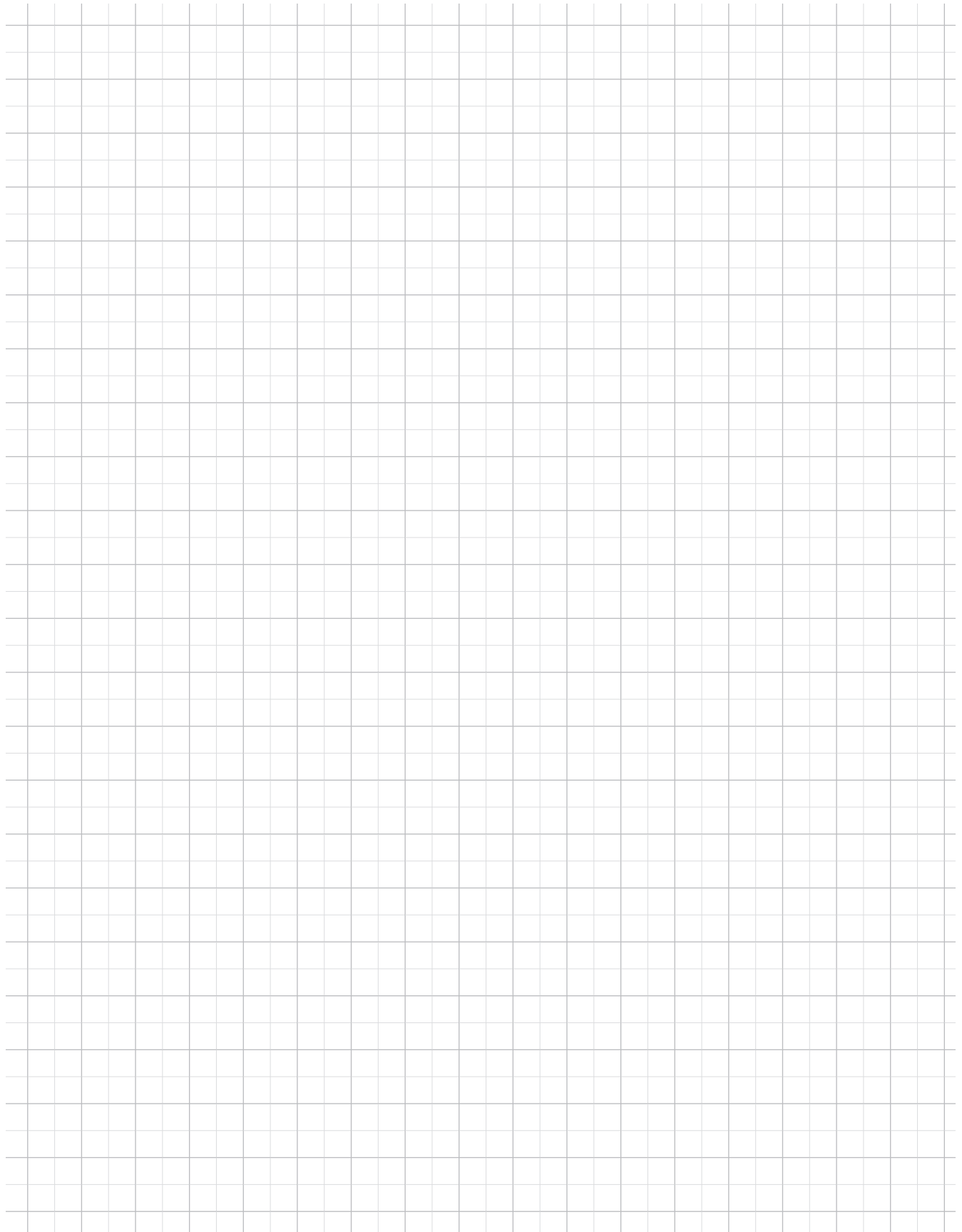

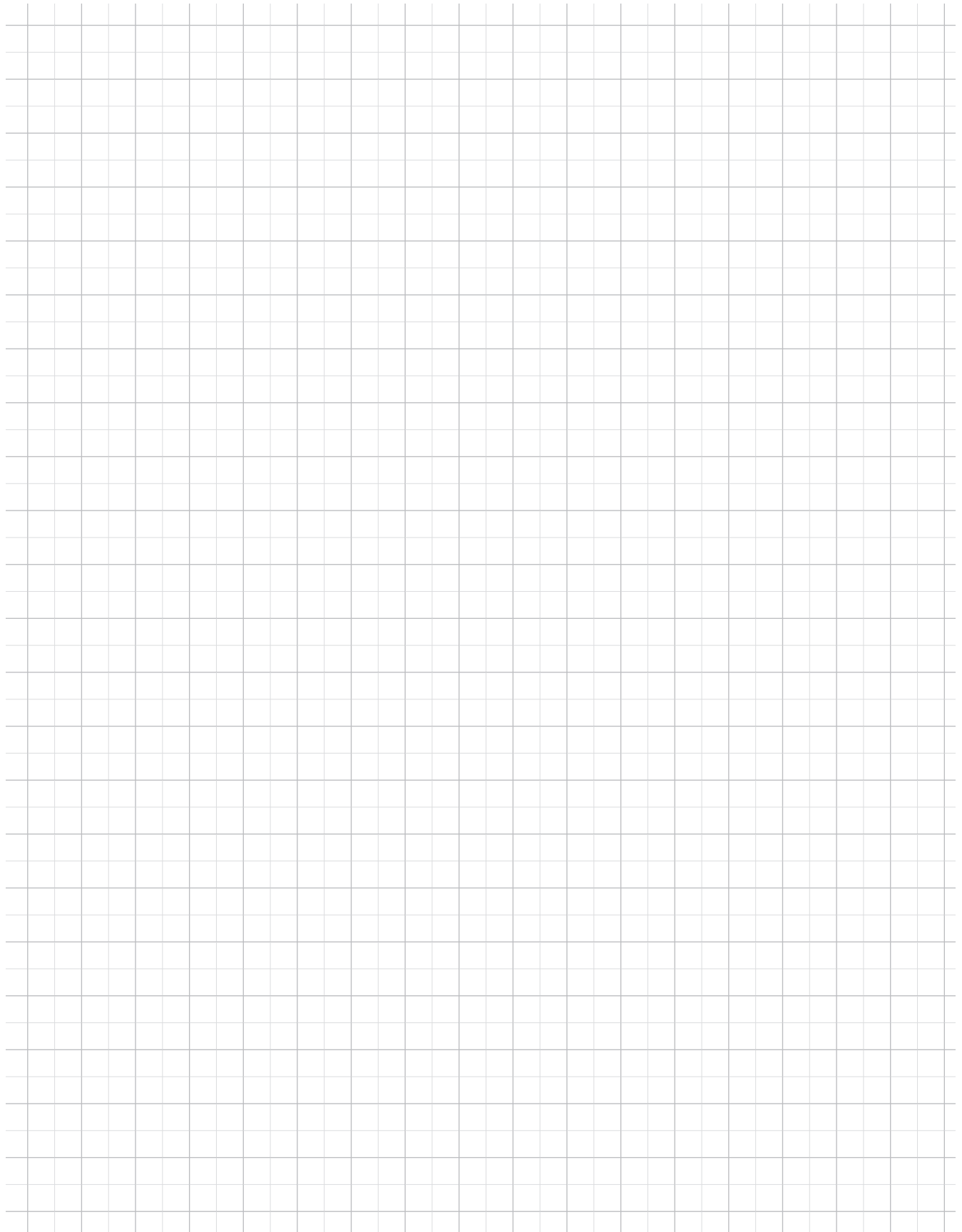

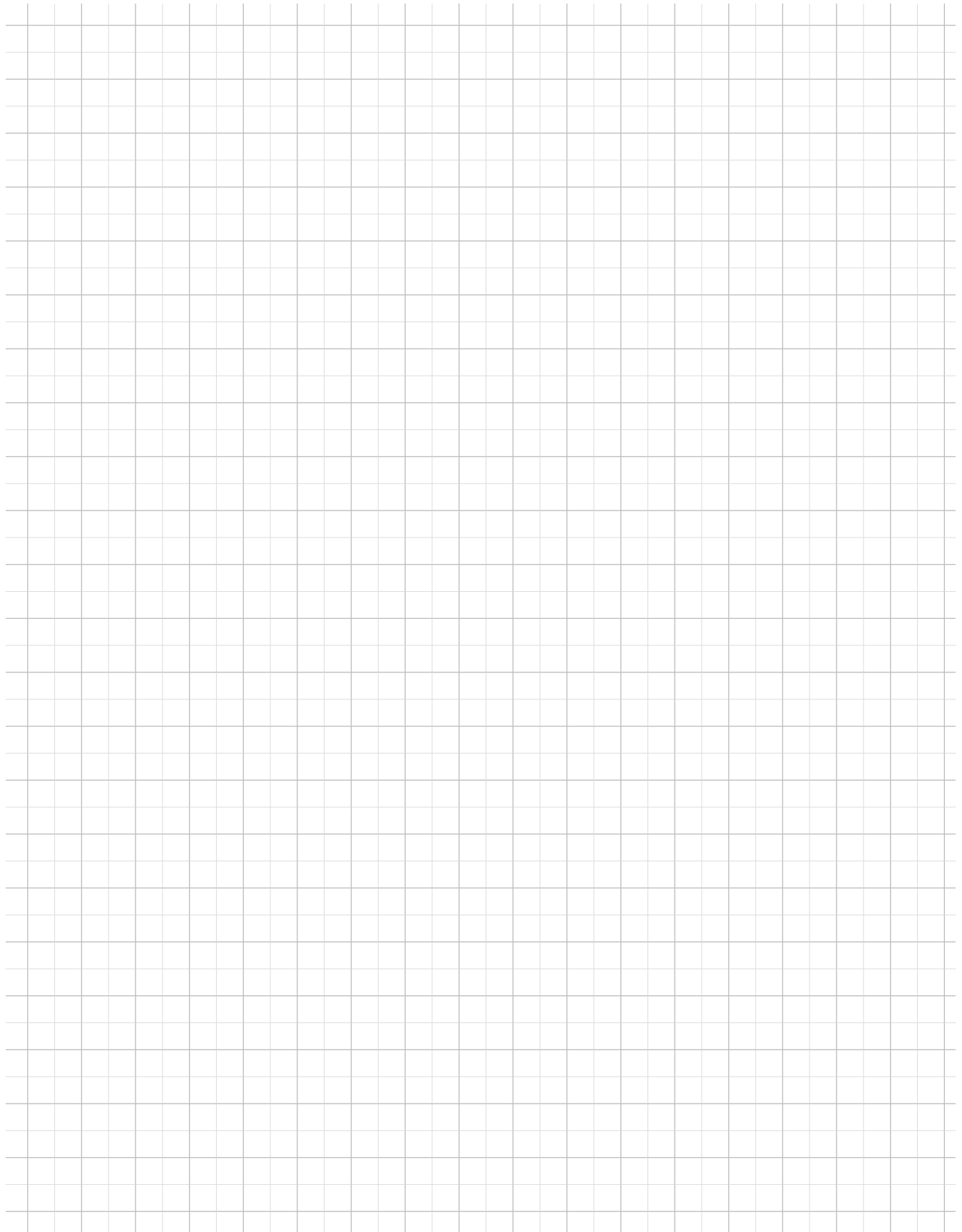

International

Hoval Aktiengesellschaft
9490 Vaduz
Liechtenstein
Tel. +423 399 24 00
info.klimatechnik@hoval.com
www.hoval.com

United Kingdom

Hoval Ltd.
Northgate, Newark
Notts
NG24 1JN
Tel. 01636 672711
hoval@hoval.co.uk
www.hoval.co.uk