

Hoval TopVent®

TP | MP

Operating instructions

Original operating
manual

4 221 902-en-02



1 Use	3		
1.1 Intended use	3		
1.2 User group	3		
2 Safety	4		
2.1 Symbols	4		
2.2 Operational safety	4		
2.3 Decommissioning	5		
3 Construction and operation	5		
3.1 Components	5		
3.2 Construction and operation TopVent® TP-6	6		
3.3 Construction and operation TopVent® TP-9	8		
3.4 Construction and operation TopVent® MP-6	10		
3.5 Construction and operation TopVent® MP-9	12		
3.6 Operating modes	14		
4 Type code	16		
4.1 Type code for recirculation units	16		
4.2 Type code for supply air units	17		
5 Technical data	18		
5.1 Application limits	18		
5.2 Electrical connection	18		
5.3 Air flow rate	19		
5.4 Air filtration	19		
5.5 Technical data of the Belaria® VRF heat pump	19		
5.6 Sound level	20		
5.7 Heat output	21		
5.8 Cooling capacity	21		
5.9 Dimensions and weights	22		
6 Options	28		
6.1 Suspension set.	28		
6.2 Air filtration	28		
6.3 Paint finish	28		
6.4 Recirculation silencer	29		
		6.5 Condensate pump	29
		6.6 Options for the heat pump	29
		7 Transport and installation	30
		7.1 Scope of delivery	30
		7.2 Storage.	31
		7.3 Requirements for the installation site	32
		7.4 Installing the heat pump	34
		7.5 Installing the TopVent® unit	37
		7.6 Refrigeration system installation	38
		7.7 Condensate connection TopVent®	42
		7.8 Heat pump condensate connection	42
		7.9 Electrical installation.	43
		8 Operation	46
		8.1 Initial commissioning	46
		8.2 Operation	46
		9 Maintenance and repair	48
		9.1 Safety	48
		9.2 Maintenance.	49
		9.3 Repair	49
		10 Dismantling	50
		11 Disposal	50

1 Use

1.1 Intended use

TopVent® TP recirculation unit

TopVent® TP units are recirculation units intended for heating and cooling spaces up to 25 m in height with decentralised heat pump. They have the following functions:

- Heating and cooling with heat pump
- Recirculation operation
- Air distribution and destratification with adjustable Air-Injector
- Air filtration (option)

The TopVent® TP unit complies with all the requirements of the Ecodesign Directive 2009/125/EC relating to environmentally friendly design of ventilation systems. It is a system of the 'fan coil unit' type, provided for in Commission Regulation (EU) 2016/2281.

TopVent® MP supply air unit

TopVent® MP units are supply air units intended for ventilation, heating and cooling spaces up to 25 m in height with decentralised heat pump. They have the following functions:

- Heating and cooling with heat pump
- Fresh air supply
- Mixed air operation
- Recirculation operation
- Air distribution and destratification with adjustable Air-Injector
- Air filtration

The TopVent® MP unit complies with all the requirements of the Ecodesign Directive 2009/125/EC relating to environmentally friendly design of ventilation systems. It is a system of the 'fan coil unit' type, provided for in Commission Regulation (EU) 2016/2281.

Intended use also includes compliance with the operating instructions. Any usage over and above this use is considered to be not as intended. The manufacturer can accept no liability for damage resulting from improper use.

1.2 User group

The units are only allowed to be installed, operated and maintained by authorised and instructed personnel who are well acquainted with the units and are informed about possible dangers.

The operating instructions are for operating engineers as well as specialists in building, heating and ventilation technology.

2 Safety

2.1 Symbols

**Caution**

This symbol warns against risk of injury. Please heed all instructions designated by this symbol to prevent injuries and/or death.

**Attention**

This symbol warns against property damage. Please heed the respective instructions to prevent risk of damage to the unit and its functions.

**Notice**

This symbol denotes information about the economic use of the equipment or special tips.

2.2 Operational safety

TopVent® units are state-of-the-art and safe to operate. All control and safety valves are checked at the factory. Nevertheless, hazards may emanate from the units if they are used incorrectly or not used as intended. Therefore:

- The unit may only be installed, operated and serviced by authorised, trained and instructed skilled personnel:
 - Specialists as defined by these operating instructions are those persons who, based on their training, knowledge and experience as well as their knowledge of the relevant regulations and guidelines, can carry out the work assigned to them and recognise potential hazards.
- Please read the operating instructions before unpacking, installing, commissioning and before maintaining the equipment.
- Store the operating instructions so that they are easily accessible.
- Observe any attached information and warning signs.
- Immediately replace damaged or removed informational and warning signs.
- Follow the local safety and accident prevention regulations at all times.
- Observe the particular dangers involved in working on the roof and on electrical systems.
- When working on the unit, objects (e.g. tools) could be dropped. Block off the area underneath the unit.
- Do not attach additional loads to the unit.
- When working in the unit, take precautions against unprotected, sharp metal edges.
- Wear suitable protective equipment (helmet, gloves, mouth protection, goggles).
- Following maintenance work, professionally reassemble all dismantled protective devices.
- Replacement parts must comply with the technical requirements of the system manufacturer. Hoval recommends the use of original spare parts.
- Unauthorised reconfiguration or modification of the unit is not permitted.
- Shut down the unit immediately, if any defects are ascertained that limit the operational safety.

2.3 Decommissioning

Disconnect the power supply with the main switch in the control panel.



Caution

The use of condensers can pose a danger of fatal injury from directly touching live parts even after the unit is switched off. Only open the access doors after waiting 3 minutes.

3 Construction and operation

3.1 Components

TopVent® TP recirculation unit

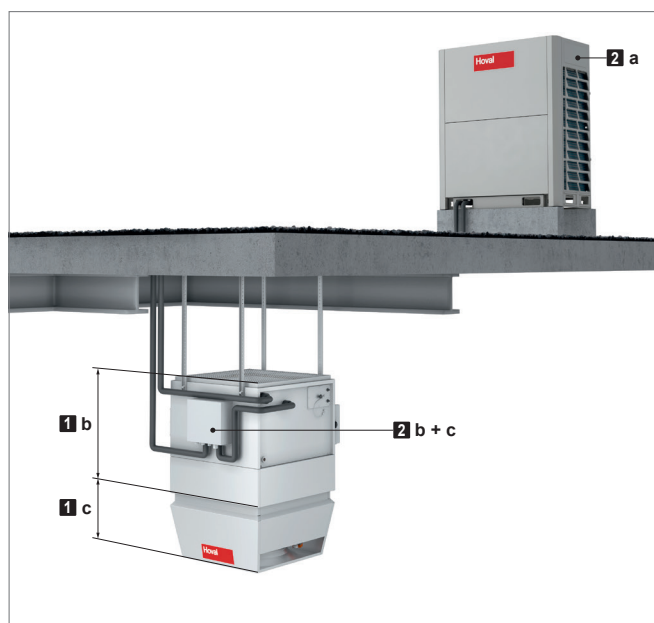

- 1** Recirculation unit
 - a** Filter box of flat filter box (not shown here)
 - b** Heating/cooling section
 - c** Air-Injector
- 2** Heat pump system
 - a** Heat pump Belaria® VRF
 - b** Conversion board (mounted in the combi box)
 - c** Expansion valve (mounted in the combi box)

Fig. 1: TopVent® TP components

TopVent® MP supply air unit

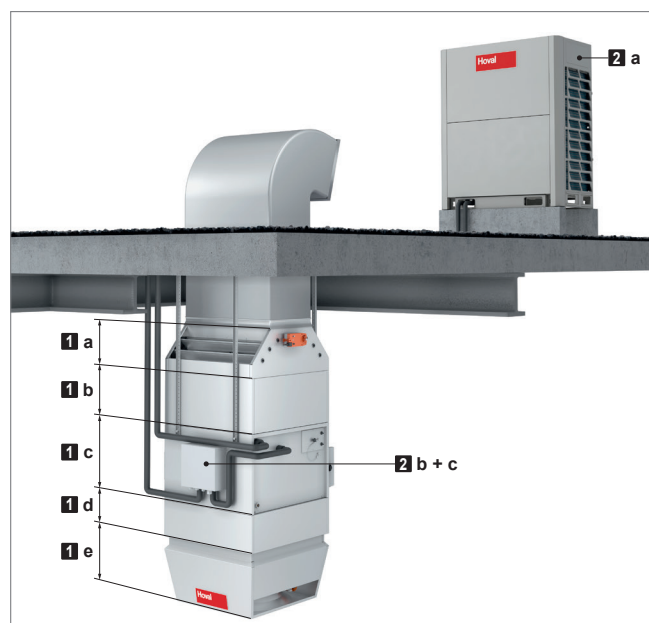

- 1** Supply air unit
 - a** Mixed air box
 - b** Filter box
 - c** Heating/cooling section
 - d** Fan unit
 - e** Air-Injector
- 2** Heat pump system
 - a** Heat pump Belaria® VRF
 - b** Conversion board (mounted in the combi box)
 - c** Expansion valve (mounted in the combi box)

Fig. 2: TopVent® MP components

3.2 Construction and operation TopVent® TP-6

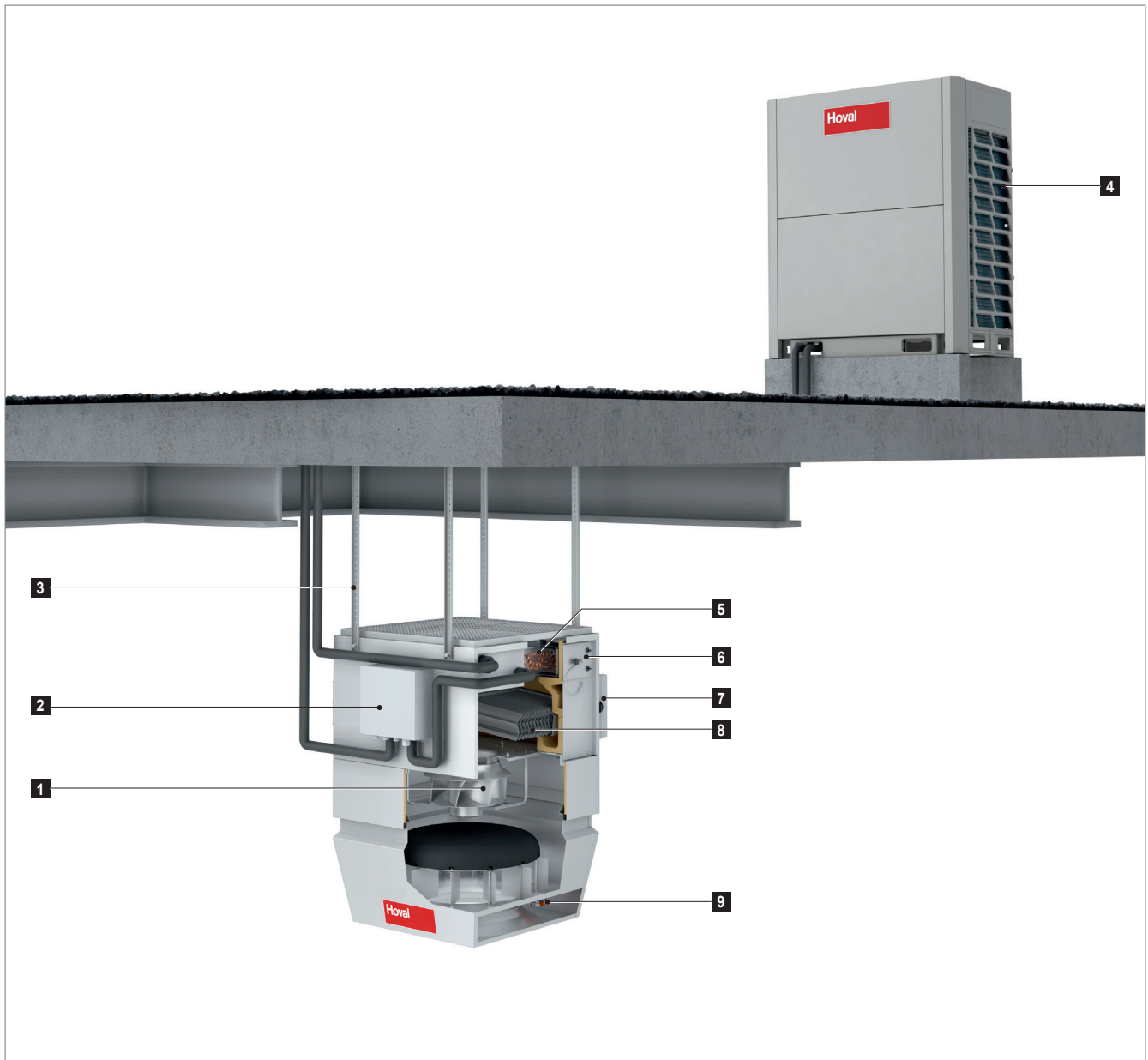

- | | |
|---|---|
| <ul style="list-style-type: none"> 1 Fan 2 Combi box with conversion board and expansion valve 3 Suspension set | <ul style="list-style-type: none"> 4 Heat pump Belaria® VRF (33, 40) 5 Heating/cooling coil 6 Access panel, liquid temperature sensor 7 Unit control box 8 Condensate separator 9 Actuator Air-Injector |
|---|---|

Fig. 3: Construction TopVent® TP-6

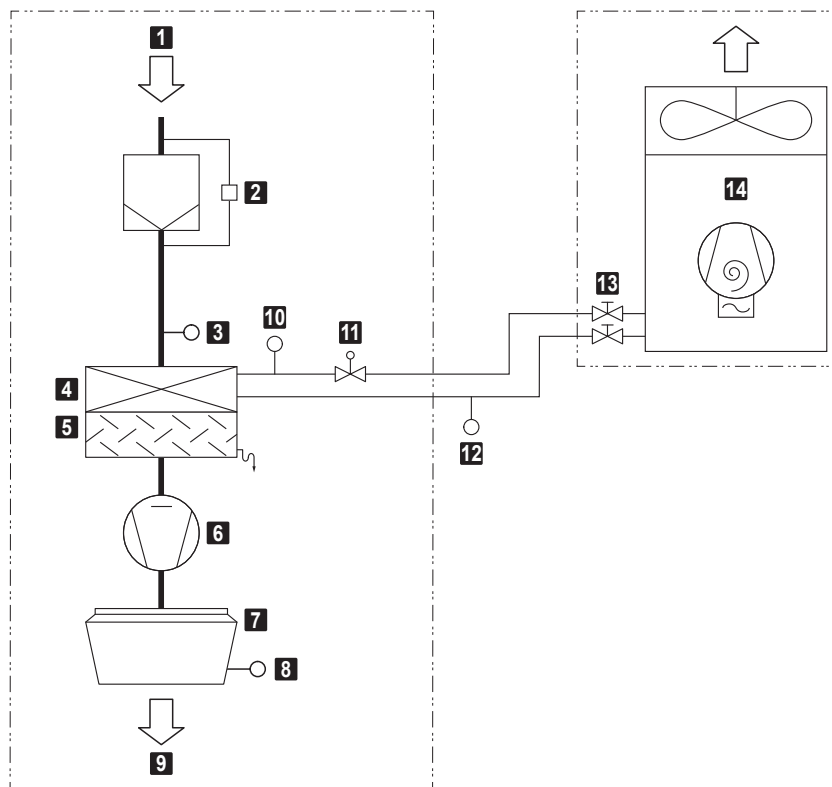

1 Extract air	8 Supply air temperature sensor
2 Air filter with differential pressure switch (optional)	9 Supply air
3 Air inlet temperature sensor heating/cooling coil	10 Liquid temperature sensor
4 Heating/cooling coil	11 Expansion valve
5 Condensate separator	12 Gas temperature sensor (supplied loose)
6 Fan	13 Shut-off valves
7 Air-Injector with actuator	14 Heat pump Belaria® VRF (33, 40)

Table 1: Function diagram TopVent® TP-6

3.3 Construction and operation TopVent® TP-9

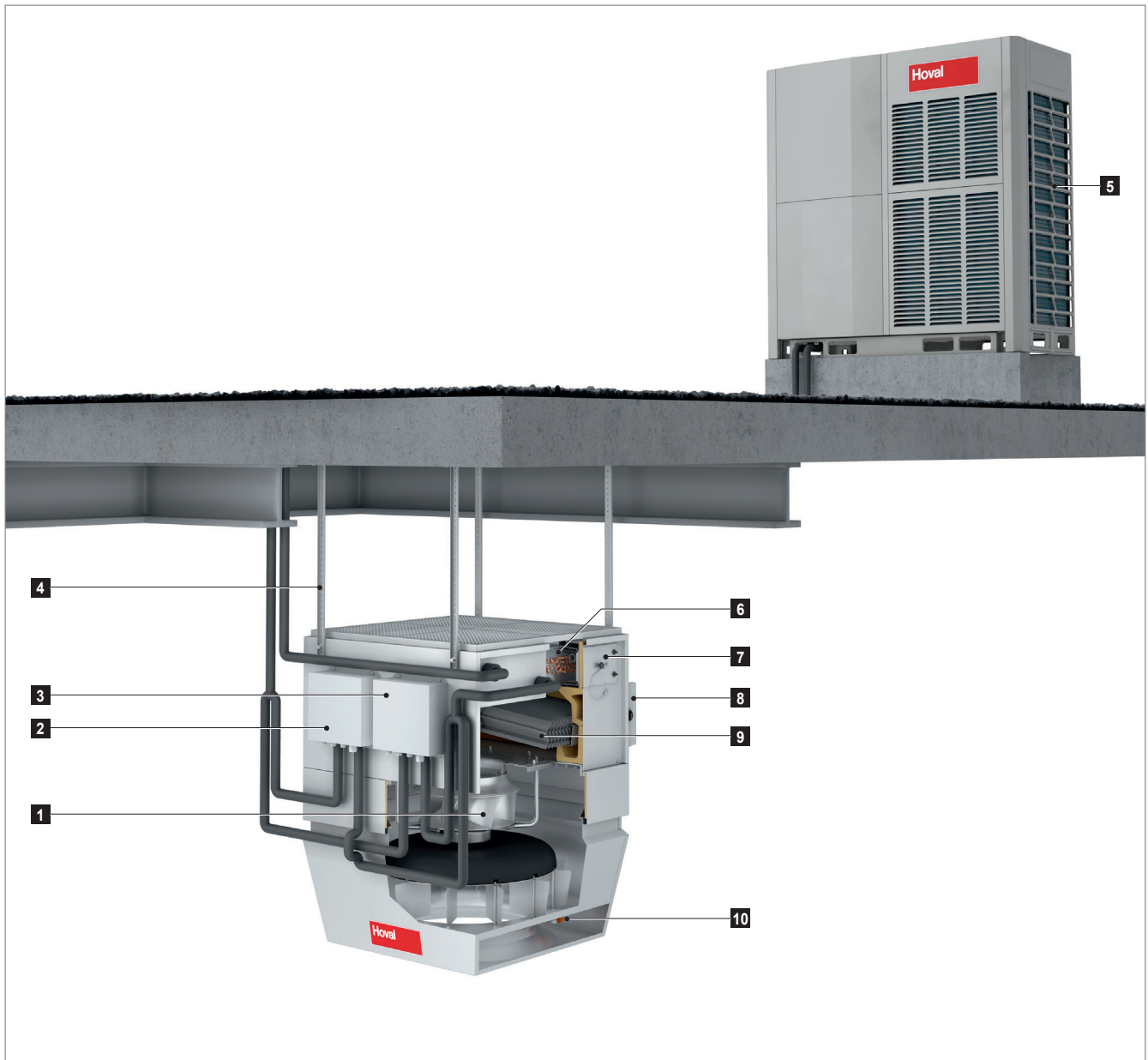

- | | |
|---|--|
| 1 Fan | 6 Heating/cooling coil |
| 2 Combi box VRF 02 with conversion board and expansion valve | 7 Access panel, liquid temperature sensor |
| 3 Combi box VRF 03 with conversion board and expansion valve | 8 Unit control box |
| 4 Suspension set | 9 Condensate separator |
| 5 Heat pump Belaria® VRF (67) | 10 Actuator Air-Injector |

Fig. 4: Construction TopVent® TP-9

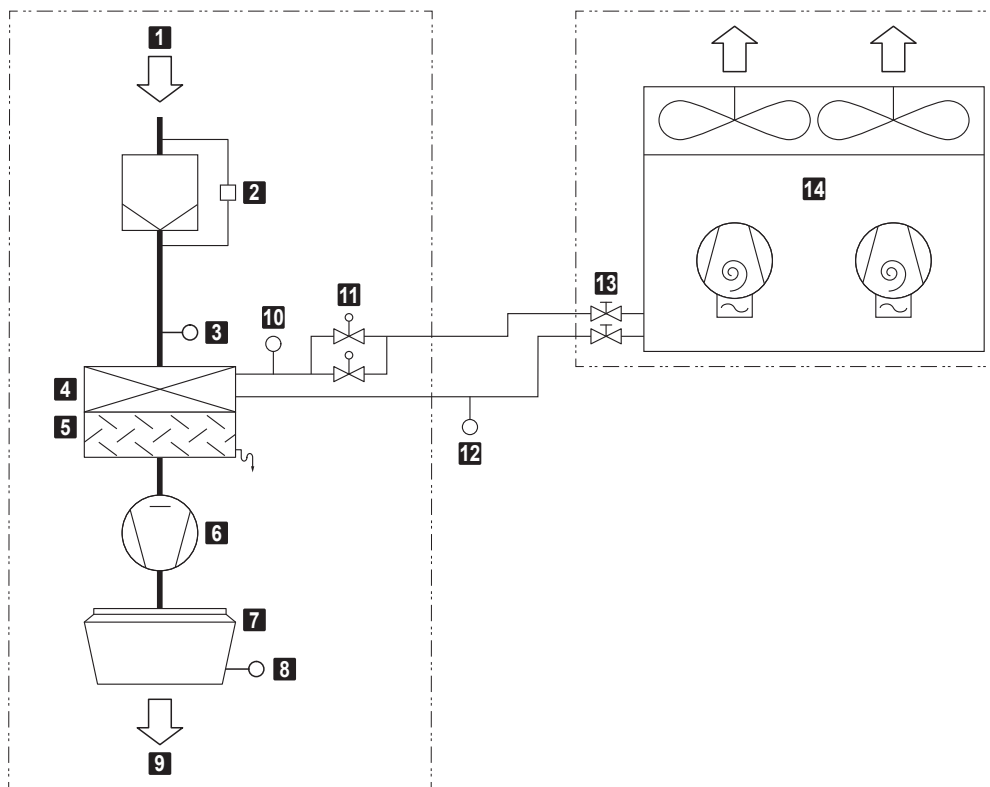

1 Extract air	8 Supply air temperature sensor
2 Air filter with differential pressure switch (optional)	9 Supply air
3 Air inlet temperature sensor heating/cooling coil	10 Liquid temperature sensor
4 Heating/cooling coil	11 Expansion valves
5 Condensate separator	12 Gas temperature sensor (supplied loose)
6 Fan	13 Shut-off valves
7 Air-Injector with actuator	14 Heat pump Belaria® VRF (67)

Table 2: Function diagram TopVent® TP-9

3.4 Construction and operation TopVent® MP-6

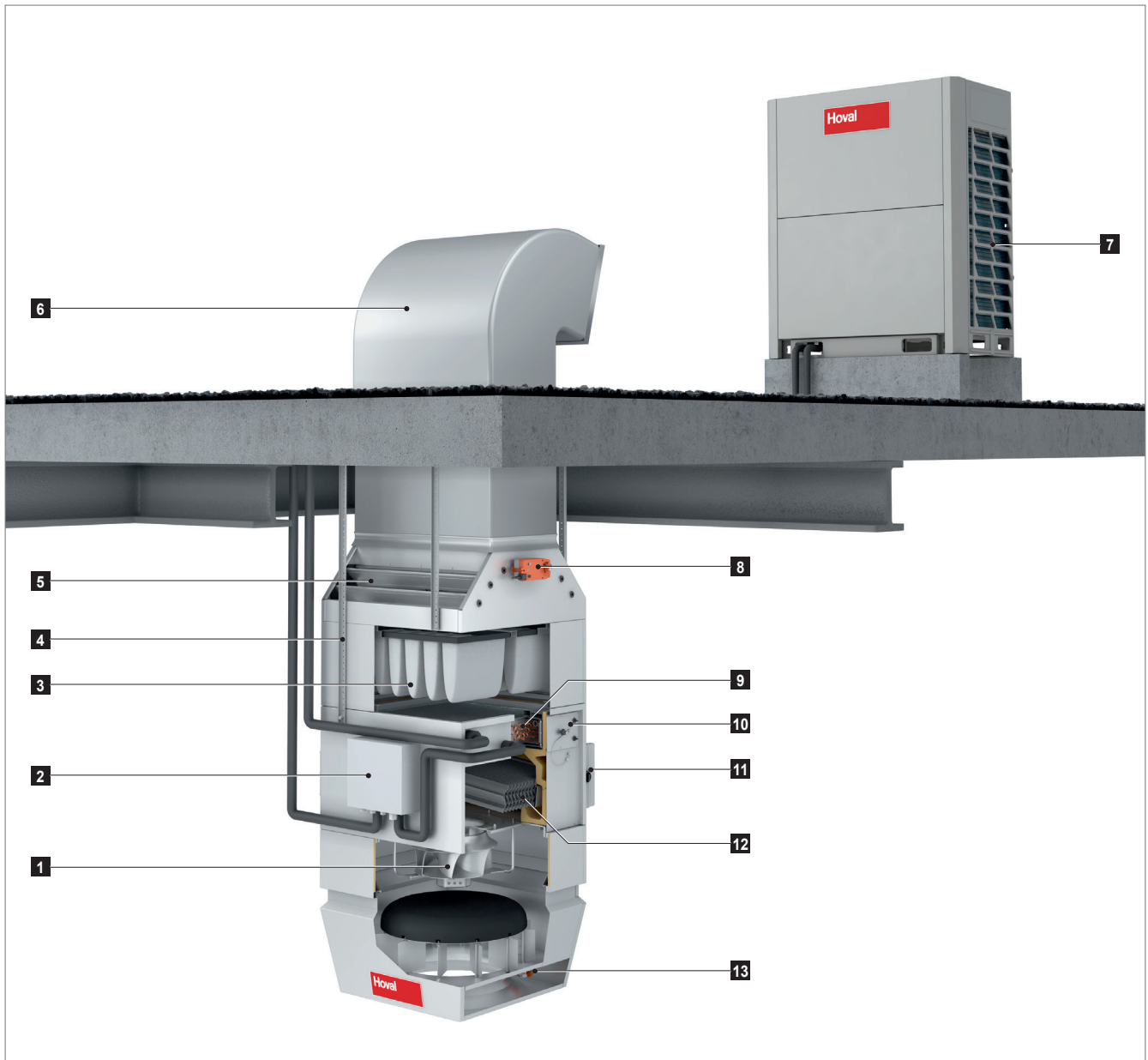

- | | |
|--|---|
| 1 Fan | 8 Fresh air damper actuator |
| 2 Combi box with conversion board and expansion valve | 9 Heating/cooling coil |
| 3 Air filter | 10 Access panel, liquid temperature sensor |
| 4 Suspension set | 11 Unit control box |
| 5 Recirculation damper | 12 Condensate separator |
| 6 Fresh air duct (field-supplied) | 13 Actuator Air-Injector |
| 7 Heat pump Belaria® VRF (33, 40) | |

Fig. 5: Construction TopVent® MP-6

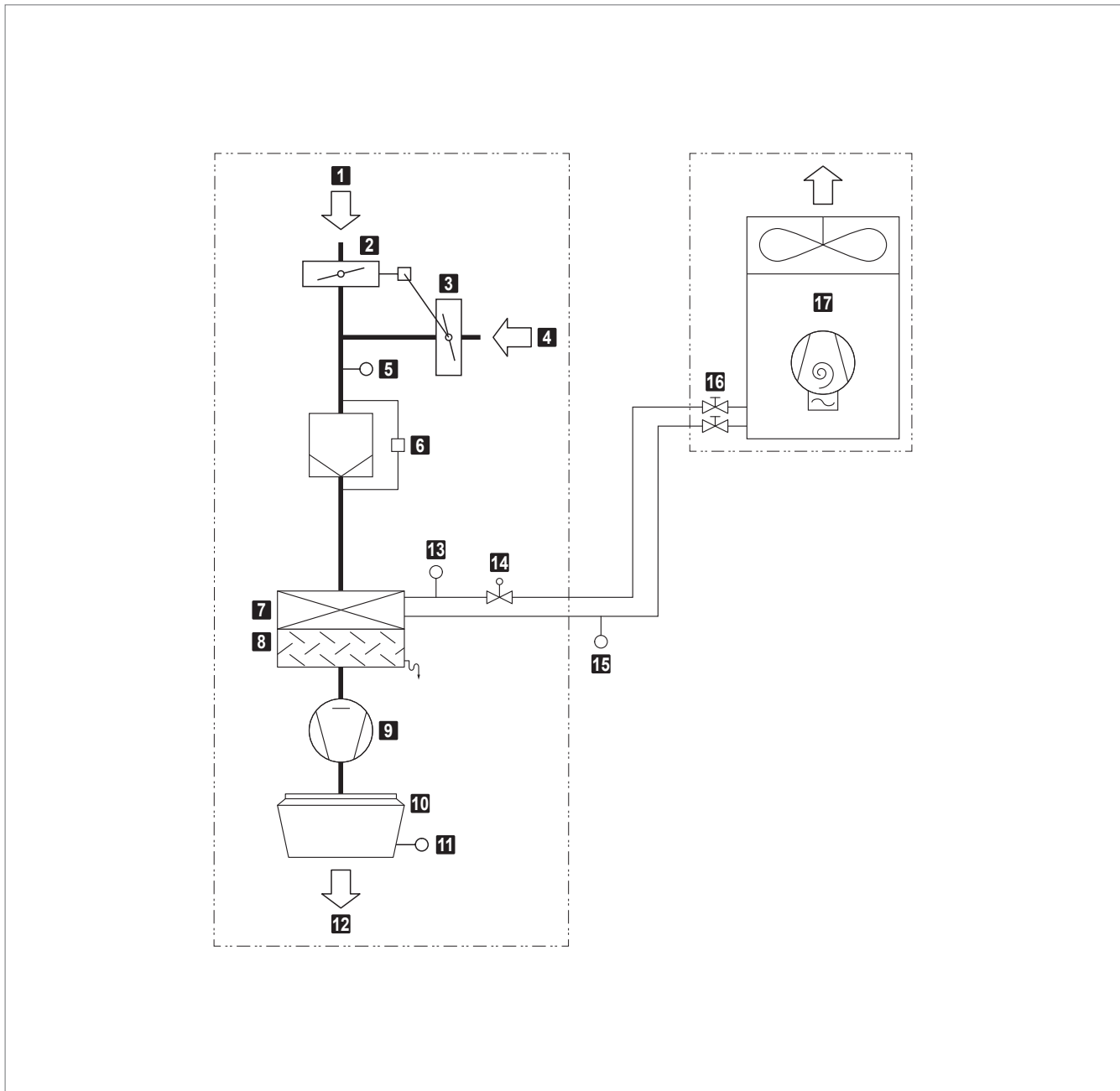

1 Fresh air	10 Air-Injector with actuator
2 Fresh air damper with actuator	11 Supply air temperature sensor
3 Recirculation damper (opposed to the fresh air damper)	12 Supply air
4 Extract air	13 Liquid temperature sensor
5 Mixed air temperature sensor	14 Expansion valve
6 Air filter with differential pressure switch	15 Gas temperature sensor (supplied loose)
7 Heating/cooling coil	16 Shut-off valves
8 Condensate separator	17 Heat pump Belaria® VRF (33, 40)
9 Fan	

Table 3: Function diagram TopVent® MP-6

3.5 Construction and operation TopVent® MP-9

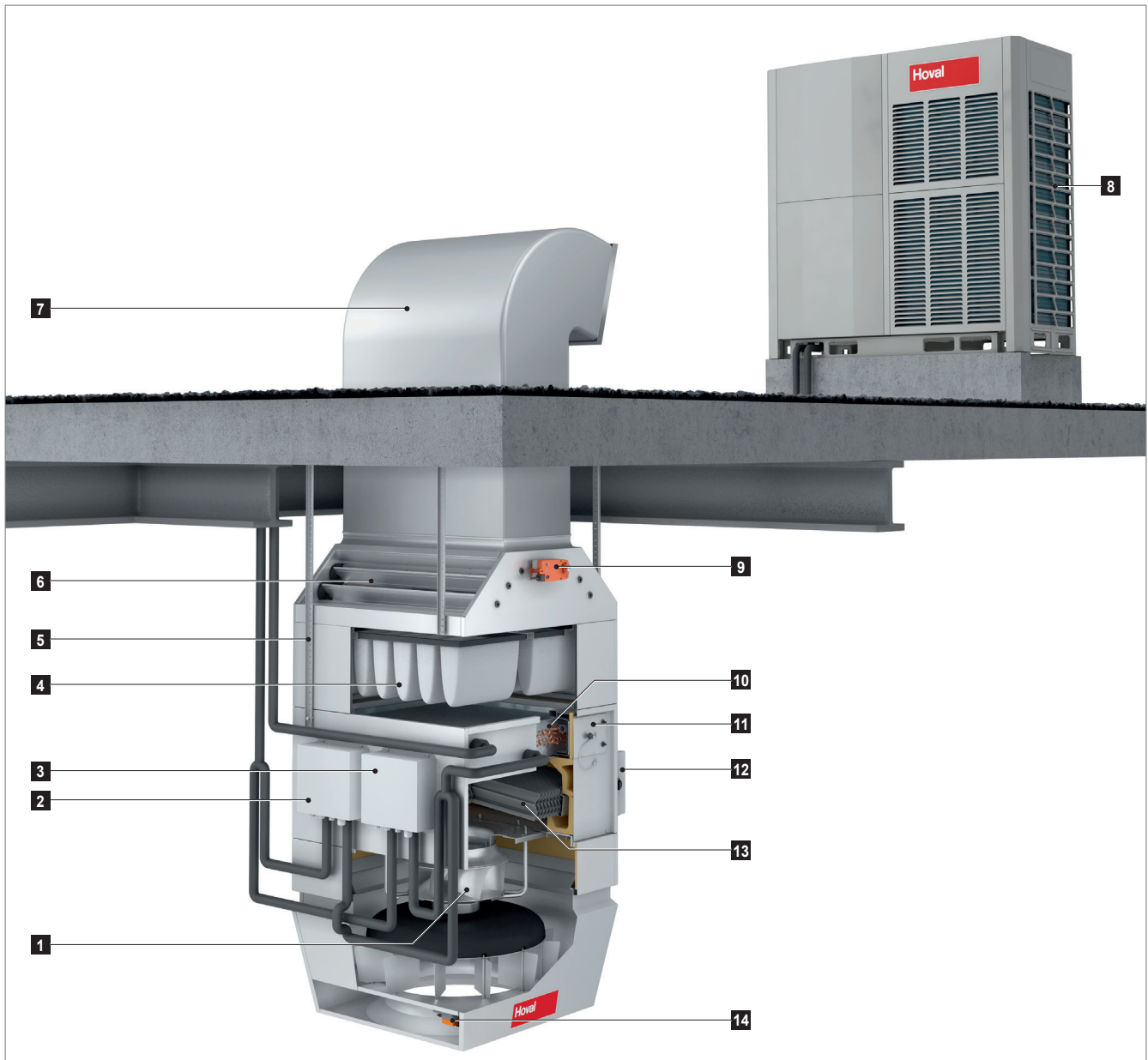

- | | |
|---|--|
| <ul style="list-style-type: none"> 1 Fan 2 Combi box VRF 02 with conversion board and expansion valve 3 Combi box VRF 03 with conversion board and expansion valve 4 Air filter 5 Suspension set 6 Recirculation damper 7 Fresh air duct (field-supplied) | <ul style="list-style-type: none"> 8 Heat pump Belaria® VRF (67) 9 Fresh air damper actuator 10 Heating/cooling coil 11 Access panel, liquid temperature sensor 12 Unit control box 13 Condensate separator 14 Actuator Air-Injector |
|---|--|

Fig. 6: Construction TopVent® MP-9

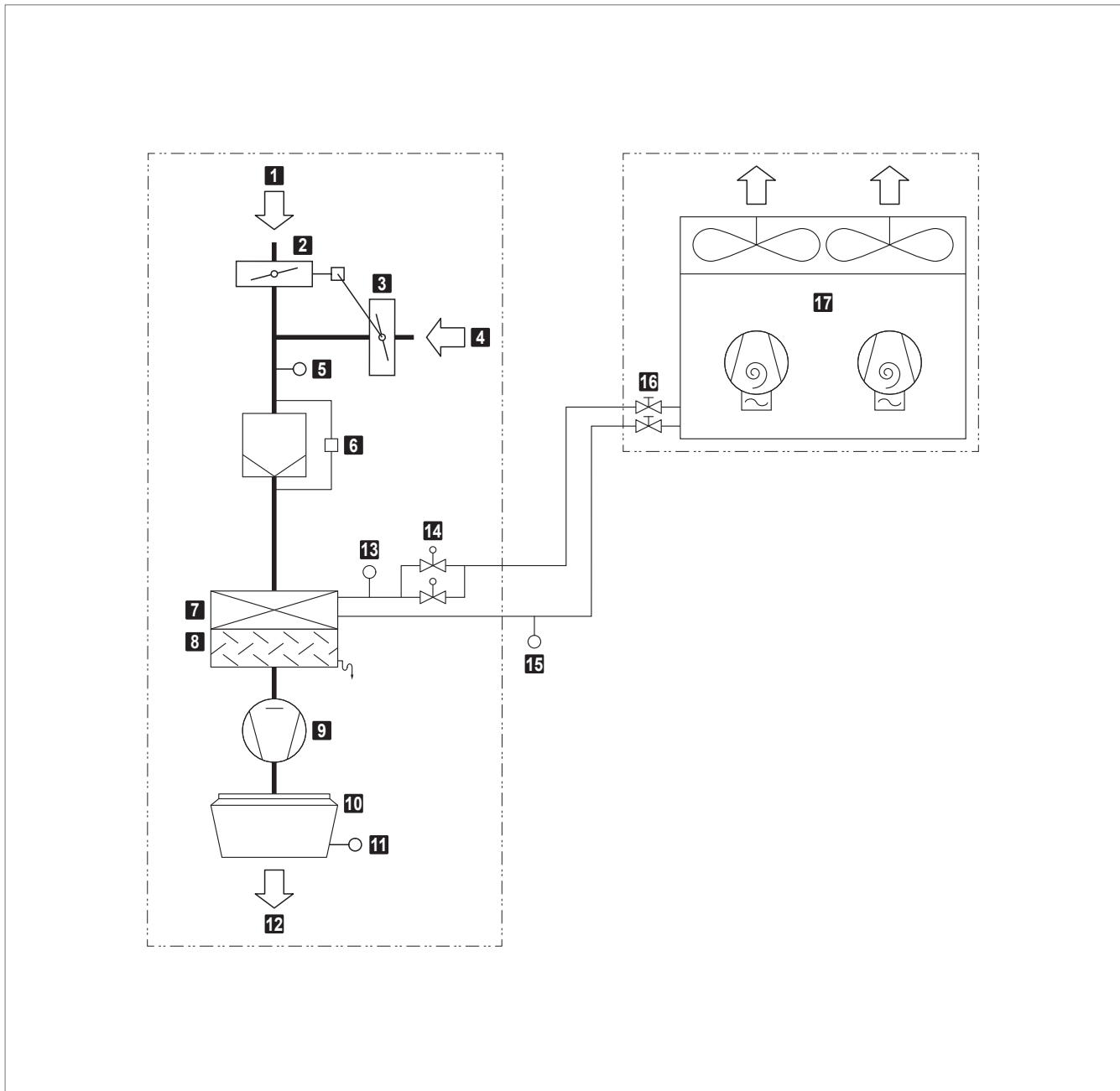

1 Fresh air	10 Air-Injector with actuator
2 Fresh air damper with actuator	11 Supply air temperature sensor
3 Recirculation damper (opposed to the fresh air damper)	12 Supply air
4 Extract air	13 Liquid temperature sensor
5 Mixed air temperature sensor	14 Expansion valves
6 Air filter with differential pressure switch	15 Gas temperature sensor (supplied loose)
7 Heating/cooling coil	16 Shut-off valves
8 Condensate separator	17 Heat pump Belaria® VRF (67)
9 Fan	

Table 4: Function diagram TopVent® MP-9



3.6 Operating modes

The units have the following operating modes:

- Supply air speed 2 (only TopVent® MP)
- Supply air speed 1 (only TopVent® MP)
- Recirculation
- Recirculation speed 1
- Standby

The TopTronic® C control system regulates these operating modes automatically for each control zone in accordance with the specifications in the calendar. The following points also apply:

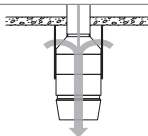
- The operating mode of a control zone can be switched over manually.
- Each TopVent® unit can operate individually in a local operating mode: Off, Supply air speed 2, Supply air speed 1, Recirculation, Recirculation speed 1 (depending on the unit type).

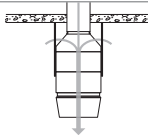
Code	Operating mode		Description
SA2	Supply air speed 2 The fan runs at speed 2 (high air flow rate). The room temperature set value day is active. The unit blows fresh air into the room. The control of the fresh air ratio can be selected:		
	<u>Fixed fresh air ratio:</u> The unit operates continuously with the set fresh air ratio. The system controls the heating/cooling according to the heating/cooling demand.		Fan speed 2 Fresh air damper..... 10 % open ¹⁾ Heating/cooling 0-100 % ²⁾ ¹⁾ Percentage is adjustable ²⁾ Depending on heat or cool demand
	<u>Variable fresh air ratio:</u> <ul style="list-style-type: none"> ■ The system regulates the fresh air ratio depending on the temperature. The set fresh air ratio serves as a minimum value. If the temperature conditions permit, more fresh air is brought into the room and used for free heating or free cooling. Only when this potential is fully utilised is the heating/cooling switched on via the coil if required. ■ If a combination sensor for room air is installed (option), the system additionally controls the fresh air ratio depending on the air quality. <ul style="list-style-type: none"> – If there is no heat demand, the fresh air damper is opened 100% if the indoor air quality is too poor. – When the setpoint value for the CO₂ or VOC content of the room air is reached, the fresh air damper closes again to the set minimum value. 		Fan speed 2 Fresh air damper..... MIN-100 % open ¹⁾ Heating/cooling 0-100 % ²⁾ ¹⁾ A minimum value can be set ²⁾ Depending on heat or cool demand
 Notice In order to save heating energy, the unit only operates with the set minimum fresh air rate when heat is required.			
SA1	Supply air speed 1 The same as SA2, but the fan operates at speed 1 (low air flow rate)		Fan speed 1 Fresh air damper..... MIN-100 % open ¹⁾ Heating/cooling 0-100 % ¹⁾ Fixed or variable (see above)

Code	Operating mode		Description
REC	Recirculation On/Off operation: during heat or cool demand, the unit draws in room air, heats or cools it and blows it back into the room. The room temperature set value day is active.		Fan speed 1/2 ¹⁾ Fresh air damper..... closed Heating/cooling on ¹⁾ ¹⁾ Depending on heat or cool demand
DES	<ul style="list-style-type: none"> ■ Destratification: To avoid heat build-up under the ceiling, it may be appropriate to switch on the fan when there is no heat or cool demand (either in permanent operation or in on/off operation depending on the temperature stratification, as desired). 		Fan speed 2 Fresh air damper..... closed Heating/cooling off
REC1	Recirculation speed 1 The same as REC, but the unit operates only at speed 1 (low air flow rate)		Fan speed 1 Fresh air damper..... closed Heating/cooling on ¹⁾ ¹⁾ Depending on heat or cool demand
DES	<ul style="list-style-type: none"> ■ Destratification: The same as for REC, but the unit operates only at speed 1 		Fan speed 1 Fresh air damper..... closed Heating/cooling off
ST	Standby The unit is ready for operation. The following operating modes are activated if required:		
CPR	<ul style="list-style-type: none"> ■ Cooling protection: If the room temperature drops below the set value for cooling protection, the unit heats up the room in recirculation operation. 		Fan speed 2 Fresh air damper..... closed Heating on
OPR	<ul style="list-style-type: none"> ■ Overheating protection: If the room temperature rises above the set value for overheating protection, the unit cools down the room in recirculation operation. 		Fan speed 2 Fresh air damper..... closed Cooling..... on
NCS	<ul style="list-style-type: none"> ■ Night cooling: If the room temperature exceeds the set value for night cooling and the current fresh air temperature permits it, the unit blows cool fresh air into the room and extracts warmer room air. 		Fan speed 2 Fresh air damper..... open Heating/cooling off
L_OFF	Off (local operating mode) The unit is switched off. Frost protection for the unit remains active.		Fan off Fresh air damper..... closed Heating/cooling off

Table 5: Operating modes

4 Type code

4.1 Type code for recirculation units

	TP	6	-	J	/	ST	.	D1	/	S	.	FK	.	LH	.	U-	/	-	.	KP	/	TC	.	-	-	-	-	
Unit type TopVent® TP																												
Unit size 6 or 9																												
Heating/cooling section J with coil type J for Belaria® VRF (33) L with coil type L for Belaria® VRF (40) N with coil type N for Belaria® VRF (67)																												
Design ST Standard																												
Air outlet D1 Design with Air-Injector																												
Installation - without S Suspension set																												
Filter box -- without FK Filter box FF Flat filter box																												
Paint finish -- without LH Standard paint finish LU Paint finish as desired																												
Silencer -- without U- Recirculation silencer																												
Condensate pump -- without KP Condensate pump																												
Control system TC TopTronic® C																												

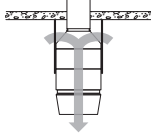
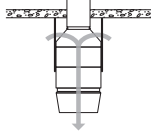
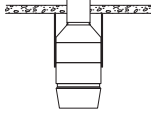
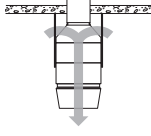
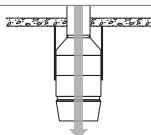
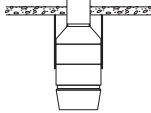
Table 6: Type code for recirculation units

4.2 Type code for supply air units

	MP	-	6	-	J	/	ST	.	D1	/	S	.	--	.	LH	.	-	/	-	.	KP	/	TC	.	--	.	--
Unit type	TopVent® MP																										
Unit size	6 or 9																										
Heating/cooling section	J with coil type J for Belaria® VRF (33) L with coil type L for Belaria® VRF (40) N with coil type N for Belaria® VRF (67)																										
Design	ST Standard																										
Air outlet	D1 Design with Air-Injector																										
Installation	- without S Suspension set																										
Paint finish	-- without LH Standard paint finish LU Paint finish as desired																										
Condensate pump	-- without KP Condensate pump																										
Control system	TC TopTronic® C																										

Table 7: Type code for supply air units

5 Technical data

5.1 Application limits

Heating mode				
Fresh air temperature		min.	°C	-25
		max.	°C	24
Air inlet temperature to the heating/cooling coil		min.	°C	5
		max.	°C	30
Cooling mode				
Fresh air temperature		min.	°C	-15
		max.	°C	48
Air inlet temperature to the heating/cooling coil		min.	°C	17
		max.	°C	32
Extract air temperature		max.	°C	50
Moisture content of extract air ¹⁾		max.	g/kg	15
Supply air temperature		max.	°C	45
Room temperature setpoint		min.	°C	15
Air flow rate	Size 6:	min.	m ³ /h	3100
	Size 9:	min.	m ³ /h	5000
Condensate quantity	Size 6:	max.	kg/h	90
	Size 9:	max.	kg/h	150
The units cannot be used in:				
<ul style="list-style-type: none"> ■ Damp locations ■ Rooms with mineral oil vapours in the air ■ Rooms with a high salt content in the air ■ Rooms with acidic or alkaline vapours in the air 				
¹⁾ Units for applications where the humidity in the room increases by more than 2 g/kg are available on request.				

Table 8: Application limits

5.2 Electrical connection

TopVent® TP, MP

Unit type		TP-6	TP-9	MP-6	MP-9
Supply voltage	V AC	3 × 400	3 × 400	3 × 400	3 × 400
Permitted voltage tolerance	%	± 5	± 5	± 5	± 5
Frequency	Hz	50	50	50	50
Connected load	kW	1.7	3.4	1.7	3.5
Current consumption max.	A	3.0	5.9	3.0	5.9
Series fuse	A	13.0	13.0	13.0	13.0
Protection rating	–	IP 54	IP 54	IP 54	IP 54

Table 9: Electrical connection TopVent® TP, MP

Heat pump Belaria® VRF

Heat pump Belaria®		VRF (33)	VRF (40)	VRF (67)
Supply voltage	V AC	3 × 400	3 × 400	3 × 400
Permitted voltage tolerance	%	± 2	± 2	± 2
Frequency	Hz	50	50	50
Connected load	kW	16.5	20.6	34.0
Current consumption max.	A	26.4	33.1	54.5
Series fuse	A	32.0	40.0	63.0
Inrush current	A	–	–	–

Table 10: Electrical connection Belaria® VRF

5.3 Air flow rate

Unit type		TP-6	TP-9	MP-6	MP-9	
Nominal air flow rate	m³/h	6000	9000	6000	9000	
Floor area covered	■ for applications with higher comfort requirements (e.g. production halls, assembly halls, sports halls)	m²	537	946	537	946
	■ for applications with low comfort requirements (e.g. warehouses, logistics centres)	m²	953	1674	–	–

Table 11: Air flow rate

5.4 Air filtration

Filter	Fresh air / Extract air
Class acc. to ISO 16890	ISO coarse 60%
Class acc. to EN 779	G4
Factory setting of differential pressure switches	180 Pa

Table 12: Air filtration

5.5 Technical data of the Belaria® VRF heat pump

Heat pump Belaria®		VRF (33)	VRF (40)	VRF (67)	
Heating	Rated heat output ¹⁾	kW	33.5	40.0	67.0
	Power consumption	kW	7.60	8.51	15.33
	COP	–	4.40	4.70	4.37
	$\eta_{s,h}$	–	173	169	151
	SCOP	–	4.41	4.31	3.86
Cooling	Rated cooling capacity ²⁾	kW	33.5	40.0	67.0
	Power consumption	kW	8.90	9.88	18.10
	EER	–	3.75	4.05	3.70
	$\eta_{s,c}$	–	285	246	277
	SEER	–	7.20	6.22	7.00
Refrigerant	–	R410A	R410A	R410A	
Refrigerant fill volume	kg	11	13	22	

1) With fresh air temperature 7 °C / extract air temperature 20 °C
 2) With fresh air temperature 35 °C / extract air temperature 27 °C / 45% rel. humidity

Table 13: Technical data Belaria® VRF

5.6 Sound level

TopVent® TP		TP-6	TP-9
Sound pressure level (at a distance of 5 m) ¹⁾	dB(A)	59	61
Total sound power level	dB(A)	81	83
Octave sound power level	63 Hz	42	48
	125 Hz	56	67
	250 Hz	65	70
	500 Hz	70	74
	1000 Hz	76	78
	2000 Hz	76	76
	4000 Hz	74	74
	8000 Hz	68	68

1) With hemispherical radiation in a low-reflection environment

Table 14: TopVent® TP sound level

Unit type		MP-6		MP-9	
		indoors	outdoors	indoors	outdoors
Sound pressure level (at a distance of 5 m) ¹⁾	dB(A)	61	55	62	55
Total sound power level	dB(A)	83	77	84	77
Octave sound power level	63 Hz	42	38	49	46
	125 Hz	53	48	68	63
	250 Hz	68	62	71	67
	500 Hz	72	68	75	69
	1000 Hz	77	70	79	71
	2000 Hz	78	72	77	71
	4000 Hz	76	70	75	69
	8000 Hz	70	64	68	64

1) with a hemispherical radiation pattern in a low-reflection room

Table 15: Sound level TopVent® MP

Heat pump Belaria®		VRF (33)	VRF (40)	VRF (67)
Sound pressure level (at a distance of 5 m)	dB(A)	59.0	63.0	67.0
Total sound power level ¹⁾	dB(A)	81.0	85.0	89.0
Octave sound pressure level ²⁾	63 Hz	62.6	63.5	66.5
	125 Hz	60.6	61.2	65.0
	250 Hz	61.0	60.8	65.0
	500 Hz	58.3	57.5	63.0
	1000 Hz	55.5	56.9	57.0
	2000 Hz	46.8	47.5	52.0
	4000 Hz	43.9	45.1	51.0
	8000 Hz	43.5	44.1	50.2

1) The values given are maximum values; the noise level is fluctuating due to scroll technology.
 2) Measured at a distance of 1 m in front of the unit and 1.3 m above the floor in a semi-anechoic chamber.

Table 16: Sound level Belaria® VRF

5.7 Heat output

			TopVent® TP recirculation units				TopVent® MP supply air units			
t_F	t_{room}	Type	Q	H_{max}	t_S	P_{HP}	Q	H_{max}	t_S	P_{HP}
°C	°C	MP-	kW	m	°C	kW	kW	m	°C	kW
-15	16	6-J	28.6	14.2	32.2	9.2	28.7	15.8	28.9	9.1
		6-L	34.2	13.2	34.9	10.3	34.3	14.4	31.7	10.2
		9-N	57.2	13.4	36.9	18.5	57.5	14.5	33.7	18.3
	20	6-J	28.5	14.3	36.1	9.4	28.6	16.1	32.5	9.2
		6-L	34.0	13.3	38.8	10.5	34.2	14.7	35.2	10.3
		9-N	57.0	13.5	40.8	18.9	57.2	14.7	37.2	18.5

Legend: t_F = Fresh air temperature
 t_{room} = Room air temperature
 Q = Heat output
 H_{max} = Maximum mounting height
 t_S = Supply air temperature
 P_{HP} = Power consumption of the heat pump

Reference: ■ At room air temperature 16 °C: extract air temperature 18 °C
 ■ At room air temperature 20 °C: extract air temperature 22 °C
 ■ Fresh air ratio 10 % for TopVent® MP supply air units

Table 17: Heat output

5.8 Cooling capacity

				TopVent® TP recirculation units					TopVent® MP supply air units				
t_F	t_{room}	RH_{room}	Type	Q_{sen}	Q_{tot}	t_S	m_C	P_{HP}	Q_{sen}	Q_{tot}	t_S	m_C	P_{HP}
°C	°C	%	MP-	kW	kW	°C	kg/h	kW	kW	kW	°C	kg/h	kW
32	26	50	6-J	23.3	34.0	16.5	15.8	8.1	23.4	34.0	16.8	15.6	8.1
			6-L	27.7	40.6	14.3	18.9	9.2	27.9	40.6	14.6	18.6	9.2
			9-N	47.1	68.0	12.5	30.7	16.9	47.4	68.0	12.8	30.3	16.9
		70	6-J	17.6	34.9	19.3	25.5	8.2	17.7	34.9	19.6	25.3	8.2
			6-L	20.9	41.7	17.6	30.5	9.3	21.1	41.7	17.9	30.2	9.3
			9-N	35.5	69.9	16.3	50.5	17.0	35.9	69.9	16.6	50.0	17.0

Legend: t_F = Fresh air temperature
 t_{room} = Room air temperature
 RH_{room} = Relative humidity of the room air
 Q_{sen} = Sensible cooling capacity
 Q_{tot} = Total cooling capacity
 t_S = Supply air temperature
 m_C = Condensate quantity
 P_{HP} = Power consumption of the heat pump

Reference: ■ At room air temperature 16 °C: extract air temperature 18 °C
 ■ At room air temperature 20 °C: extract air temperature 22 °C
 ■ Fresh air ratio 10 % for TopVent® MP supply air units

Table 18: Cooling capacity

5.9 Dimensions and weights

TopVent® TP-6

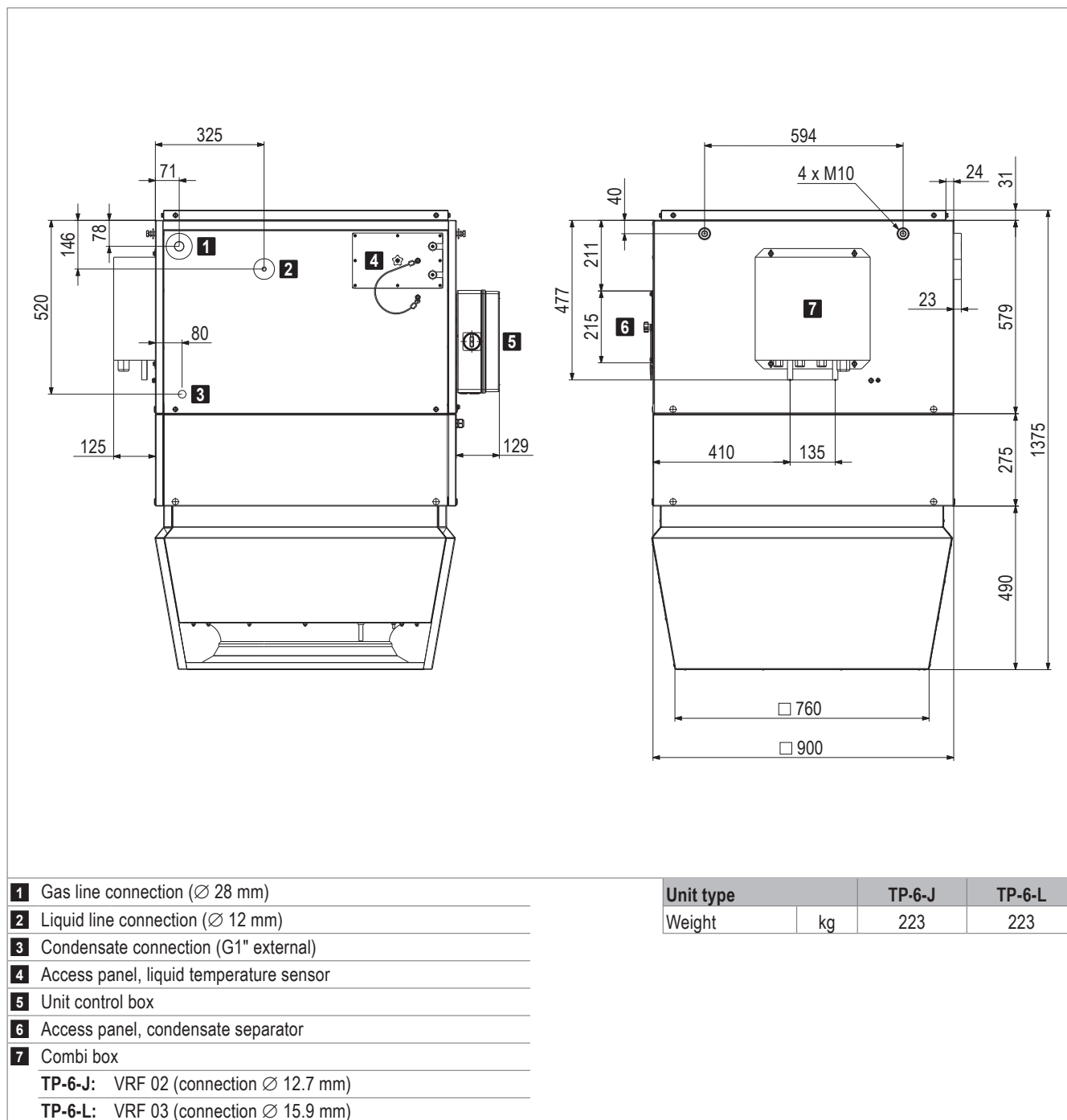

Fig. 7: Dimensions and weights TopVent® TP-6

TopVent® TP-9

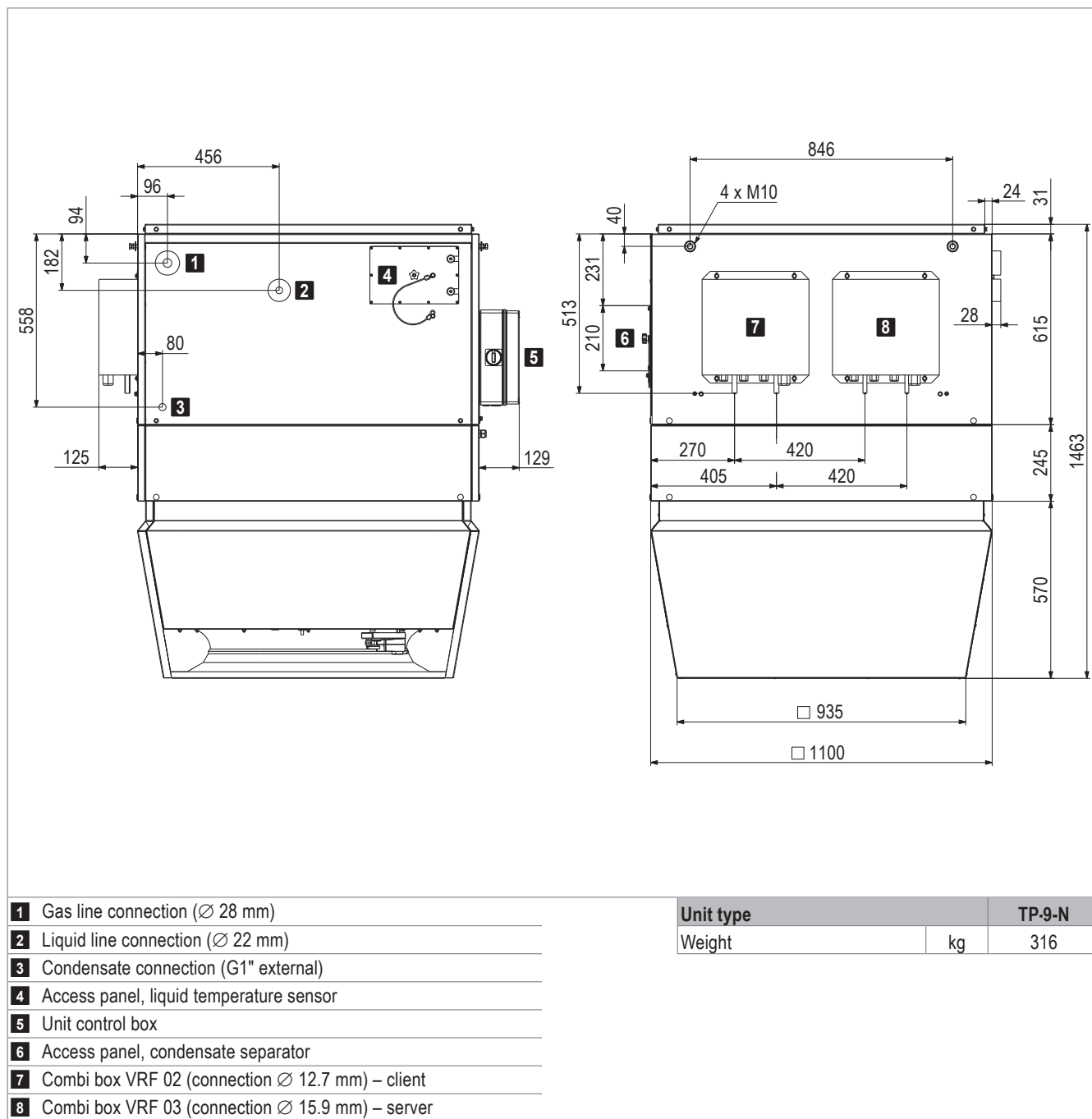

Fig. 8: Dimensions and weights TopVent® TP-9

TopVent® MP-6

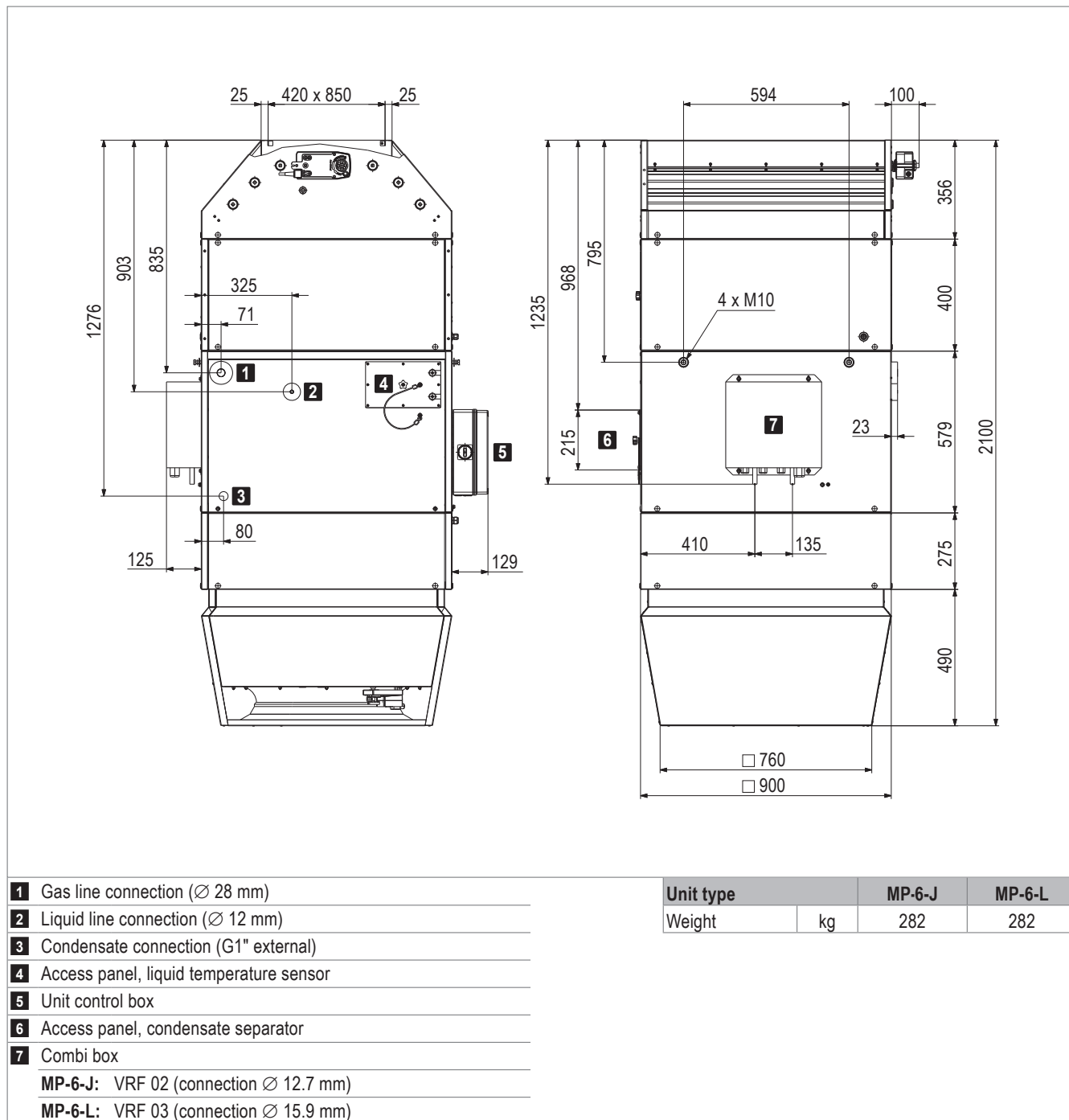
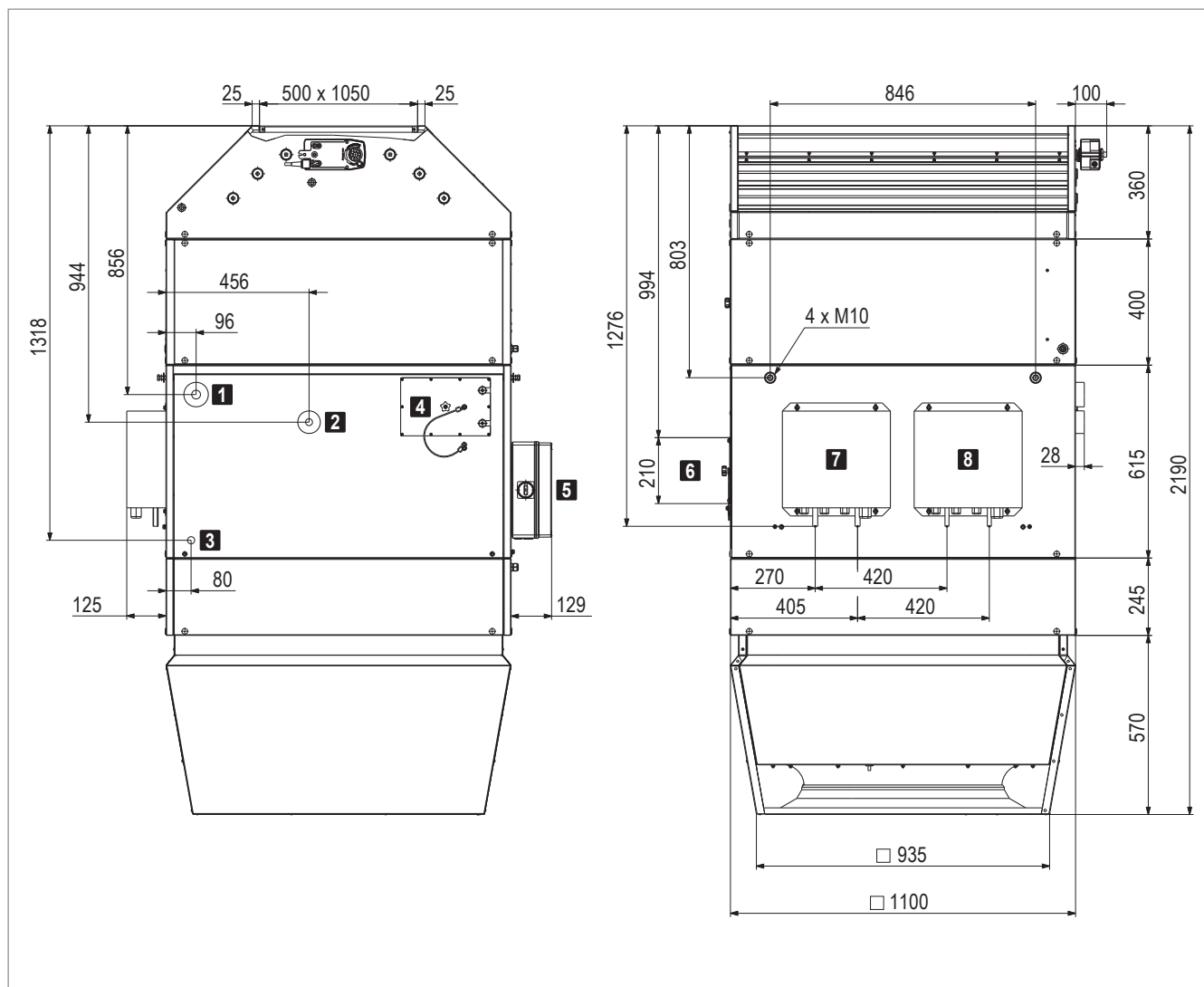

Fig. 9: Dimensions and weights TopVent® MP-6

TopVent® MP-9



- 1 Gas line connection (∅ 28 mm)
- 2 Liquid line connection (∅ 22 mm)
- 3 Condensate connection (G1" external)
- 4 Access panel, liquid temperature sensor
- 5 Unit control box
- 6 Access panel, condensate separator
- 7 Combi box VRF 02 (connection ∅ 12.7 mm) – client
- 8 Combi box VRF 03 (connection ∅ 15.9 mm) – server

Unit type		MP-9-N
Weight	kg	380

Fig. 10: Dimensions and weights TopVent® MP-9

Belaria® VRF (33, 40)

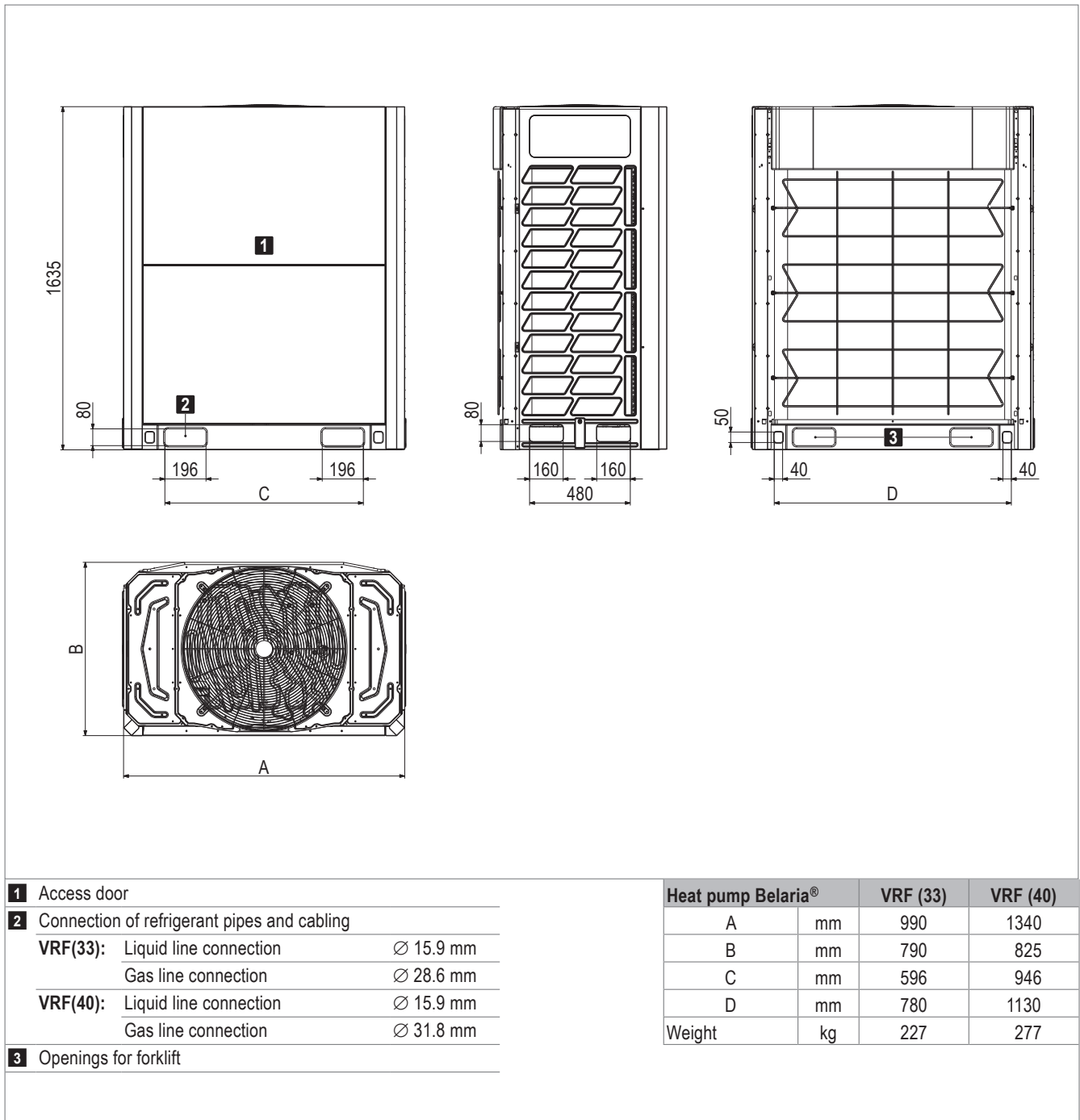

Fig. 11: Dimensions and weights Belaria® VRF (33, 40)

Belaria® VRF (67)

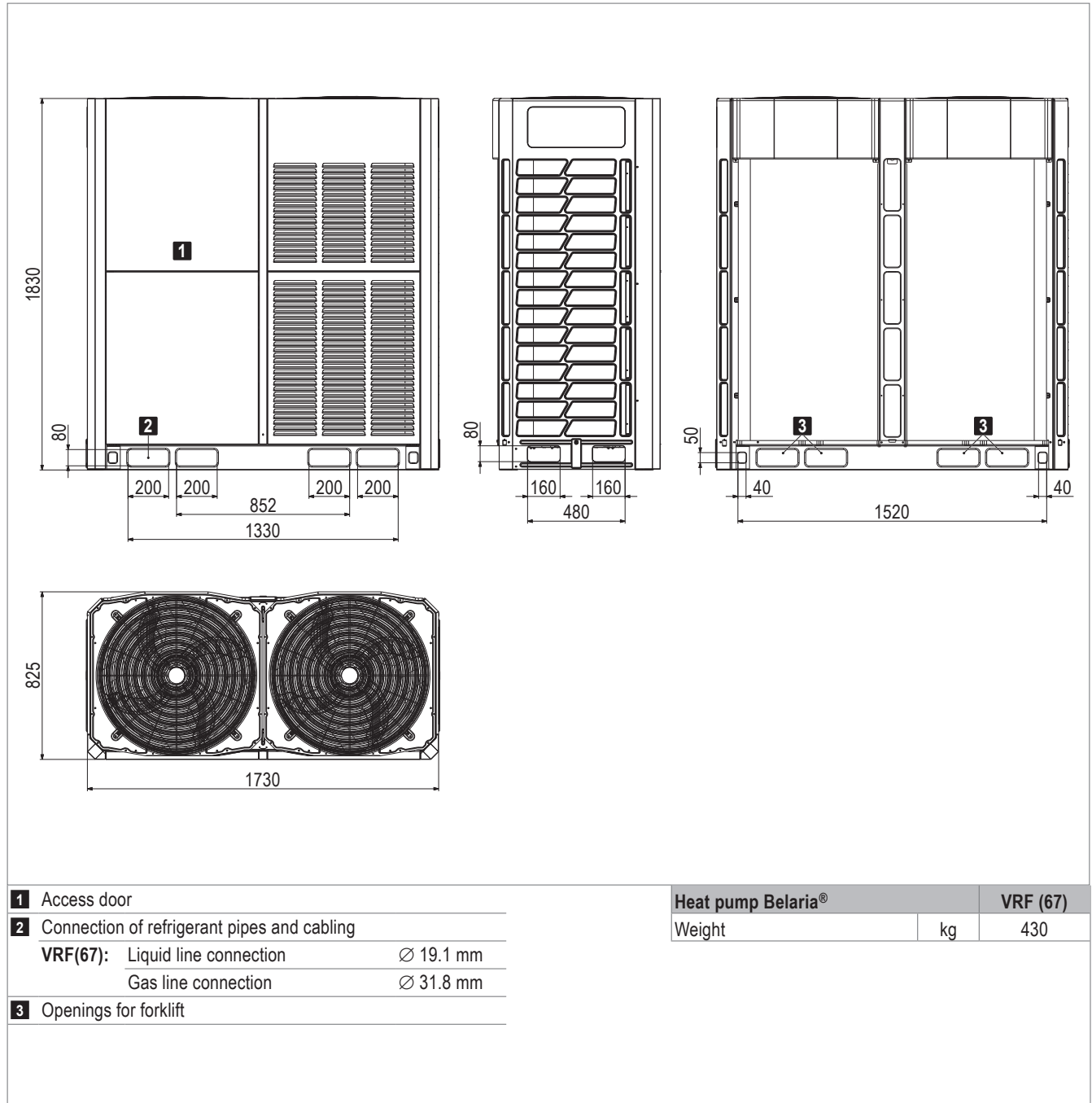

Fig. 12: Dimensions and weights Belaria® VRF (67)

6 Options

6.1 Suspension set

A suspension set is available to make it easy to install the units on the ceiling. The set consists of 4 pairs of U-profiles made of magnesium zinc sheet and is height-adjustable up to 1300 mm.

6.2 Air filtration

Filter box

A filter box with 2 bag filters can be installed for the purpose of filtering the recirculation air. The modular construction made of magnesium zinc sheet with 2 sliding doors makes it easy to replace the filters.

A pressure difference control device is installed for automatic monitoring of the filter. It shows when the filters have to be changed.

Size		6	9
A	mm	900	1100
B	mm	400	400
Filter class		ISO coarse 60 % (G4)	
Weight	kg	20	24
Factory setting of differential pressure switches	Pa	180	180

Table 19: Filter box technical data

Flat filter box

A flat filter box with 4 pleated cell filters can be installed for the purpose of filtering the recirculation air.

A pressure difference control device is installed for automatic monitoring of the filter. It shows when the filters have to be changed.

Size		6	9
A	mm	900	1100
B	mm	140	165
Filter class		ISO coarse 60 % (G4)	
Weight	kg	10	12.5
Factory setting of differential pressure switches	Pa	180	180

Table 20: Flat filter box technical data

6.3 Paint finish

If the customer wishes, the units can be provided with an exterior paint finish.

6.4 Recirculation silencer

The recirculation silencer is mounted on the appliance and thus reduces the sound reflection from the ceiling. Insertion attenuation is 3 dB compared with the total sound power level of each TopVent® unit.

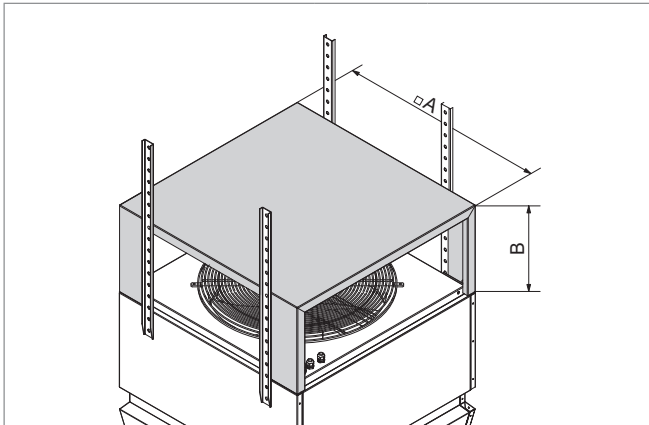

Size		6	9
A	mm	900	1100
B	mm	380	485
Weight	kg	15	20

Table 21: Recirculation silencer dimensions and weights

6.5 Condensate pump

The condensate pump is installed directly under the condensate drain connection; the supplied container is prepared for installation on the unit. It pumps the condensate through a flexible hose to a delivery head of 3 m, thus enabling discharge of the condensate

- through waste water pipes directly below the ceiling,
- onto the roof.

6.6 Options for the heat pump

Protection hood

To protect the heat pump from strong winds and snowfall, protection hoods are available as accessories. They are supplied loose with the appropriate connecting screws for assembly on site.

7 Transport and installation



Caution

Risk of injury from incorrect handling. Transport, assembly and installation work may only be performed by specialists. Observe safety and accident prevention regulations.

7.1 Scope of delivery

The scope of delivery includes:

- TopVent® unit
- Heat pump Belaria® VRF
- Accessories
- Optional components
- Zone control panel

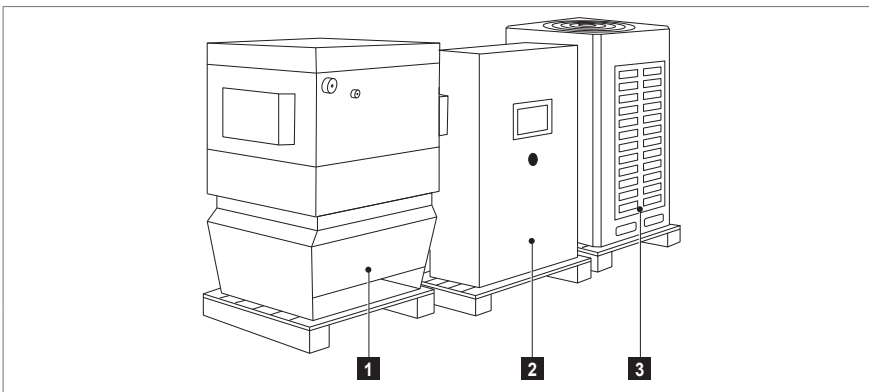

- | | |
|---|------------------------|
| 1 | TopVent® unit |
| 2 | Zone control panel |
| 3 | Heat pump Belaria® VRF |

Fig. 13: Delivery of the components on pallets

Accessories

The following accessories are supplied separately:

- Trap (in separate cardboard box)
- Fresh air temperature sensor and room air temperature sensor (in the zone control panel)
- Gas temperature sensor (in separate cardboard box)
- Branching kit for the refrigerant pipe (in separate cardboard box, only for size 9)

Options

The following optional components are supplied separately:

- Condensate pump (in separate cardboard box)
- Additional room temperature sensors, combination sensor room air quality, temperature and humidity (in zone control panel)
- Options for the heat pump:
 - Protection hoods (on separate pallet)

Preparation

- Use a forklift with a sufficiently long fork to unload (at least 1.8 m).
- Check the consignment against the delivery documents and the order confirmation to ensure that it is complete. Report missing parts and any damage immediately in writing.

Heat pump Belaria® VRF

- Lifting the heat pump with a forklift:
 - Lift the unit under the pallet.
 - Unloading from the pallet: Guide the forklift tines into the large rectangular openings under the device.
- Lifting the heat pump with a crane:
 - Use 2 straps at least 8 m in length.

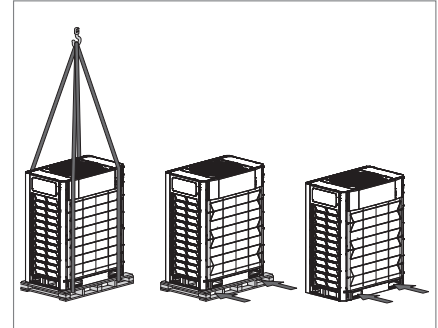

Fig. 14: Lifting the heat pump

7.2 Storage

If you do not install the unit immediately:

- Remove the packaging film to avoid water vapour condensation.
- Store the unit in a dry, dust-free room.
- Keep the storage temperature between -30°C and $+50^{\circ}\text{C}$.
- Avoid too long storage periods. After a storage period of more than 1 year:
 - Check that the bearings of the fans move smoothly before installing the unit.

7.3 Requirements for the installation site

TopVent® unit

- Comply with the minimum and maximum distances.
- Only secure the unit to ceilings with sufficient load-bearing capacity.
- All air inlet and air outlet openings must be freely accessible. The supply air jet must be free to spread out unhindered.
- The access panels in the unit must be freely accessible.
- Clearance of at least 0.9 m is required for maintenance work around the heating/cooling section.
- Make sure that supply air units draw in fresh air via the fresh air duct:
 - intake opening at approx. 1.5 m height above the roof
 - Not impaired by exhaust air openings, flues or the like

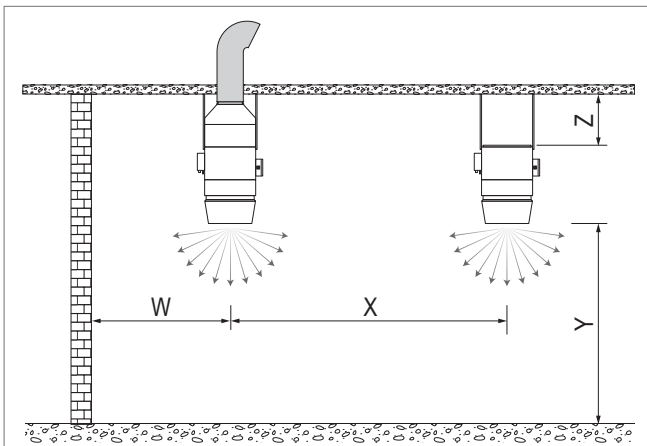

Unit type			TP-6	TP-9	MP-6	MP-9
Distance from ceiling Z	min.	m	0.3	0.4	0.3	0.4
Mounting height Y	max. ¹⁾	m	ca. 9...25			
	min.	m	4	5	4	5
Applications with higher comfort requirements						
■ Distance from wall W	max.	m	12	15	12	15
	min.	m	6	7	6	7
■ Unit clearance X	max.	m	23	31	23	31
	min.	m	12	14	12	14
Applications with low comfort requirements						
■ Distance from wall W	max.	m	15	20	–	–
	min.	m	6	7	–	–
■ Unit clearance X	max.	m	30	41	–	–
	min.	m	12	14	–	–

1) The maximum mounting height varies depending on the boundary conditions (for values, see table of heat outputs or calculation with the 'HK-Select' selection program)

Table 22: Minimum and maximum distances

Heat pump Belaria® VRF

- Place the heat pump as close as possible to the indoor climate unit, in a well ventilated location.



Notice

Excessively long refrigerant lines reduce the efficiency of the system. Place the heat pump as close as possible to the indoor climate unit.

- Note the following when choosing a location:
 - Not in potentially explosive atmospheres
 - Not in the vicinity of machines emitting electromagnetic waves
 - Not in locations where there is a fire hazard due to the escape of flammable gases
 - Not near a heat source with high temperature
 - Not in locations where dust or dirt can affect the heat exchangers
 - Not in locations with mineral oil vapours in the air
 - Not in locations with acidic or alkaline vapours in the air
 - Not in locations with a high salt content in the air



Caution

Risk of damage to health. Corrosion of refrigerant pipes causes leaks and refrigerant can escape.

- Observe the minimum distances for sufficient air flow through the heat pump.



Notice

If protection hoods are mounted, proportionally more space is required for good accessibility during maintenance work.

- Place the heat pump on a solid base with sufficient load-bearing capacity to avoid vibrations and noise.
- Install the heat pump on a solid base made of concrete or steel:
 - The base must be at least 200 mm high to allow sufficient space for the installation of the pipelines.
 - The base must be flat and level. The support points must bear the weight evenly.
 - Water must be free to drain through the base plate of the heat pump.
- In areas with heavy snowfall:
 - Increase the base height to ensure that the unit operation is not affected by snow.
 - Protect the heat pump with protection hoods (option).

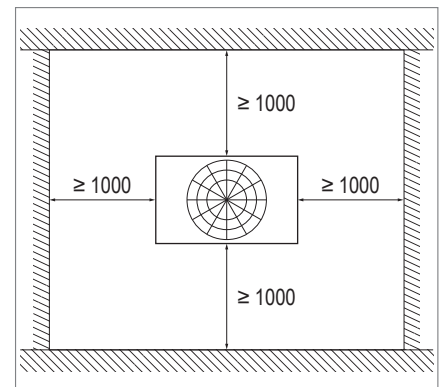

Fig. 15: Minimum distances for the heat pump (dimensions in mm)

7.4 Installing the heat pump

Caution
 Risk of injury caused by falling load and improper handling.
 During installation:

- Wear personal protective equipment.
- Do not stand under suspended loads.
- Use cranes or forklifts with sufficient load-bearing capacity.

- Transport the heat pump to the installation site.
- Drill holes for the expansion anchors in the prepared base (dimensions see Table 23).
- Mount the heat pump on the base using vibration dampers and 4 expansion anchors \varnothing 10 mm.

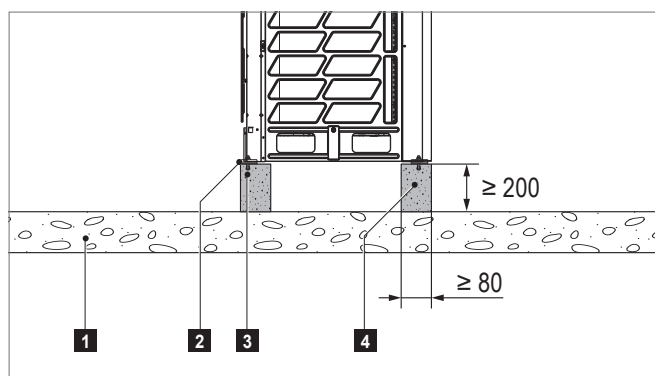

- 1** Firm ground
- 2** Vibration damper
- 3** Expansion anchor \varnothing 10 mm
- 4** Base made of concrete or steel

Fig. 16: Base for the heat pump

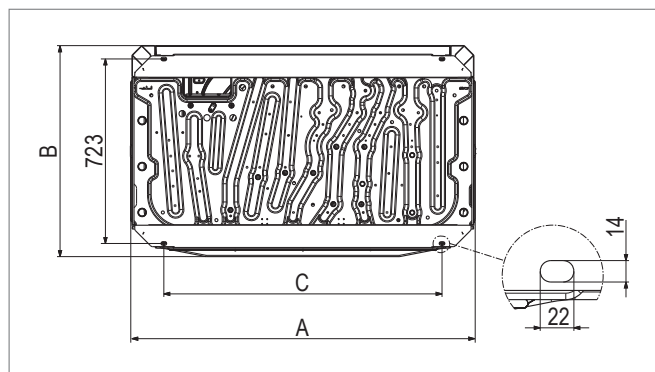

Dimension	VRF (33)	VRF (40)	VRF (67)
A	990	1340	1730
B	790	825	825
C	740	1090	1480

Table 23: Position of the screw connections (dimensions in mm)

Mounting the protection hoods

Protection hoods for the heat pump (option) are supplied loose, consisting of 2 side plates and 1 cover plate. They must be fitted to the unit at the building site. The mounting material is provided. Proceed as follows:

- Only for Belaria® VRF (67): Prepare the heat pump for the installation of the rear protection hoods.
 - Unscrew the protective grid.
 - Instead of the protective grid, screw the enclosed adapters to the heat pump with the same screws (see Fig. 17).

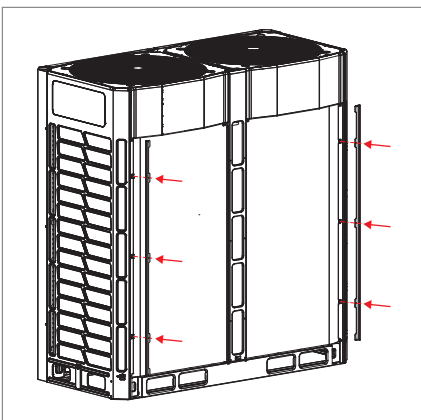

Fig. 17: Mounting the adapters

- Determine the correct position of the protection hood on the heat pump using dimensions E and F (see Fig. 19 and Table 24).
- Mark the position of the screws on the heat pump and pre-drill the holes with a $\varnothing 3.5$ mm drill.
 - Use the side plates as a template.
- Mount both side plates to the heat pump using the 4.2 x 13 drilling screws.
- Place the cover plate in position and fit it using the M4 x 10 screws.

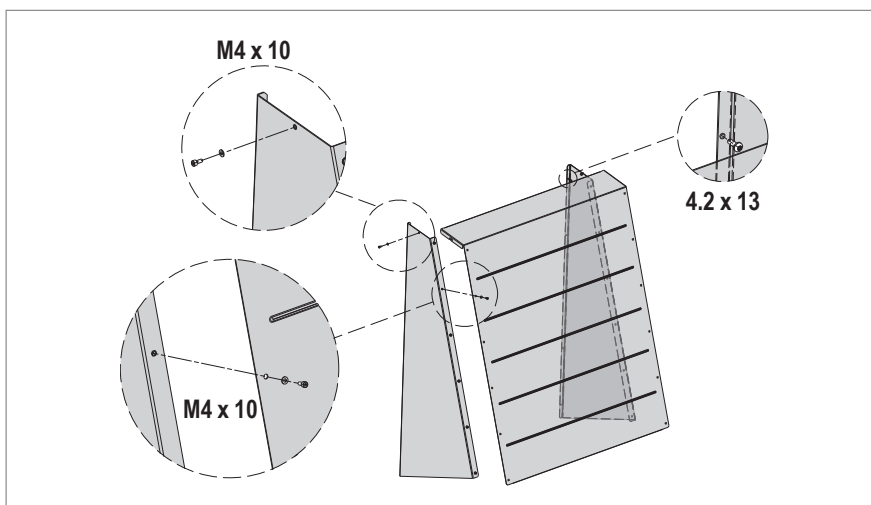

Fig. 18: Mounting the protection hoods

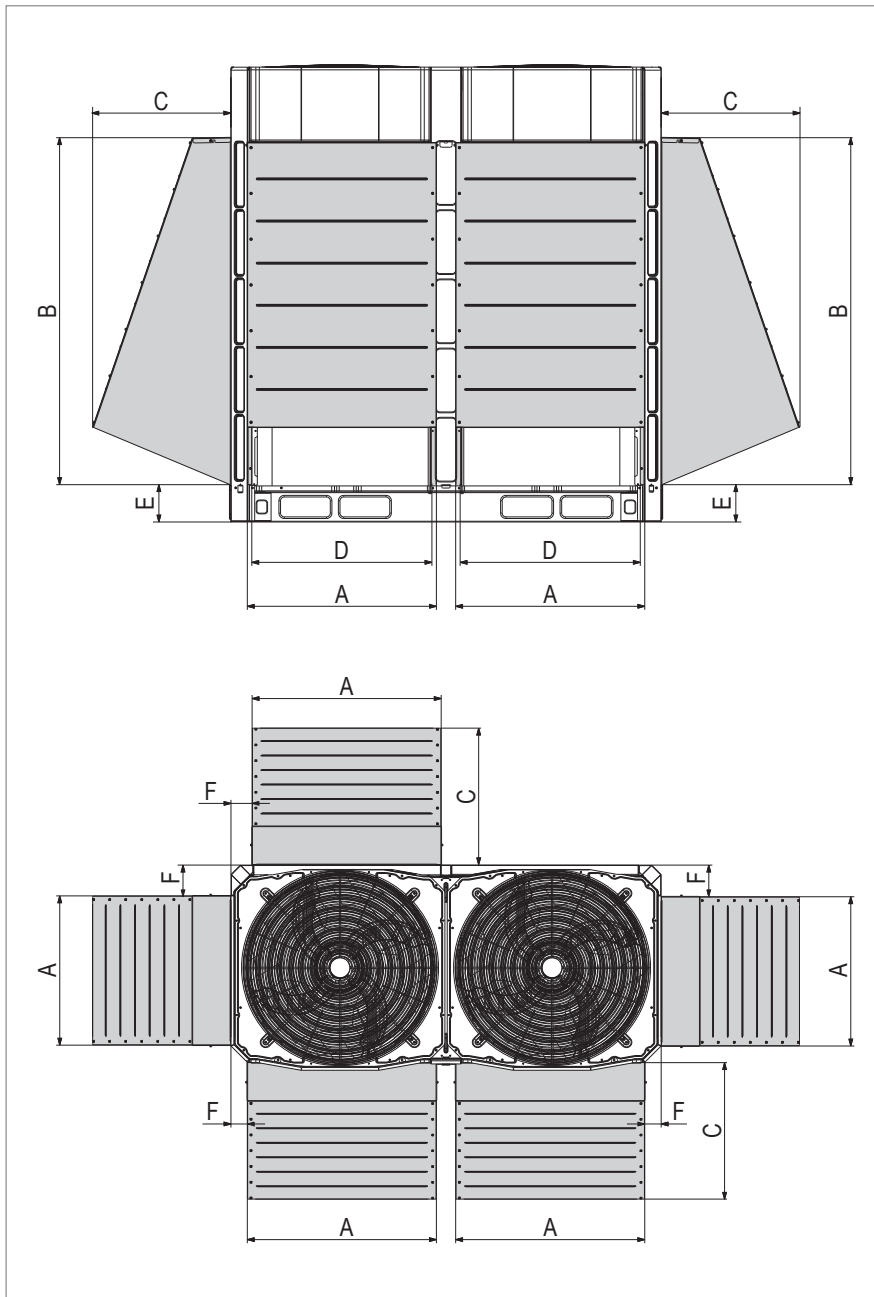
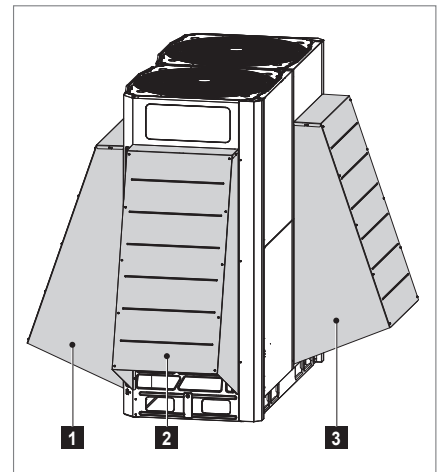

Fig. 19: Protection hoods dimensional drawing using the example of Belaria® VRF (67)



- 1** Rear protection hood
- 2** Side protection hood
- 3** Front protection hood

Fig. 20: Belaria® VRF (67) heat pump with protection hoods

Belaria®	Protection hood		Qty.	A	B	C	D	E	F
VRF (33)	Side	PS-33	2	578	1222	497	546	150	91
	Rear	PR-33	1	842	1222	497	810	154	75
VRF (40)	Side	PS-40	2	578	1222	497	546	150	91
	Rear	PR-40	1	1192	1222	497	1160	112	74
VRF (67)	Side	PS-67	2	600	1396	557	568	150	124
	Rear	PR-67	2	760	1378	550	724	150	66
	Front	PF-67	1	760	1378	550	724	150	85

Table 24: Quantity and dimensions of protections hoods (in mm)

7.5 Installing the TopVent® unit



Caution

Risk of injury caused by falling load and improper handling.

During installation:

- Wear personal protective equipment.
- Do not stand under suspended loads.
- Use cranes or forklifts with sufficient load-bearing capacity.

Preparation

- Make sure that a lifting platform is available.
- Remove the packaging film.
- For mounting, use the enclosed rivet nuts and
 - the optionally available suspension set or
 - flat irons, perforated irons, angle profiles, steel cables or similar

TopVent® installation

- Transport the unit to the installation site.
- Mount the suspension set on the designated suspension points.



Caution

Risk of injury from falling parts. Only fasten the unit at the designated suspension points. Do not place any suspension points on the optional components (filter box, recirculation silencer).

- Rotate the unit to the correct position (position of the refrigerant connections).
- Attach the unit to the ceiling.
- Install the device horizontally.
- Do not attach any additional loads.
- Do not use eyebolts.
- Non-vertical suspensions are permissible up to a maximum angle of 45°.
- TopVent® MP:
 - Connect supply air units to the fresh air duct via a canvas connection and connect both flanges with an earth wire.



Fig. 21: TopVent® TP installation

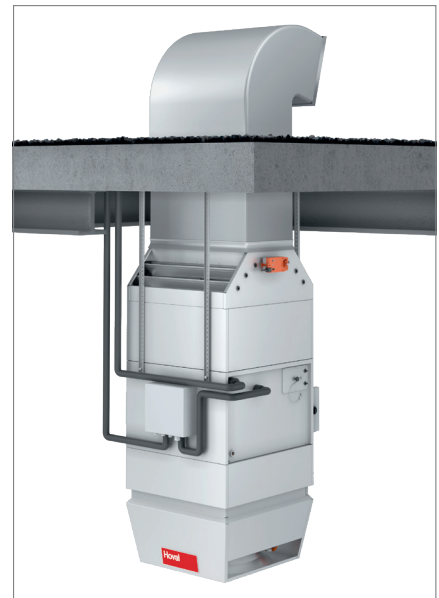

Fig. 22: TopVent® MP installation

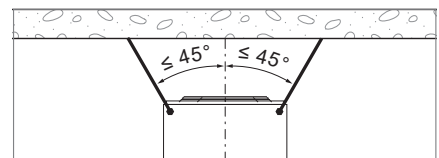

Fig. 23: Non-vertical suspension

7.6 Refrigeration system installation

The refrigerant pipes must be installed by a qualified refrigeration technician in line with the local regulations.

To avoid damaging the unit:

- Do not use any flux.
- Ensure there is a nitrogen supply when soldering.
- Protect the unit against excessive heat with a wet cloth.
- Insulate the refrigerant pipes with appropriate care.
- Carry out a leak-tightness test and vacuum drying.

Notes on installation

- Install the refrigerant pipes as shown in Fig. 30 to Fig. 32 schematically according to the local conditions. The maximum length for the flow and the return is 40 m each.
- The material to be used and the pipe thickness depend on the pipe diameter:

Pipe diameter	Material	Pipe thickness
∅ 12.7 mm	Hardened copper	0.8 mm
∅ 15.9 mm		1.0 mm
∅ 19.1 mm		1.0 mm
∅ 28.6 mm	Semi-hard copper	1.3 mm

Table 25: Configuration of refrigerant pipes

- The thickness of the insulation depends on the pipe diameter. Minimum thicknesses are given in Table 26. Thicker insulation is required in hot, humid environments.

Pipe diameter	Minimum thickness of the insulation ¹⁾	Material
∅ 12.7 mm	15 mm	Closed-cell foam, fire protection class B1, temperature-resistant up to 120 °C, outer insulation UV-resistant
∅ 15.9 mm	20 mm	
∅ 19.1 mm	20 mm	
∅ 28.6 mm	20 mm	

¹⁾ Increase the thickness of the insulation in hot, humid environments (> 80% relative humidity).

Table 26: Insulation of the refrigerant pipes

- Insulate the refrigerant pipes completely and without gaps.
- Insulate branch joints and weld seams only after the leak-tightness test.
- Insulate the liquid line and gas line separately.



Attention

Danger of unit damage due to condensation. Insulate the refrigerant pipes and connections with appropriate care to prevent condensation forming and dripping into the hall.



Fig. 24: Refrigerant pipes TopVent® TP-6

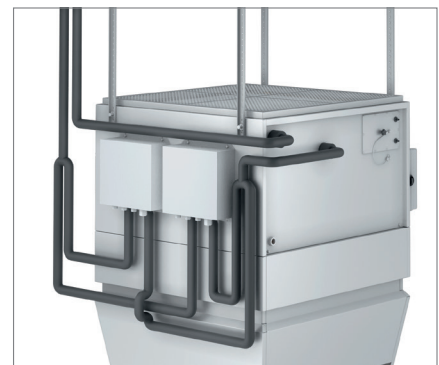
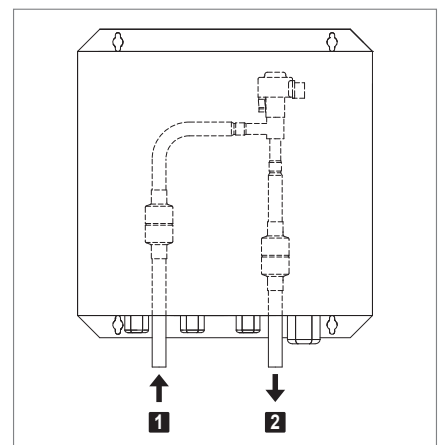

Fig. 25: Refrigerant pipes TopVent® TP-9



- 1** Refrigerant inlet (from the heat pump)
- 2** Refrigerant outlet (to the heating/cooling coil)

Fig. 26: Expansion valve in combi box

- 2 expansion valves are required for the Belaria® VRF (67). Use the branching kit supplied for branching the pipeline.
 - Install the branching kit so that the two branch pipes are in one plane.

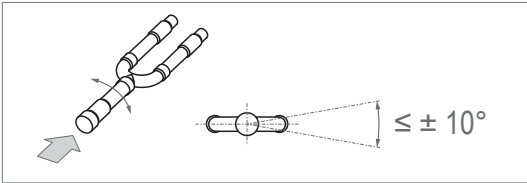

Fig. 27: Installation of the branching kit

- If the heat pump is placed more than 20 m higher than the heating/cooling coil: Install an oil return trap in the gas line every 10 m.

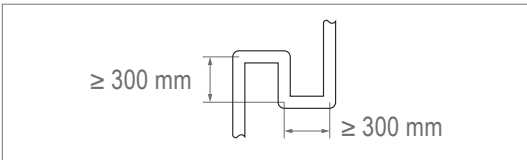
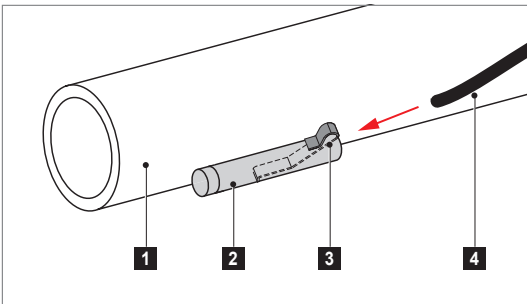

Fig. 28: Oil return trap

- Install the gas temperature sensor:
 - Solder the sleeve for the sensor to the gas line, as close as possible to the heating/cooling coil.
 - Use thermal paste to ensure a good conductivity between the sleeve and the gas line.
 - First insert the clamp and then the sensor into the sleeve.
 - Insulate the sensor and the gas line.
 - Bundle the cable up for subsequent connection to the connection box.



- 1 Gas line
- 2 Sleeve
- 3 Clamp
- 4 Gas temperature sensor

Fig. 29: Installing the gas temperature sensor

- Seal the refrigerant connections on the heating/cooling section:
 - Spray PU foam around the connections.
 - Apply the enclosed self-adhesive insulating mat around the connections.

Refrigerant pipes for Belaria® VRF (33)

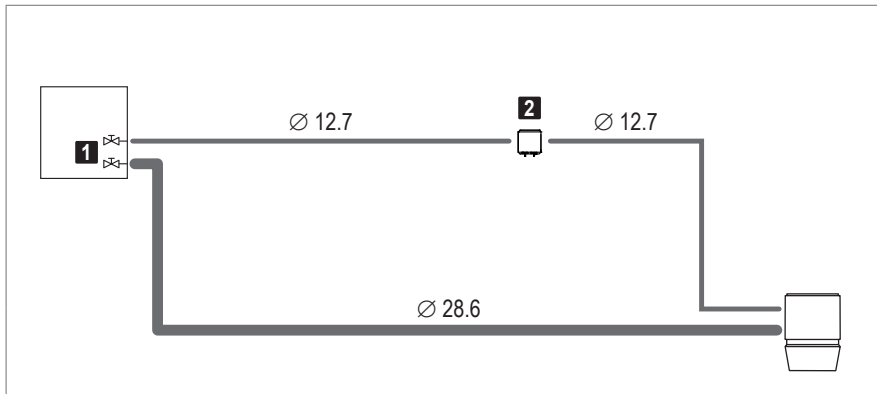

- 1** Connections on the heat pump
 - Liquid line Ø 15.9 mm
 - Gas line Ø 28.6 mm
- 2** Expansion valve in combi box VRF 02, mounted on the indoor climate unit

Fig. 30: Refrigerant pipes for Belaria® VRF (33) (pipe diameter in mm)

Refrigerant pipes for Belaria® VRF (40)

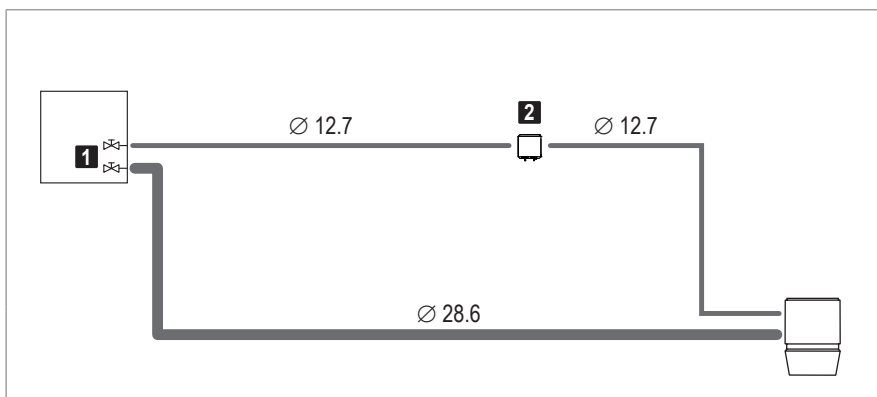

- 1** Connections on the heat pump
 - Liquid line Ø 15.9 mm
 - Gas line Ø 31.8 mm
- 2** Expansion valve in combi box VRF 03, mounted on the indoor climate unit

Fig. 31: Refrigerant pipes for Belaria® VRF (40) (pipe diameter in mm)

Refrigerant pipes for Belaria® VRF (67)

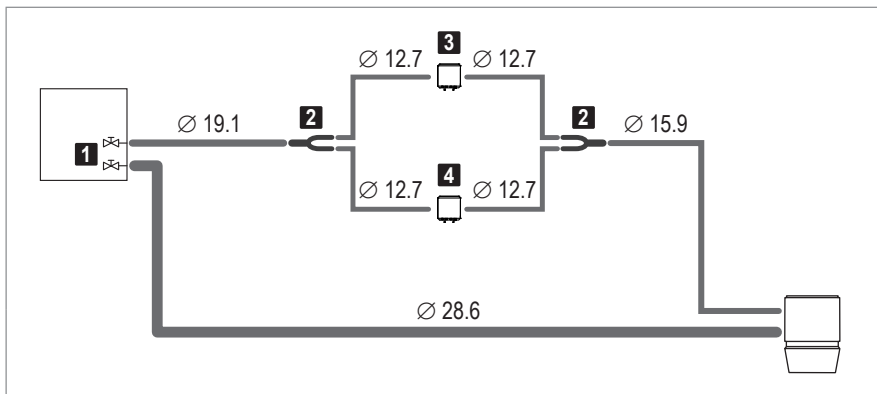

- 1** Connections on the heat pump
 - Liquid line Ø 19.1 mm
 - Gas line Ø 31.8 mm
- 2** Branching kit, supplied loose
- 3** Expansion valve in combi box VRF 02, mounted on the indoor climate unit
- 4** Expansion valve in combi box VRF 03, mounted on the indoor climate unit

Fig. 32: Refrigerant pipes for Belaria® VRF (67) (pipe diameter in mm)

Filling with refrigerant

- Carry out a leak-tightness test and vacuum drying before charging refrigerant.
- Calculate the additional refrigerant fill.
- Refrigerant R410A is a mixture. It is essential to add it in the liquid state. The composition can vary in the gaseous state.

Calculation of the additional refrigerant fill

- The heat pump is filled with refrigerant at the factory:
 - Refrigerant R410A
- Depending on the unit size, the heat pump is only partially prefilled at the factory, and so refrigerant must be added on site:

Belaria®		VRF (33)	VRF (40)	VRF (67)
Prefill volume	kg	11.0	11.8	11.8
Top-up volume	kg	–	1.2	10.2
Total fill volume	kg	11.0	13.0	22.0

- In addition, refrigerant must be topped up depending on the length and diameter of the liquid line (from the heat pump to the expansion valve).
 - Ø 12.7 mm . . . 0.11 kg refrigerant per metre length
 - Ø 19.1 mm . . . 0.26 kg refrigerant per metre length
- The entire top-up volume is calculated as follows:

Top-up volume of heat pump	=	_____
+ _____ m (Ø 12.7) × 0.11	=	_____
+ _____ m (Ø 19.1) × 0.26	=	_____
Total top-up volume	=	_____

7.7 Condensate connection TopVent®

Condensate arising in cooling units must be removed via a condensate-proof line.

- Install and insulate the supplied trap on the condensate connection of the unit.
- Dimension the slope and cross-section of the condensate line so that no condensate backflow takes place.
- Make sure that the condensate produced is drained in compliance with local regulations.

Condensate pump (option)

- Remove the transport locking device from the condensate pump.
- Install the condensate pump directly under the condensate drain connection; the supplied container is prepared for installation on the unit.
- Connect the condensate pump to a condensate-resistant waste water pipe. To do this, use a hose and attach it using a hose clamp or use a pipe with an inner diameter of 9 mm.
- Route the condensate line from the pump directly upwards.



Notice

This line must not exceed the delivery head of the pump:
– head of 3 m up to a condensate quantity of max. 150 l/h
– head of 4 m up to a condensate quantity of max. 70 l/h
Consider the condensate quantity expected in your application. (It can be calculated with the selection program HK-Select).

- Install an odour trap at the highest point.
- Route the line with a constant incline downwards and then vertically downwards, and if possible down to below the condensate pump. This will create a siphon effect and thus improve the effectiveness of the condensate pump.
- Make sure that the condensate produced is drained in compliance with local regulations.

7.8 Heat pump condensate connection

- Make sure that the heat pump is not damaged by pooling water or ice formation:
 - Make sure that water is free to drain through the bottom plate of the heat pump.

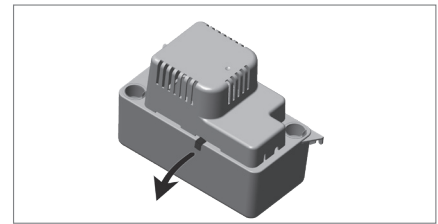

Fig. 33: Removal of the transport locking device

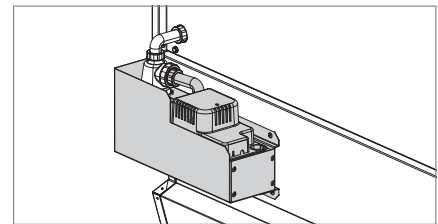

Fig. 34: Installation on the unit

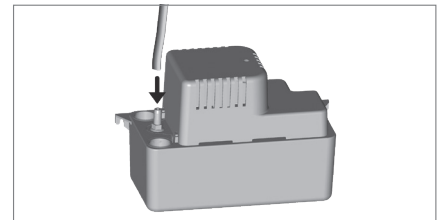

Fig. 35: Connection of the condensate pump

7.9 Electrical installation



Caution

Danger of electric shocks. The electrical installation must only be carried out by a qualified electrician.

Please note the following:

- Observe all relevant regulations (e.g. EN 60204-1).
- Choose the dimensions of the cable cross sections in line with the applicable regulations.
- Route signal and bus lines separately from mains cables.
- Make sure the lightning protection system for the units or for the entire building is planned and carried out by professionals.
- Provide overload protection equipment on site in the mains connection line of the zone control panel.
- Carry out the electrical installation according to the wiring diagram.
- Secure all connections against working loose.
- When installing cables, observe the following points:
 - Fasten the cables in place with cable mounts and cable ties or with cable conduits/ducts.
 - Use blind rivets.
 - Drill holes with a maximum diameter of 5 mm Ø.
 - The maximum drilling depth is 10 mm. Use a drill bit with a depth stop.
 - The maximum load resulting from cable holders and cable guides is 10 kg.
 - All access panels must be easily removable.

TopVent® unit

- Connect the power supply to the unit control box.
- Connect the zone bus to the unit control box.
- Connect the electrical components of the heat pump system (see Fig. 36 and Fig. 37).
- TopVent® MP:
 - Make sure that the ground cable is installed in the flange of the fresh air duct.

Temperature sensors

The room air sensor and the fresh air temperature sensor are supplied loose in the control panel:

- Install the room air temperature sensor at a representative position in the occupied area at a height of about 1.5 m. The measured values must not be distorted by the presence of sources of heat or cold (machines, direct sunlight, windows, doors, etc.).
- Install the fresh air temperature sensor at least 3 m above the ground on a north-facing wall, so that it is protected from direct sunlight. Provide cover for the sensor and thermally insulate it from the building.

TopVent® options

- Condensate pump:
 - Wire up the condensate pump to the unit control box.
- Forced off for TopVent® MP:
 - Wire up the signal for emergency shut-off (Forced off) to the unit control box.

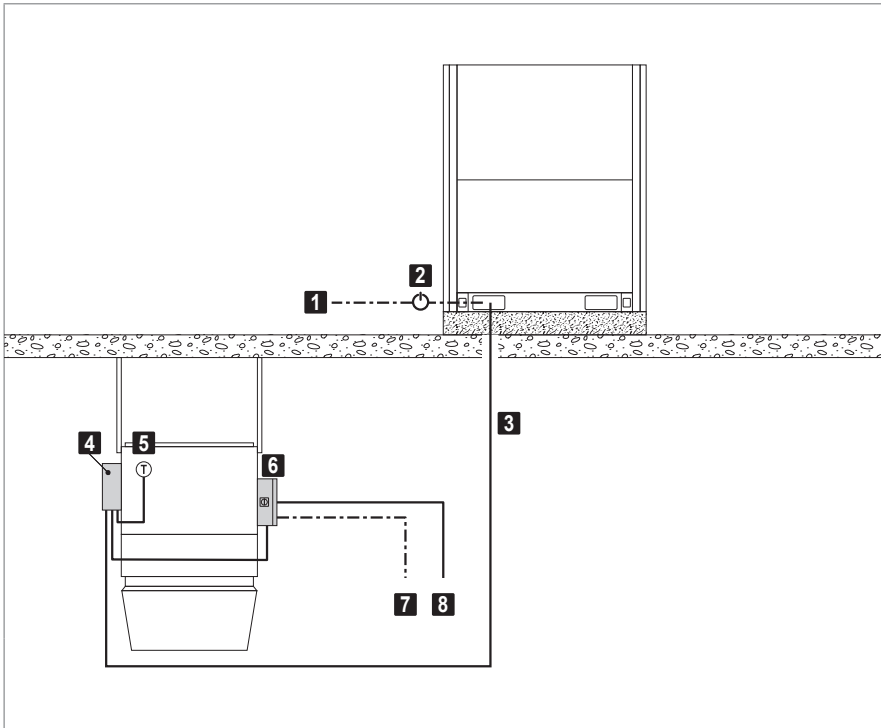

- 1** Power supply heat pump
- 2** Heat pump main switch (on-site)
- 3** Communication TopVent®
- 4** Combi box VRF
(conversion board, expansion valve)
- 5** Gas temperature sensor (supplied loose)
- 6** Unit control box
- 7** Power supply TopVent®
- 8** Zone bus

Fig. 36: Electrical connection of the heat pump system for TopVent® TP-6, MP-6

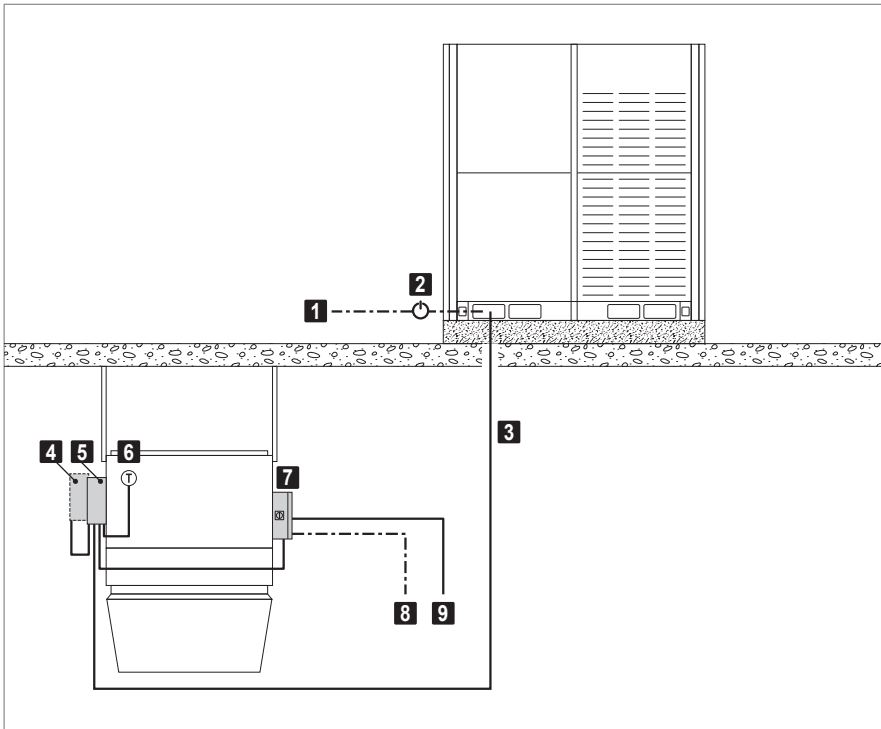

- 1** Power supply heat pump
- 2** Heat pump main switch (on-site)
- 3** Communication TopVent®
- 4** Combi box VRF 02 – client
(conversion board, expansion valve)
- 5** Combi box VRF 03 – server
(conversion board, expansion valve)
- 6** Gas temperature sensor (supplied loose)
- 7** Unit control box
- 8** Power supply TopVent®
- 9** Zone bus

Fig. 37: Electrical connection of the heat pump system for TopVent® TP-9, MP-9

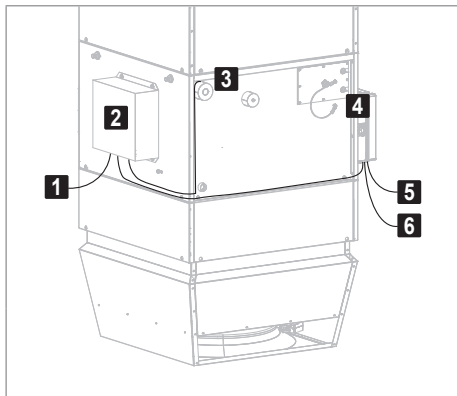

- | | |
|---|------------------------|
| 1 | Communication TopVent® |
| 2 | Combi box |
| 3 | Gas temperature sensor |
| 4 | Unit control box |
| 5 | Power supply TopVent® |
| 6 | Zone bus |

Fig. 38: Cable routing for TopVent® TP-6, MP-6

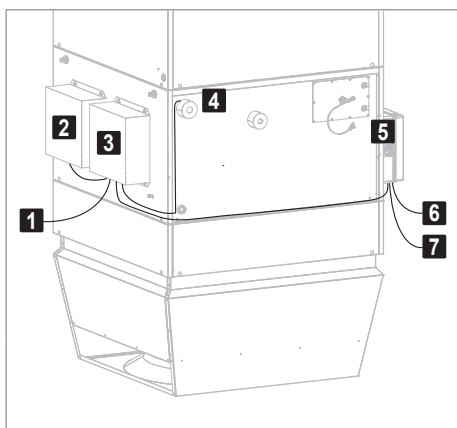

- | | |
|---|---------------------------|
| 1 | Communication TopVent® |
| 2 | Combi box VRF 02 – client |
| 3 | Combi box VRF 03 – server |
| 4 | Gas temperature sensor |
| 5 | Unit control box |
| 6 | Power supply TopVent® |
| 7 | Zone bus |

Fig. 39: Cable routing for TopVent® TP-9, MP-9

Heat pump Belaria® VRF

- Install a leakage current protective circuit for the heat pump power supply.
- Install a main switch in view of the heat pump.
- Connect the cable for the power supply to the main switch and from there route it to the connection terminals of the heat pump.
- Install the signal line:
 - Communication TopVent® (from the combi box to the heat pump)

8 Operation

8.1 Initial commissioning

**Attention**

Risk of damage to property as a result of performing initial commissioning on your own authority. Initial commissioning must be performed by the manufacturer's customer service technicians.

Checklist to prepare for commissioning:

- Mechanical installation
 - Indoor climate units
 - Heat pump system
 - Zone control panels
 - Operator terminals
- Refrigeration system installation
 - Heat pump system (filled and documented)
- Hydraulic installation
 - Indoor climate units (condensate connection)
- Electrical installation
 - Power supply for indoor climate units, heat pumps, zone control panels
 - Wiring of Air-Injector actuator, supply air temperature sensor, condensate pump, forced off and components of the heat pump system to the unit control box
 - Laying of bus cables conforming to wiring diagram
 - Installation and wiring of all sensors (room temperature sensor, fresh air sensor, ...)
 - Wiring of external operator terminals
 - Wiring of external inputs and outputs
- Organisational matters
 - Access to all system components during commissioning (indoor climate units, operator terminals, valves, ...)
 - Provision of a suitable working platform
 - Organisation of commissioning and training (date, presence of all of the respective trade groups and of the operating personnel)

The unit is checked at the factory and preset according to the specifications on the type label.

8.2 Operation

The system runs fully automatically depending on the programmed operating times and temperature conditions.

- Observe the operating instructions for the control system.
- Check alarm displays daily.
- Correct changes to operating times in the programming accordingly.
- Ensure free air outlet and unhindered dispersion of the supply air.

Information on the operating behaviour of the Belaria heat pump

Start-up at low room temperatures

At room temperatures between 5 °C and 12 °C	Time-delayed switching on of the fans of the ventilation unit because the heating/cooling coil is preheated first (duration approx. 5 to 10 min).
At room temperatures below 5 °C	No start of the heat pump possible. No commissioning possible.

Restart lock in fresh air operation

If the control system switches off the heat pump because no heat or cold is required (operating mode VE VEL AQ SA)	Restart lock of the heat pump for 7 min The restart lock prevents the heat pump from short cycling, thus extending the compressor's service life.
--	--

Very low fresh air temperatures

Fresh air temperature below -25 °C	Forced stop of the heat pump because the application limit has been reached. The ventilation unit switches to L_REC.
------------------------------------	--

Oil return

After 140 min operating time and then every 8 hours	The heat pump switches to cooling mode for oil return and signals a fault. The ventilation unit switches off. After completion of the oil return, the system switches back to the normal operating mode.
---	---

Restart lock after power failure

Power failure at fresh air temperatures below 4 °C	Restart lock of the heat pump to prevent cold start of a compressor. The ventilation unit switches to L_REC. The duration of the lock depends on the duration of the power failure and the fresh air temperature:	
	Power failure	Restart lock (at 4...-25°C fresh air temperature)
	5...30 min	10...120 min
> 30 min	60...480 min	

9 Maintenance and repair



Caution

Risk of injury from incorrect work. Maintenance work must be carried out by trained personnel.

9.1 Safety

Before performing any work on the unit:

- Turn the isolation switch on the unit to the 'Off' position and secure it against being switched back on.



Caution

Danger of electric shocks. The unit controller and the service socket are still live.

- Wait at least 3 minutes after switching the unit off.



Caution

The use of condensers can pose a danger of fatal injury from directly touching live parts even after the unit is switched off. Only open the unit after waiting 3 minutes.

- Observe the accident prevention regulations.
- Observe the particular dangers involved when working on electrical systems.
- When working in the unit, take precautions against unprotected, sharp metal edges.
- Immediately replace damaged or removed informational and warning signs.
- Following maintenance work, professionally reassemble all dismantled protective devices.
- Replacement parts must comply with the technical requirements of the unit manufacturer. Hoval recommends the use of original spare parts.

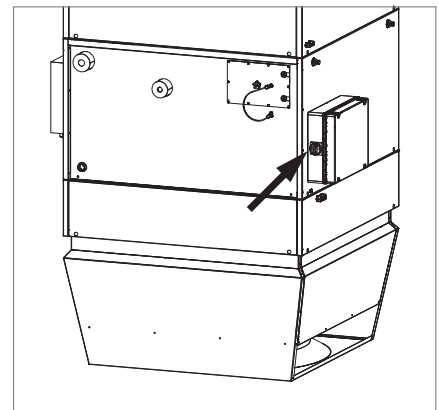

Fig. 40: Position of the isolation switch



Notice

The main switch for the heat pump is installed on site.

9.2 Maintenance

Maintenance schedule

Activity	Procedure	Interval															
Clean unit	<ul style="list-style-type: none"> ■ Clean the TopVent® unit and the Belaria® VRF heat pump. ■ Remove the siphon, clean it and rinse the condensate drain. 	1 × annually															
Functional check	<ul style="list-style-type: none"> ■ Check function of the fan and actuators. ■ Check function of the Air-Injector. ■ Check function of the heat pump. ■ Check function of the control system. 	1 × annually															
Changing the filter	<ul style="list-style-type: none"> ■ Renew air filter. <table border="1" data-bbox="466 779 1090 969"> <thead> <tr> <th>Filter set</th> <th>Use</th> <th>Mat. no.</th> </tr> </thead> <tbody> <tr> <td>TopVent® 6 FK</td> <td>MP-6, TP-6 with filter box</td> <td>6049725</td> </tr> <tr> <td>TopVent® 6 FF</td> <td>TP-6 with flat filter box</td> <td>6049726</td> </tr> <tr> <td>TopVent® 9 FK</td> <td>MP-9, TP-9 with filter box</td> <td>6049727</td> </tr> <tr> <td>TopVent® 9 FF</td> <td>TP-9 with flat filter box</td> <td>6049728</td> </tr> </tbody> </table>	Filter set	Use	Mat. no.	TopVent® 6 FK	MP-6, TP-6 with filter box	6049725	TopVent® 6 FF	TP-6 with flat filter box	6049726	TopVent® 9 FK	MP-9, TP-9 with filter box	6049727	TopVent® 9 FF	TP-9 with flat filter box	6049728	When the filter alarm is displayed, at least 1× annually
Filter set	Use	Mat. no.															
TopVent® 6 FK	MP-6, TP-6 with filter box	6049725															
TopVent® 6 FF	TP-6 with flat filter box	6049726															
TopVent® 9 FK	MP-9, TP-9 with filter box	6049727															
TopVent® 9 FF	TP-9 with flat filter box	6049728															

Table 27: Maintenance schedule

Changing the filter

- Changing the air filter in the filter box:
 - Open the sliding door of the filter box.
 - Loosen the adjusting screw.
 - Remove the filter elements.
 - Insert the new filter elements.
 - Tighten the adjusting screw.
 - Close the sliding door of the filter box.
- Changing the air filter in the flat filter box:
 - Remove the filter elements from above.
 - Insert the new filter elements.
 - For TopVent® TP with electric heating coil: Insert the high-temperature filter with the metal mesh facing down.
- Dispose of the filters in accordance with local regulations.
 - The disposal of used filters depends on the contents.

9.3 Repair

If required, contact Hoval customer service.

Product service life

Component	Service life
EC motors of the supply air and exhaust air fans	approx. 30'000 to 40'000 hours depending on the application and environmental conditions
Damper actuators with spring return	at least 60'000 emergency positions

Table 28: Product service life

10 Dismantling

**Caution**

Risk of injury caused by falling load and improper handling.

- Wear protective equipment (fall protection, helmet, safety shoes).
- Do not stand under suspended loads.
- Use cranes or helicopters with sufficient load-bearing capacity.
- Do not lift the two-part unit in one piece.

- Disconnect the power supply to the unit.
- Wait at least 3 minutes after switching the unit off.

**Caution**

The use of condensers can pose a danger of fatal injury from directly touching live parts even after the unit is switched off. Only open the unit after waiting 3 minutes.

- Drain the refrigerant circuit.
- Dismantle all media connections.
- Support the unit.
- Disconnect the unit from the ceiling.
- Remove the unit.

11 Disposal

- Recycle metal components.
- Recycle plastic parts.
- Dispose of electric and electronic parts via hazardous waste.
- Dispose of the filters in accordance with local regulations.
 - The disposal of used filters depends on the contents.

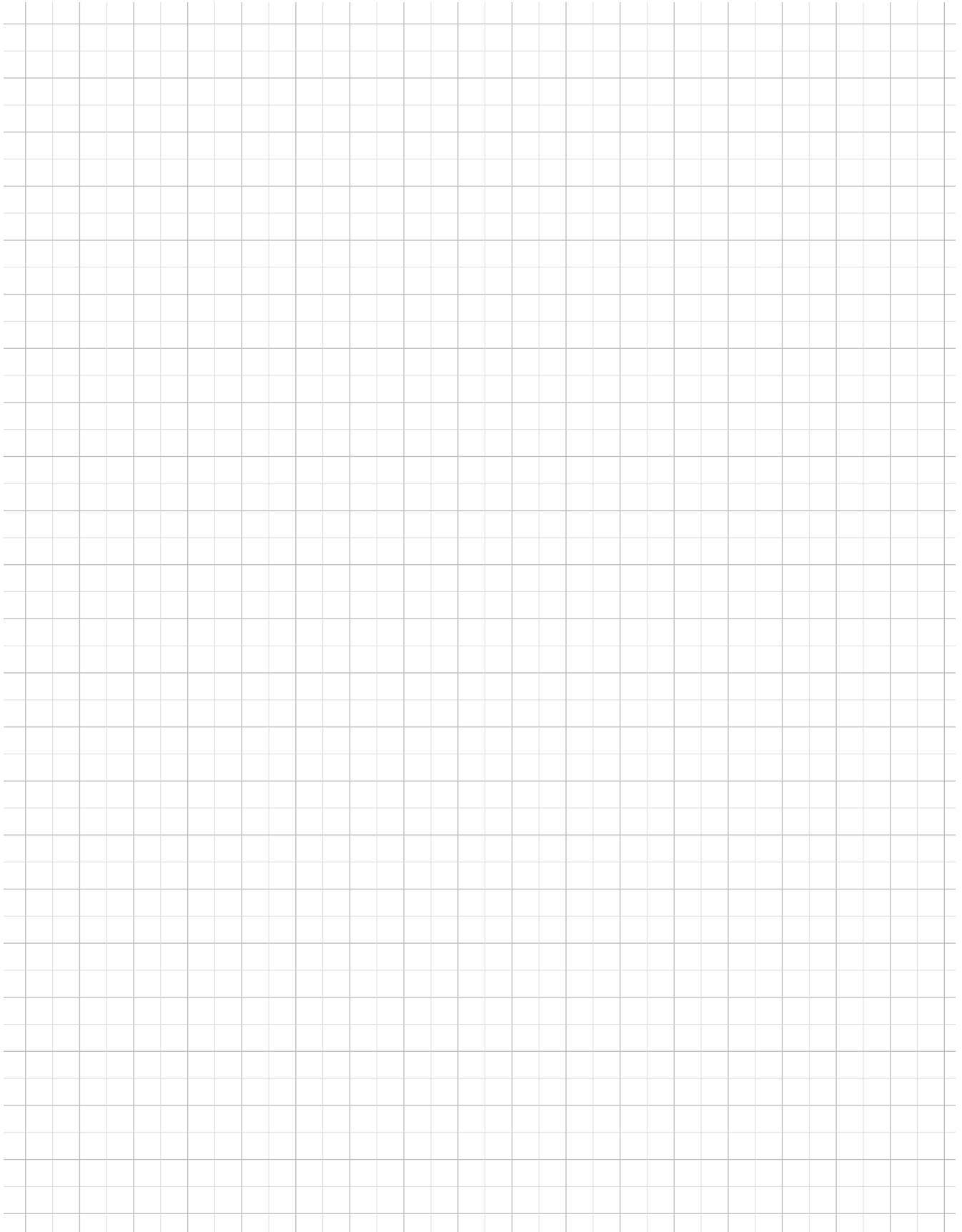

International

Hoval Aktiengesellschaft
9490 Vaduz
Liechtenstein
Tel. +423 399 24 00
info.klimatechnik@hoval.com
www.hoval.com

United Kingdom

Hoval Ltd.
Northgate, Newark
Notts
NG24 1JN
Tel. 01636 672711
hova1@hova1.co.uk
www.hova1.co.uk