

## Hoval Belaria<sup>®</sup> pro

Air/water heat pump  
Belaria<sup>®</sup> pro (40,50)

R290

Natural refrigerant!

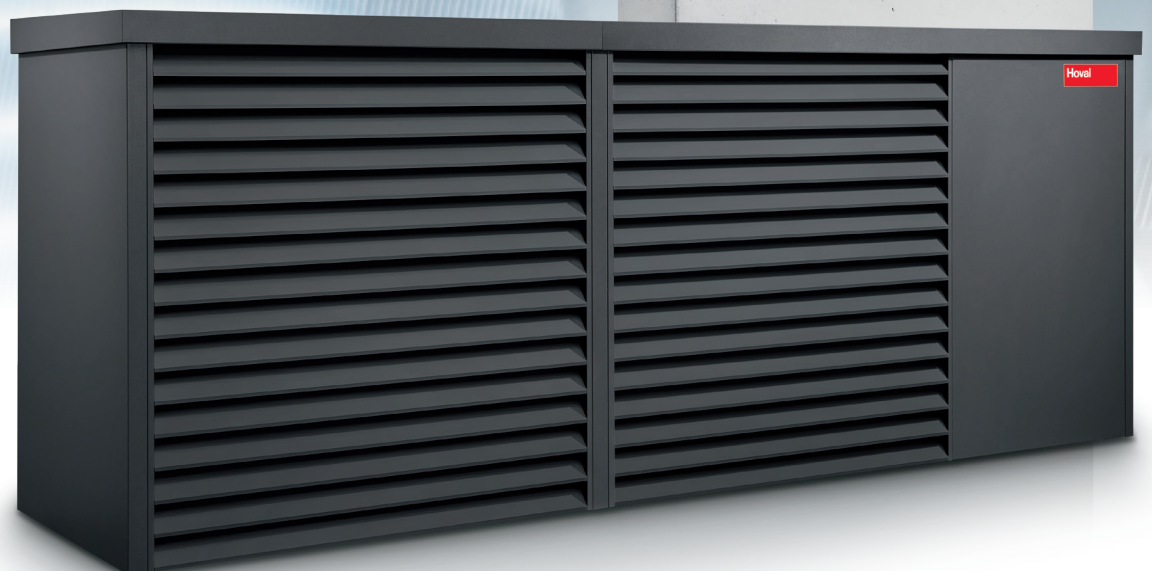



**Table of contents**

■ Description	5
■ Part numbers	7
■ Technical data	14
■ Dimensions	25
■ Engineering	33



**Hoval Belaria® pro**  
**Modulating monoblock heat pump for heating and cooling.**

Monoblock heat pump set up outdoors consisting of outdoor unit and electrical box.

*Belaria® pro outdoor unit*

- Compact floor-mounted air/water heat pump
- Elegant, extremely quiet and efficient outdoor unit
- Casing with sheet metal cladding, powder-coated, colour anthracite (DB703)
- Two completely separated cooling units with the refrigerant R290
- Integrated components:
  - 2 speed-controlled scroll compressors
  - 2 straight fin evaporators
  - 2 speed-controlled axial fans
  - 2 plate condensers made of stainless steel/copper
  - 2 built-in gas separators with safety valve 2.5 bar
  - 2 speed-controlled high-efficiency pumps
  - 2 flow rate sensors/heat meters
  - 2 condensate drip trays including tray heating and condensate heating tape for channelling all the condensate in the outdoor unit, fixed installation, 1" connection
  - integrated vibration-damping feet for effective structure-borne noise decoupling
- With cooling function with corresponding hydraulics
- Hydraulic connections behind louvre grille
  - Heating connections 2"
  - Filter ball valve installed in the heat pump return
- Electrical connections behind louvre grille
  - 400 V main power supply
  - 230 V control current, supplied from the electrical box
  - Data cable for bus connection to the electrical box
- With support rail for fixing the outdoor unit on the ground

*Belaria® pro electrical box*

- Compact wall-mounted electrical box
- Casing with sheet metal cladding, powder-coated, flame red (RAL 3000)
- TopTronic® E control installed with TopTronic® E control module
- With 2 WFA-200S automatic heat pump devices
- Integrated control functions for
  - 2 heating/cooling circuits with mixer
  - 2 heating/cooling circuits without mixer
  - 1 hot water charging circuit
  - bivalent and cascade management
- With control set (switching contactor) for activating an external electric heating element
- Electrical connections introduced from bottom
- With fitting accessories for fixing the electrical box to the wall (without screws)
- Maximum cascading: 4 Belaria® pro (40,50), since 2 TTE-WEZ are installed per unit



**Model range**

Belaria® pro type	Heat output <sup>1)</sup>		Cooling capacity <sup>1)</sup>	
	35 °C	55 °C	A-7W35 kW	A2W35 kW
(40)			11.9-35.4	11.8-38.4
(50)			11.9-44.2	11.8-48.0

A+++ → D    A+++ → D

Energy efficiency class of the compound system with control.

<sup>1)</sup> Modulation range

*TopTronic® E controller*

*Control panel*

- 4.3-inch colour touchscreen
- Heat generator blocking switch for interrupting operation
- Fault signalling lamp
- Mains isolator

*TopTronic® E control module*

- Simple, intuitive operating concept
- Display of the most important operating states
- Configurable start screen
- Operating mode selection
- Configurable day and week programmes
- Operation of all connected Hoval CAN bus modules
- Commissioning wizard
- Service and maintenance function
- Fault message management
- Analysis function
- Weather display (with HovalConnect option)
- Adaptation of the heating strategy based on the weather forecast (with HovalConnect option)

*TopTronic® E basic module heat generator TTE-WEZ*

- Integrated control functions for
  - 1 heating/cooling circuit with mixer
  - 1 heating/cooling circuit without mixer
  - 1 hot water charging circuit
  - bivalent and cascade management
- Outdoor sensor
- Immersion sensor (calorifier sensor)
- Contact sensor (flow temperature sensor)
- RAST 5 basic plug set

*Options for TopTronic® E controller*

- Can be expanded by max. 1 module expansion:
  - module expansion heating circuit or
  - module expansion Universal or
  - module expansion heat balancing
- Can be networked with up to 16 controller modules in total:
  - heating circuit/DHW module
  - solar module
  - buffer module
  - measuring module

*Number of additional modules that can be installed in the heat generator:*

- 1 module expansion and 1 controller module
- or**
- 2 controller modules

The supplementary plug set must be ordered in order to use expanded controller functions.

**For further information about the TopTronic® E, see “Controls”**

#### **EnergyManager PV smart**

Feature to increase self-generated power consumption in use with HovalConnect.

If a HovalConnect gateway is used together with the heat pump, the EnergyManager PV smart feature is available. This allows the heat pump to be operated preferentially at times of higher solar radiation. The feature uses online weather data on the current solar radiation for this purpose and can be adjusted by means of an associated threshold value. The self-consumption of electricity from an existing photovoltaic plant is thus increased and the purchase of grid electricity is reduced. This results in a lasting and significant cost-saving potential without further investment costs for the customer.

#### *Delivery*

- Outdoor unit and electrical box delivered packaged separately
- Sensor kit included loose in the electrical box:
  - outdoor sensor (AF)
  - calorifier sensor (SF1/SF1.1 and SF2/SF2.1)
  - flow sensor (VF1)
  - plant flow sensor heating (AVF H)
  - plant flow sensor calorifier (AVF W)

#### *On site*

- Wall ducts for hydraulic connection lines
- Hydraulic connection lines from the outdoor unit to the inside of the building
- Electrical connection line from the outdoor unit to the electrical box
- Strip foundation, floor plate

#### **Hoval Integrate**

For seamless integration into intelligent home automation and energy management systems. With Hoval Integrate, Hoval heat pumps with TopTronic® E control can be integrated into home automation and energy management systems via open, standardised interfaces. Predefined templates, plugins and Smart Grid integrations simplify implementation and enable intelligent decisions.

Functions such as PV surplus utilisation, dynamic electricity tariffs, grid-friendly control, load management or simple visualisations for analysis purposes can be created and operated individually.

System integrators are free to choose their desired system and benefit from broad compatibility and future-proof sector coupling.

Thanks to integrated building automation, end customers benefit from operating cost savings and cross-system functions.

Practical guide videos provide additional support for integration and commissioning – step by step and with a practical orientation.

#### **Notice**

Only available in Austria, Germany and Switzerland

**Air/water heat pump**



**Hoval Belaria® pro (40,50)**

Belaria® pro type	Heat output <sup>1)</sup>		Cooling capacity <sup>1)</sup>
	A-7W35 kW	A2W35 kW	A35W18 kW
(40)	11.9-35.4	11.8-38.4	13.0-41.8
(50)	11.9-44.2	11.8-48.0	13.0-41.8

<sup>1)</sup> Modulation range

**Part No.**

7019 608  
7019 609

**EnergyManager PV smart**

Feature to increase self-generated power consumption in use with HovalConnect.

**Further information**  
see "Description"

**Notice**

Only available in Austria, Germany and Switzerland

**Hoval Integrate**

For seamless integration into intelligent home automation and energy management systems

**Further information**  
see "Description"

**Further accessories can be found under the following rubrics:**

- Calorifiers/buffer storage tanks:
  - Calorifiers
  - Buffer storage tanks
  - Combination storage tanks
  - Electric heating elements
- Heating armature groups/heating distributors
- Various system components:
  - 2-way and 3-way valves
  - 3-way mixers
  - 2-way and 3-way ball valves
  - Motor drives and butterfly valves
  - Diaphragm pressure expansion tanks
  - Fittings
  - Plate heat exchangers
- Circulating pumps

**TopTronic® E module expansions**  
for TopTronic® E basic module heat generator

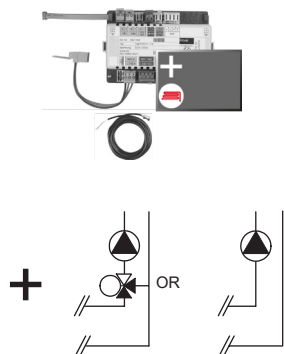

**TopTronic® E module expansion heating circuit TTE-FE HK**

Expansion to the inputs and outputs of the basic module heat generator or the heating circuit/domestic hot water module for implementing the following functions:

- 1 heating/cooling circuit without mixer or
- 1 heating/cooling circuit with mixer

Consisting of:

- Fitting accessories
- 1 contact sensor ALF/2P/4/T, L = 4.0 m
- Basic plug set FE module

**Notice**

The supplementary plug set may have to be ordered to implement functions differing from the standard!

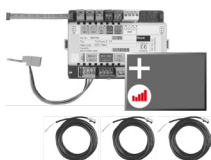

**TopTronic® E module expansion heating circuit incl. energy balancing TTE-FE HK-EBZ**

Expansion to the inputs and outputs of the basic module heat generator or the heating circuit/domestic hot water module for implementing the following functions:

- 1 heating/cooling circuit without mixer or
- 1 heating/cooling circuit with mixer incl. energy balancing in each case

Consisting of:

- Fitting accessories
- 3 contact sensors ALF/2P/4/T, L = 4.0 m
- Plug set FE module

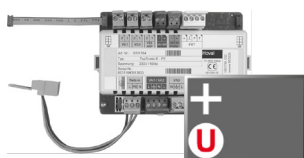

**TopTronic® E module expansion Universal TTE-FE UNI**

Expansion to the inputs and outputs of a controller module (basic module heat generator, heating circuit/domestic hot water module, solar module, buffer module) for implementing various functions

Consisting of:

- Fitting accessories
- Plug set FE module

**Further information**

see "Controls" section – "Hoval TopTronic® E module expansions" chapter

**Notice**

Refer to the Hoval System Technology to find which functions and hydraulic arrangements can be implemented.

**Part No.**

6034 576

6037 062

6034 575

Accessories for TopTronic® E



**TopTronic® E controller modules**

TTE-HK/WW	TopTronic® E heating circuit/ hot water module	6034 571
TTE-SOL	TopTronic® E solar module	6037 058
TTE-PS	TopTronic® E buffer module	6037 057
TTE-MWA	TopTronic® E measuring module	6034 574



**Supplementary plug set**

for basic module heat generator TTE-WEZ	6034 499
for controller modules and module expansion TTE-FE HK	6034 503



**TopTronic® E room control modules**

TTE-RBM	TopTronic® E room control modules	
	easy white	6037 071
	comfort white	6037 069
	comfort black	6037 070



**Enhanced language package TopTronic® E**

one SD card required per control module	6039 253
Consisting of the following languages:	
HU, CS, SL, RO, PL, TR, ES, HR, SR, JA, DA, NL	



**HovalConnect**

HovalConnect LAN	6049 496
HovalConnect WLAN	6049 498
HovalConnect Modbus	6049 501
HovalConnect KNX	6049 593

**TopTronic® E interface modules**

GLT module 0-10 V	6034 578
-------------------	----------

**TopTronic® E sensors**

AF/2P/K	Outdoor sensor	2055 889
	H x W x D = 80 x 50 x 28 mm	
TF/2P/5/6T	Immersion sensor, L = 5.0 m	2055 888
ALF/2P/4/T	Contact sensor, L = 4.0 m	2056 775
TF/1.1P/2.5S/6T	Collector sensor, L = 2.5 m	2056 776



**Bivalent switch**

for various release or switching functions	
Bivalent switch 1-piece	2056 858
Bivalent switch 2-piece	2061 826



**System casing**

System casing 182 mm	6038 551
System casing 254 mm	6038 552



**TopTronic® E wall casing**

WG-190	Wall casing small	6052 983
WG-360	Wall casing medium	6052 984
WG-360 BM	Wall casing medium with control module cut-out	6052 985
WG-510	Wall casing large	6052 986
WG-510 BM	Wall casing large with control module cut-out	6052 987



Further information  
see "Controls"

Accessories



**Switching ball valve VBI60.50-37L; PN 40**

Internal thread Rp 2"  
 Leakage rate: 0 ... 0.0001 % of kvs value  
 Permitted media: cold water,  
 cooling water, DHW, hot water,  
 water with frost protection  
 Recommendation:  
 water treatment according to VDI 2035  
 DN 50  
 kvs value: 37 m³/h  
 Medium temperature: -10 ... 120 °C  
 Ball valve body: brass  
 Ball: brass chrome-plated  
 Tappet: brass  
 Gland: EPDM O-rings

6052 447



**Motor drive GLB341.9E**

For straight-way ball valves VAG60.. and  
 switching ball valves VBI60.. DN 15-50  
 Operating voltage: 230 V, 50/60 Hz  
 Control signal 2-point/3-point  
 Single-wire/2 wire control  
 Operating time: 150 s  
 Nominal torque: 10 Nm  
 Permitted ambient temperature:  
 -32 ... 55 °C

2070 331



**Butterfly valve**

Without motor  
 Nominal pressure: PN 6-16

Connection size	$k_{vs}$ m³/h
DN 65	170
DN 80	260
DN 100	520
DN 125	880
DN 150	1400

2031 065  
 2031 066  
 2087 238  
 2087 246  
 2087 247

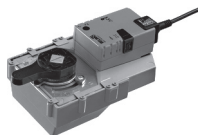

**Motor drives**

Control: 2-point (open-close)/partly 3-point  
 Nominal voltage: AC 100-240 V, 50/60 Hz

Type	Control	Nm	s
SR230A-R-5	2-/3-point	20	90
GR230A-5	2-point	40	150
DR230A-5	2-point	< 90	150
DR230A-7	2-point	< 90	150
PRCA-S2-T	2-/3-point	160	35

2044 276  
 2061 515  
 2087 248  
 2087 249  
 2082 322

Recommended use

	SR230A-R-5	GR230A-5	DR230A-5	DR230A7	PRCA-S2T
DN 65	•				
DN 80		•			
DN 100		•	•		
DN 125				•	
DN 150				•	•

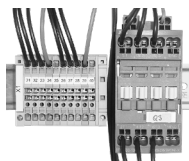

**Control set (switching contactor) for Belaria® pro (20-50)**

For activating an external electric heating element  
3~400 V / 50 Hz  
Control set for installation in the wall-mounted electrical box

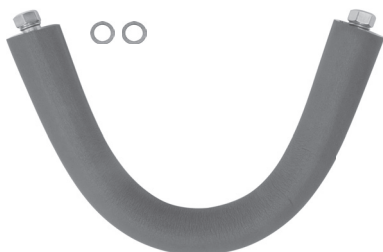

**Vibration decoupler**

for reducing structure-borne noise from heat pumps indoors, cannot be shortened  
Consisting of:

- 1 vibration decoupler insulated for heating and brine side flat-sealing with union nut
- 2 flat seals

Nominal pressure: PN 10

Dimension	Connection inches	Nominal length mm
DN 50	2"	500
DN 50	2"	1000

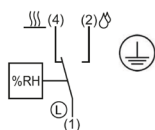

**Dewpoint monitor (TPW)**

for monitoring the formation of condensation in a compartment, with gold contacts, can be installed as required for pipes up to Ø 50 mm  
The installation location must be selected in such a way that a representative humidity measurement is guaranteed i.e. the room air must flow unhindered through the slots in the housing to the measuring element inside the casing.

The TPW does not require supply voltage or auxiliary energy and should be mounted in an air flow with an air velocity of at least 0.2 m/s.

Control range: 50 ... 90 % RH  
Max. switch power: 100 mA/250 V AC  
Operating temperature: 0 ... 60 °C  
Dimensions: 85 x 55 x 33 mm  
Weight: approx. 92 g  
Type of protection: IP20

**Part No.**

6063 944

2082 227

2080 800

2070 911

**Notice**

The dewpoint monitor is the only safety equipment in cooling systems and is always mandatory, to prevent damage caused by condensing water in surface cooling systems (floor, wall, ceiling cooling)!  
This applies to both active and passive cooling systems.

Separation system of heat pump



**Hoval system pump set SPS-I with interface for pump control with external thread including fittings**

Type	Nominal diameter DN	Delivery head mWC	Overall length mm	Integrated function <sup>1)</sup>	Connection inches	Rated pressure PN	≤ EEI
SPS-I	30	10	180	F02	G 2"	10	0.20

**Notice**

2 pumps are required

<sup>1)</sup> Type plate identification T  
F02 = 0-10 V, PWM1, PWM2



**XB61L-1-40 PN 25 G 2''**  
suitable for system separation  
Plate heat exchanger without seal  
made of stainless steel, brazed with  
copper solder under vacuum  
Design resistant to corrosion  
Calculation and materials according  
to the AD information sheets  
Produced according to DIN ISO 9001.  
CE-tested.  
Operating pressure: max. 25 bar  
Operating temperature: max. 180 °C  
Operating temperature: min. -10 °C  
Suitable for circulation water/  
water containing glycol with up to 50 %  
glycol proportion, ethylene glycol/  
propylene glycol-water mixtures,  
ethanol-water solutions and other  
suitable heat transfer fluids



**Bracket for XB61L-SB-1-30...60**  
for floor attachment  
Height: 217 mm  
Width: 300 mm  
Depth: 110 mm



**Insulation for: XB61 H: 30-90,  
M: 30-90, L: 30-50**  
made of mineral wool  
Conductivity: 0.029 W/mK  
Thickness: 30 mm  
Operating temperature: max. 160 °C

**Notice**

Not for cooling applications



**Set with 2 welding ends G 2'' E/DN 40 with union nuts and seals**  
suitable for the types:  
XB52 and XB61  
Diameter: 1½"  
Operating pressure: max. 25 bar  
Material: 1.0308

**Notice**

2 sets are required.

Part No.

6065 021

2080 135

2085 352

2080 129

2080 134

Services



**Services and associated scope of services**  
see separate catalogue "Hoval Services"

Commissioning by Hoval customer service is a prerequisite for warranty/guarantee activation.

Part No.

**Belaria® pro (40,50)**

Type		(40)	(50)
• Energy efficiency class of the compound system with control <sup>1)</sup> ( A+++ → D)	35 °C/55 °C	A+++/A+++	A+++/A+++
• Room heating energy efficiency "moderate climate" 35 °C η <sub>S</sub>	%	202	210
• Room heating energy efficiency "moderate climate" 55 °C η <sub>S</sub>	%	155	163
• Seasonal coefficient of performance moderate climate 35 °C/55 °C	SCOP	5.1/3.9	5.3/4.1
• Seasonal energy efficiency ratio A35W18 <sup>2)</sup>	SEER	5.7	5.7
• Seasonal energy efficiency ratio A35W7 <sup>2)</sup>	SEER	3.3	3.3
<b>Max./min. performance data heating and cooling in acc. with EN 14511</b>			
• Max. heat output A2W35	kW	38.4	48.0
• Max. heat output A-7W35	kW	35.4	44.2
• Min. heat output A15W35	kW	12.6	12.6
• Max. cooling capacity A35W18	kW	41.8	41.8
• Max. cooling capacity A35W7	kW	38.2	38.2
• Min. cooling capacity A35W18	kW	13.0	13.0
<b>Nominal output data heating in acc. with EN 14511</b>			
• Nominal heat output A2W35	kW	22.6	28.2
• Coefficient of performance A2W35	COP	5.1	4.4
• Nominal heat output A7W35	kW	23.2	32.1
• Coefficient of performance A7W35	COP	5.7	5.3
• Nominal heat output A-7W35	kW	27.7	37.1
• Coefficient of performance A-7W35	COP	3.6	3.2
<b>Nominal output data cooling in acc. with EN 14511</b>			
• Nominal cooling capacity A35W18	kW	35.8	35.8
• Energy efficiency ratio A35W18	EER	4.1	4.1
• Nominal cooling capacity A35W7	kW	25.0	25.0
• Energy efficiency ratio A35W7	EER	3.0	3.0
<b>Sound data</b>			
• Max. sound power level outdoor unit, day operation	dB(A)	65	65
• Sound power level EN 12102 outdoor unit whisper mode	dB(A)	59	59
• Sound power level EN 12102 outdoor unit <sup>3)</sup>	dB(A)	55	56
• Sound pressure level 5 m <sup>4)</sup>	dB(A)	36	37
• Sound pressure level 10 m <sup>4)</sup>	dB(A)	30	31
<b>Hydraulic data</b>			
• Max. flow temperature	°C	70	70
• Max. flow rate heating side with A7W35, ΔT 6 K	m <sup>3</sup> /h	6.3	7.9
• Nominal flow rate heating side with A7W35, ΔT 5 K	m <sup>3</sup> /h	5.1	5.7
• Max. flow rate heating side with A35W7, ΔT 4 K	m <sup>3</sup> /h	8.2	8.2
• Residual overpressure of heating pump at nominal flow A7W35, ΔT 5 K	kPa	57	46
• Residual overpressure of heating pump at max. flow rate A35W7, ΔT 4 K	kPa	37	37
• Max. operating pressure on the heating side <sup>5)</sup>	bar	2.5	2.5
• Flow/return connection heating	G	2"	2"
• Nominal air volume outdoor unit (A7W35 and nominal rotation speed)	m <sup>3</sup> /h	2 x 6600	2 x 6600
• Max. air volume outdoor unit (A7W35 and max. rotation speed)	m <sup>3</sup> /h	2 x 8000	2 x 8000
• Hydraulic connection line, max. length/dimension inside	m/DN	30/50	30/50

Type		(40)	(50)
<b>Cooling technical data</b>			
• Compressor		modulating	modulating
• Refrigerant		R290	R290
• Refrigerant filling quantity	kg	Circuit 1 = 4.8 Circuit 2 = 4.9	Circuit 1 = 4.8 Circuit 2 = 4.9
• Compressor oil type		PZ46M	PZ46M
• Compressor oil filling quantity	l	0.9	0.9
<b>Electrical data</b>			
• Electrical connection compressor	V/Hz	3~400/50	3~400/50
• Control electrical connection	V/Hz	1~230/50	1~230/50
• Electrical connection electric heating element	V/Hz	-	-
• Max. heat pump operating current	A	37.2	37.2
• Max. compressor operating current	A	2 x 18.2	2 x 18.2
• Max. fan operating current	A	2 x 0.3	2 x 0.3
• Max. operating current electric heating element	A	-	-
• Max. heat pump power consumption	kW	16.8	24.0
• Max. fan power consumption	W	2 x 194	2 x 194
• Max. starting current heat pump I <sub>A</sub>	A	37.0	37.0
• Output factor (cos φ)		0.88	0.88
• External protection main current	A	C/K 40	C/K 40
• External protection control current	A	B/Z 16	B/Z 16
• External protection electric heating element	A	-	-
• Fault-current circuit breaker		RCCB type B, I <sub>Δn</sub> ≥ 300 mA	
• Recommended cable		Cu 5 x 10.0 mm <sup>2</sup>	
• Nominal electrical output with A-7W35	kW	7.7	11.5
• Max. electrical output	kW	16.8 at A-18W60	24.0 at A-20W60
• Active power of heat pump	kW	20.0	20.0
• Max. operating voltage U <sub>b</sub>	V	3~400	3~400
• Max. operating current I <sub>b</sub>	A	37	37
• Max. inverter output current	A	2 x 24.0	2 x 24.0
• Pulse count		3	3
• Max. switching frequency per hour/day at t <sub>n</sub> 0 °C	n	3/72	3/72
• Continuous load changes			No
• Starting up under load			No
• Feedback into the power system			No
• Power factor correction			No
• Starting up assistance		Output control	
• Type of starting up assistance		Frequency converter	
• Frequency converter		60-360 Hz (20-120 rps)	
• Starting current/nominal current ratio		1.00	
<b>Dimensions/weight of outdoor unit</b>			
• Dimensions (H x W x D)	mm	1514 x 3750 x 1005	
• Weight	kg	1000	1000
• Protection class		IP24	IP24
<b>Dimensions/weight of electrical box</b>			
• Dimensions (H x W x D)	mm	750 x 600 x 160	
• Weight	kg	25	25
• Protection class		IP20	IP20

<sup>1)</sup> Related to moderate climate.

<sup>2)</sup> EN 14825

<sup>3)</sup> The sound values apply when the evaporator is clean. These values are temporarily exceeded before defrosting.

<sup>4)</sup> The sound pressure levels indicated apply if the outdoor unit is placed at a building façade. These values are reduced by 3 dB(A) if the outdoor unit is free-standing. With installation in a corner, the sound pressure level increases by 3 dB(A).

<sup>5)</sup> Maximum operating pressure of the system without isolating system 2.5 bar, as the outdoor unit is protected with 2.5 bar. Provide general protection of the system in the building with 3.0 bar. A system separation must be provided for system pressures of 2.5 bar or more.

Using a fault-current circuit breaker RCCB type B, I<sub>Δn</sub> ≥ 300 mA must be clarified based on the regulations of the country in question.

Diagrams of areas of application

Heating and domestic hot water

Belaria® pro (40,50)

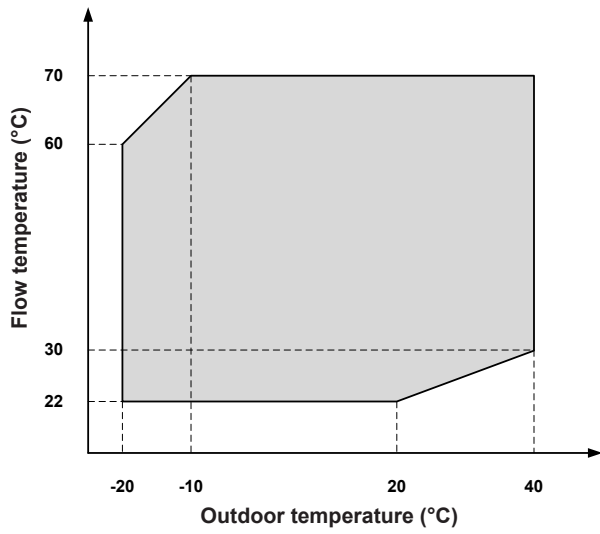

 Area of application of the heat pump for heating/domestic hot water

Cooling

Belaria® pro (40,50)

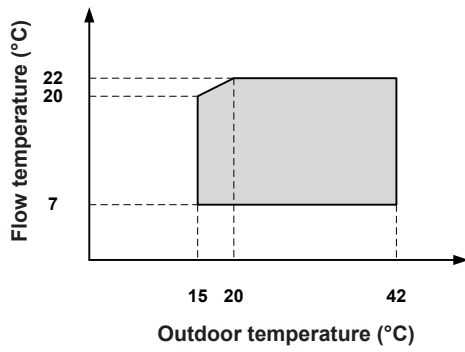

 Area of application of the heat pump for cooling

**Performance data – heating**

Maximum heat output allowing for defrosting losses

**Belaria® pro (40)**

Data according to EN 14511

**Heat output –  $t_{VL} 35\text{ °C}$**

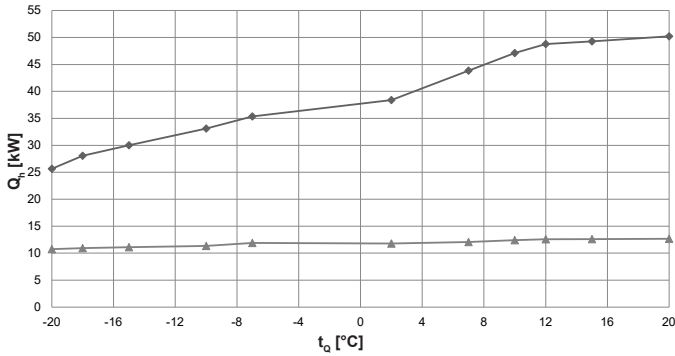

**Coefficient of performance –  $t_{VL} 35\text{ °C}$**

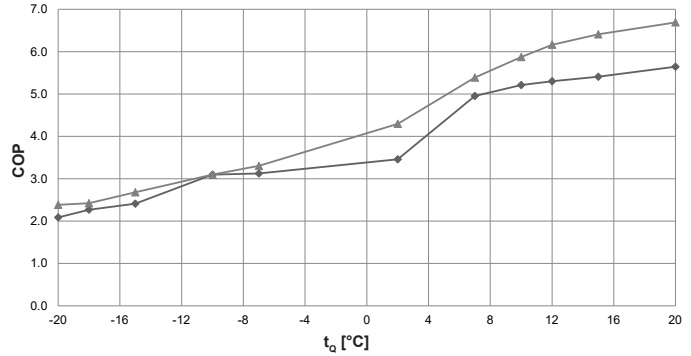

**Heat output –  $t_{VL} 45\text{ °C}$**

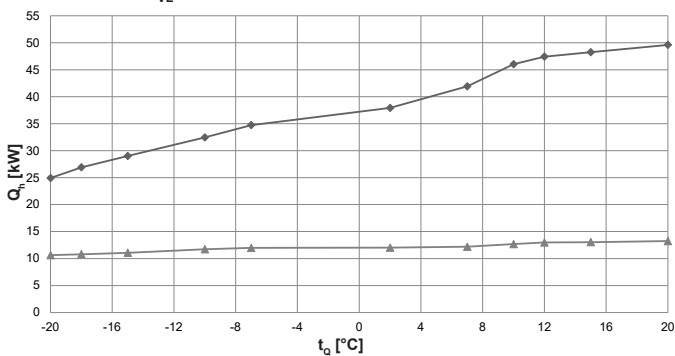

**Coefficient of performance –  $t_{VL} 45\text{ °C}$**

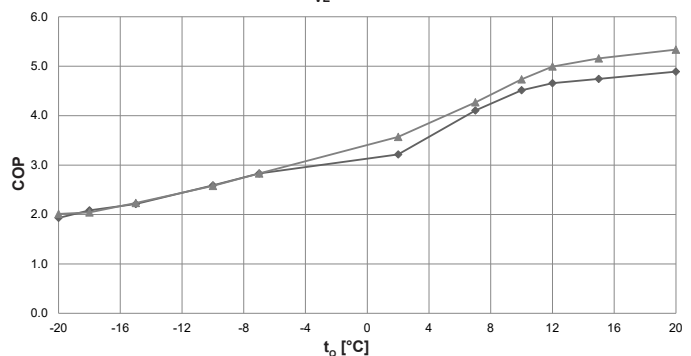

**Heat output –  $t_{VL} 55\text{ °C}$**

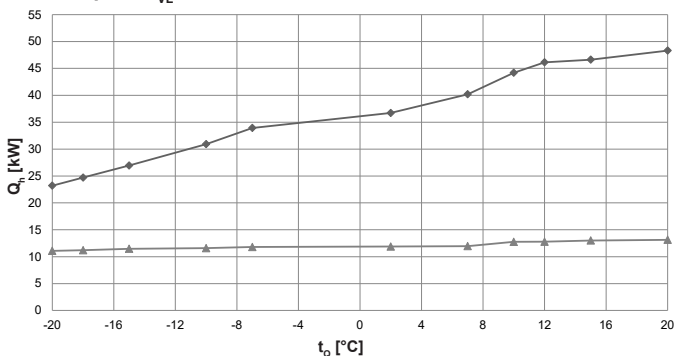

**Coefficient of performance –  $t_{VL} 55\text{ °C}$**

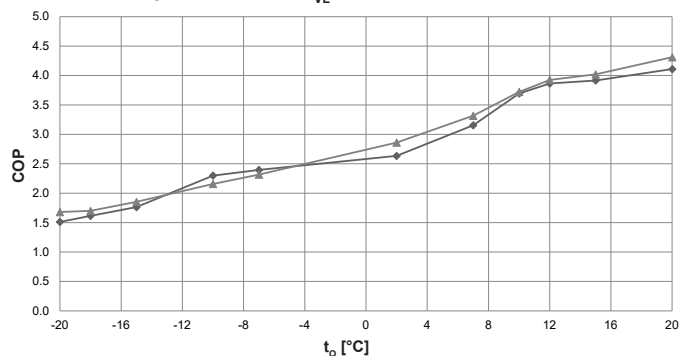

**Heat output –  $t_{VL} 70\text{ °C}$**

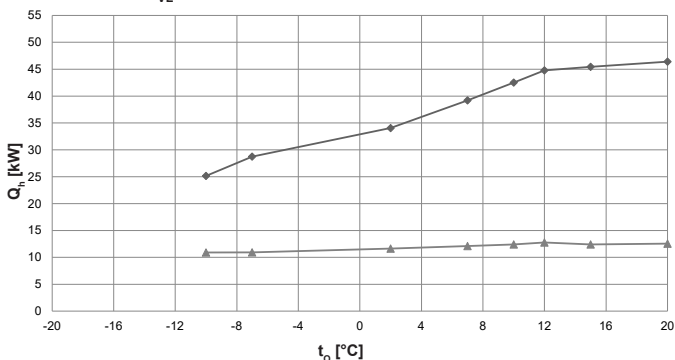

**Coefficient of performance –  $t_{VL} 70\text{ °C}$**

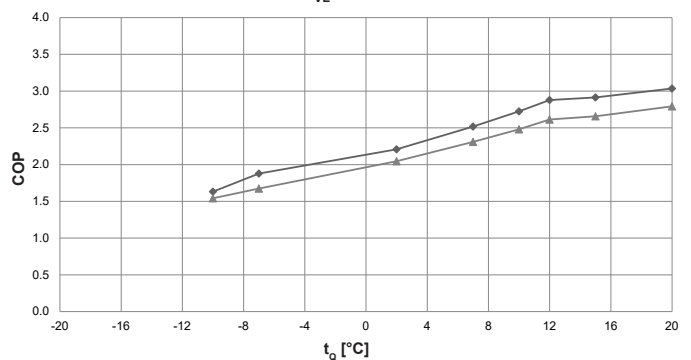

$t_{VL}$  = heating flow temperature (°C)

$t_O$  = source temperature (°C)

$Q_h$  = heat output (kW), measured in accordance with standard EN 14511

COP = Coefficient of Performance for the overall unit in accordance with standard EN 14511

◆ Maximum output

▲ Minimum output

Performance data – heating

Belaria® pro (40)

Data according to EN 14511

$t_{VL}$ °C	$t_o$ °C	Maximum output			Minimum output		
		$Q_h$ kW	P kW	COP	$Q_h$ kW	P kW	COP
35	-20	25.6	12.3	2.1	10.8	4.5	2.4
	-18	28.1	12.4	2.3	10.9	4.5	2.4
	-15	30.0	12.5	2.4	11.1	4.1	2.7
	-10	33.1	10.7	3.1	11.4	3.7	3.1
	-7	35.4	11.3	3.1	11.9	3.6	3.3
	2	38.4	11.1	3.5	11.8	2.7	4.3
	7	43.8	8.8	5.0	12.1	2.2	5.4
	10	47.1	9.0	5.2	12.4	2.1	5.9
	12	48.8	9.2	5.3	12.6	2.0	6.2
	15	49.3	9.1	5.4	12.6	2.0	6.4
20	50.2	8.9	5.6	12.7	1.9	6.7	
45	-20	24.9	12.9	1.9	10.6	5.3	2.0
	-18	26.9	12.9	2.1	10.8	5.3	2.0
	-15	29.0	13.1	2.2	11.1	5.0	2.2
	-10	32.4	12.5	2.6	11.7	4.5	2.6
	-7	34.7	12.3	2.8	12.0	4.2	2.8
	2	37.9	11.8	3.2	12.0	3.4	3.6
	7	41.9	10.2	4.1	12.2	2.9	4.3
	10	46.0	10.2	4.5	12.7	2.7	4.7
	12	47.4	10.2	4.7	13.0	2.6	5.0
	15	48.2	10.2	4.7	13.0	2.5	5.2
20	49.6	10.1	4.9	13.2	2.5	5.3	
50	-20	24.0	14.3	1.7	11.5	5.8	2.0
	-18	25.8	14.1	1.8	11.6	5.8	2.0
	-15	28.0	14.2	2.0	10.9	5.4	2.0
	-10	31.7	13.0	2.4	11.2	5.0	2.3
	-7	34.8	13.4	2.6	11.5	4.6	2.5
	2	37.3	12.9	2.9	11.7	3.7	3.1
	7	41.1	11.5	3.6	12.0	3.2	3.7
	10	45.1	11.1	4.1	12.3	3.0	4.1
	12	46.8	11.1	4.2	12.4	2.9	4.3
	15	47.4	11.0	4.3	12.5	2.8	4.4
20	49.0	11.0	4.5	12.6	2.8	4.5	
55	-20	23.2	15.3	1.5	11.1	6.6	1.7
	-18	24.7	15.3	1.6	11.2	6.6	1.7
	-15	27.0	15.3	1.8	11.5	6.2	1.9
	-10	30.9	13.5	2.3	11.6	5.4	2.2
	-7	33.9	14.2	2.4	11.8	5.1	2.3
	2	36.7	14.0	2.6	11.9	4.2	2.9
	7	40.2	12.7	3.2	12.0	3.6	3.3
	10	44.2	12.0	3.7	12.8	3.4	3.7
	12	46.1	11.9	3.9	12.8	3.3	3.9
	15	46.6	11.9	3.9	13.0	3.2	4.0
20	48.3	11.8	4.1	13.1	3.0	4.3	

$t_{VL}$  = heating flow temperature (°C)

$t_o$  = source temperature (°C)

$Q_h$  = heat output (kW), measured in accordance with standard EN 14511

P = power consumption for the overall unit (kW)

COP = Coefficient of Performance for the overall unit in accordance with standard EN 14511

Further performance data – heating  
see next page

**Observe daily power interruptions!**  
see “Engineering heat pumps general”

Performance data – heating

Belaria® pro (40)

Data according to EN 14511

$t_{VL}$ °C	$t_Q$ °C	Maximum output			Minimum output		
		$Q_h$ kW	P kW	COP	$Q_h$ kW	P kW	COP
60	-20	22.3	16.7	1.3	10.8	7.1	1.5
	-18	23.6	16.8	1.4	10.9	7.1	1.5
	-15	25.9	16.4	1.6	11.2	6.7	1.7
	-10	30.1	15.3	2.0	11.5	6.0	1.9
	-7	33.1	15.0	2.2	11.6	5.6	2.1
	2	36.1	15.0	2.4	11.3	4.8	2.3
	7	39.3	14.0	2.8	12.1	4.2	2.9
	10	43.3	12.8	3.4	12.4	3.8	3.2
	12	45.5	12.8	3.6	12.8	3.8	3.4
	15	45.8	12.8	3.6	12.8	3.7	3.5
70	20	47.5	12.5	3.8	12.9	3.5	3.7
	-20	-	-	-	-	-	-
	-18	-	-	-	-	-	-
	-15	-	-	-	-	-	-
	-10	25.2	15.4	1.6	10.9	7.1	1.5
	-7	28.8	15.3	1.9	10.9	6.5	1.7
	2	34.1	15.4	2.2	11.6	5.7	2.0
	7	39.2	15.6	2.5	12.1	5.2	2.3
	10	42.5	15.6	2.7	12.4	5.0	2.5
	12	44.8	15.6	2.9	12.8	4.9	2.6
15	45.4	15.6	2.9	12.4	4.7	2.7	
20	46.4	15.3	3.0	12.6	4.5	2.8	

$t_{VL}$  = heating flow temperature (°C)

$t_Q$  = source temperature (°C)

$Q_h$  = heat output (kW), measured in accordance with standard EN 14511

P = power consumption for the overall unit (kW)

COP = Coefficient of Performance for the overall unit in accordance with standard EN 14511

**Observe daily power interruptions!**  
see "Engineering heat pumps general"

**Performance data – heating**

Maximum heat output allowing for defrosting losses

**Belaria® pro (50)**

Data according to EN 14511

**Heat output –  $t_{VL}$  35 °C**

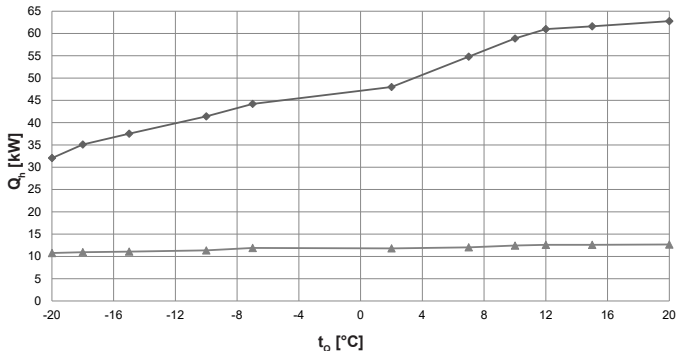

**Coefficient of performance –  $t_{VL}$  35 °C**

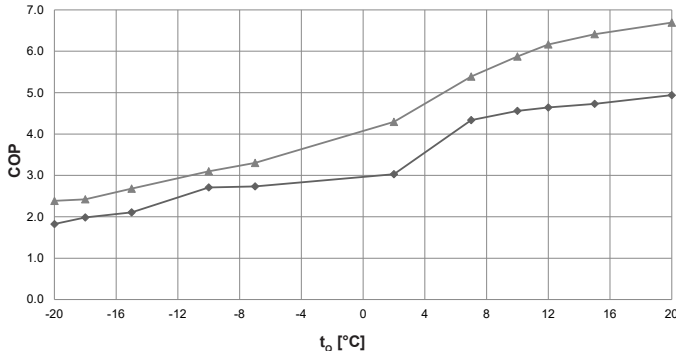

**Heat output –  $t_{VL}$  45 °C**

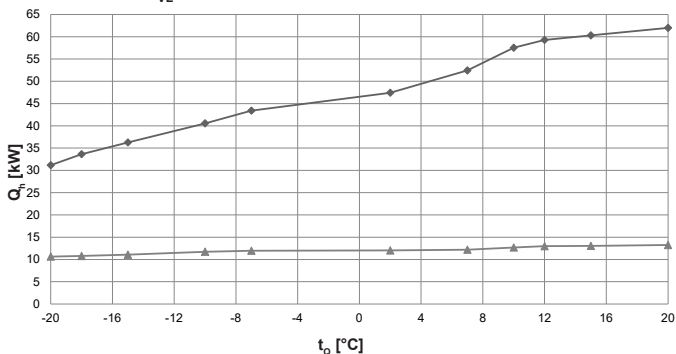

**Coefficient of performance –  $t_{VL}$  45 °C**

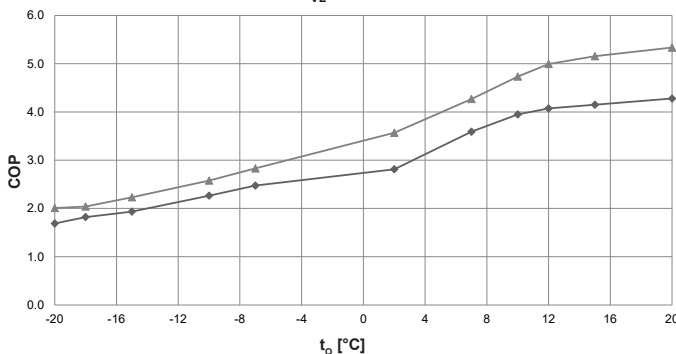

**Heat output –  $t_{VL}$  55 °C**

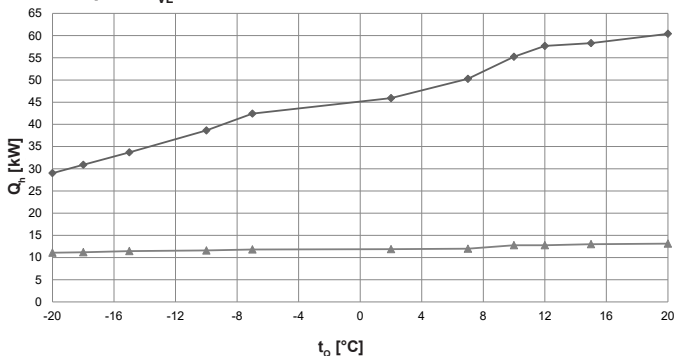

**Coefficient of performance –  $t_{VL}$  55 °C**

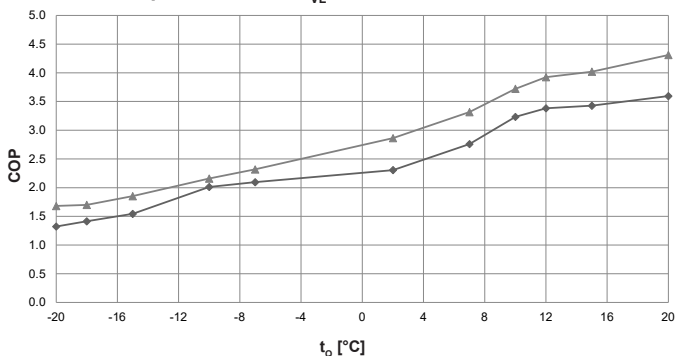

**Heat output –  $t_{VL}$  70 °C**

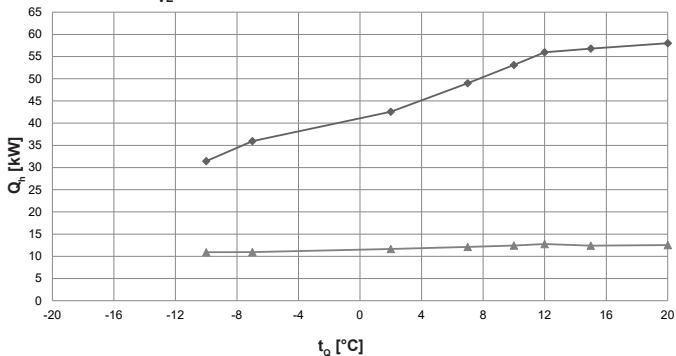

**Coefficient of performance –  $t_{VL}$  70 °C**

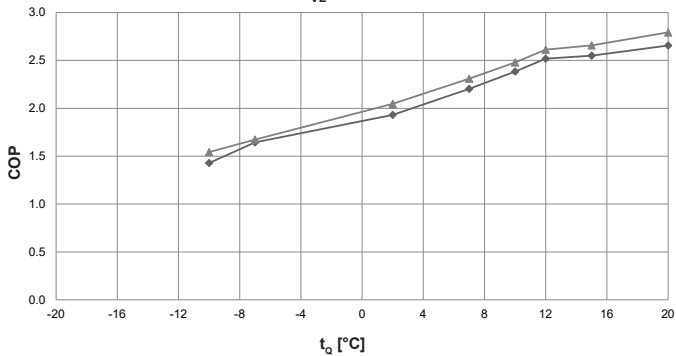

$t_{VL}$  = heating flow temperature (°C)

$t_q$  = source temperature (°C)

$Q_{h,Th}$  = heat output (kW), measured in accordance with standard EN 14511

COP = Coefficient of Performance for the overall unit in accordance with standard EN 14511

◆ Maximum output

▲ Minimum output

Performance data – heating

Belaria® pro (50)

Data according to EN 14511

t <sub>VL</sub> °C	t <sub>c</sub> °C	Maximum output			Minimum output		
		Q <sub>h</sub> kW	P kW	COP	Q <sub>h</sub> kW	P kW	COP
35	-20	32.1	17.6	1.8	10.8	4.5	2.4
	-18	35.1	17.7	2.0	10.9	4.5	2.4
	-15	37.5	17.8	2.1	11.1	4.1	2.7
	-10	41.4	15.3	2.7	11.4	3.7	3.1
	-7	44.2	16.2	2.7	11.9	3.6	3.3
	2	48.0	15.8	3.0	11.8	2.7	4.3
	7	54.8	12.6	4.3	12.1	2.2	5.4
	10	58.9	12.9	4.6	12.4	2.1	5.9
	12	61.0	13.1	4.6	12.6	2.0	6.2
	15	61.6	13.0	4.7	12.6	2.0	6.4
	20	62.8	12.7	4.9	12.7	1.9	6.7
45	-20	31.2	18.5	1.7	10.6	5.3	2.0
	-18	33.6	18.5	1.8	10.8	5.3	2.0
	-15	36.3	18.8	1.9	11.1	5.0	2.2
	-10	40.6	17.9	2.3	11.7	4.5	2.6
	-7	43.4	17.5	2.5	12.0	4.2	2.8
	2	47.4	16.9	2.8	12.0	3.4	3.6
	7	52.4	14.6	3.6	12.2	2.9	4.3
	10	57.5	14.6	3.9	12.7	2.7	4.7
	12	59.3	14.6	4.1	13.0	2.6	5.0
	15	60.3	14.5	4.1	13.0	2.5	5.2
	20	62.0	14.5	4.3	13.2	2.5	5.3
50	-20	30.0	20.5	1.5	11.5	5.8	2.0
	-18	32.3	20.2	1.6	11.6	5.8	2.0
	-15	35.0	20.3	1.7	10.9	5.4	2.0
	-10	39.6	18.6	2.1	11.2	5.0	2.3
	-7	43.4	19.1	2.3	11.5	4.6	2.5
	2	46.7	18.4	2.5	11.7	3.7	3.1
	7	51.3	16.4	3.1	12.0	3.2	3.7
	10	56.4	15.8	3.6	12.3	3.0	4.1
	12	58.5	15.8	3.7	12.4	2.9	4.3
	15	59.3	15.8	3.8	12.5	2.8	4.4
	20	61.2	15.6	3.9	12.6	2.8	4.5
55	-20	29.0	21.9	1.3	11.1	6.6	1.7
	-18	30.9	21.8	1.4	11.2	6.6	1.7
	-15	33.7	21.8	1.5	11.5	6.2	1.9
	-10	38.6	19.2	2.0	11.6	5.4	2.2
	-7	42.4	20.2	2.1	11.8	5.1	2.3
	2	45.9	19.9	2.3	11.9	4.2	2.9
	7	50.2	18.2	2.8	12.0	3.6	3.3
	10	55.2	17.1	3.2	12.8	3.4	3.7
	12	57.7	17.1	3.4	12.8	3.3	3.9
	15	58.3	17.0	3.4	13.0	3.2	4.0
	20	60.4	16.8	3.6	13.1	3.0	4.3

t<sub>VL</sub> = heating flow temperature (°C)

t<sub>c</sub> = source temperature (°C)

Q<sub>h</sub> = heat output (kW), measured in accordance with standard EN 14511

P = power consumption for the overall unit (kW)

COP = Coefficient of Performance for the overall unit in accordance with standard EN 14511

Further performance data – heating  
see next page

**Observe daily power interruptions!**  
see “Engineering heat pumps general”

Performance data – heating

Belaria® pro (50)

Data according to EN 14511

$t_{VL}$ °C	$t_G$ °C	Maximum output			Minimum output		
		$Q_h$ kW	P kW	COP	$Q_h$ kW	P kW	COP
60	-20	27.9	23.9	1.2	10.8	7.1	1.5
	-18	29.5	23.9	1.2	10.9	7.1	1.5
	-15	32.4	23.4	1.4	11.2	6.7	1.7
	-10	37.7	21.9	1.7	11.5	6.0	1.9
	-7	41.4	21.4	1.9	11.6	5.6	2.1
	2	45.2	21.5	2.1	11.3	4.8	2.3
	7	49.2	20.0	2.5	12.1	4.2	2.9
	10	54.1	18.4	2.9	12.4	3.8	3.2
	12	56.9	18.3	3.1	12.8	3.8	3.4
	15	57.3	18.2	3.1	12.8	3.7	3.5
70	20	59.4	17.9	3.3	12.9	3.5	3.7
	-20	-	-	-	-	-	-
	-18	-	-	-	-	-	-
	-15	-	-	-	-	-	-
	-10	31.4	22.0	1.4	10.9	7.1	1.5
	-7	35.9	21.9	1.6	10.9	6.5	1.7
	2	42.6	22.1	1.9	11.6	5.7	2.0
	7	49.0	22.2	2.2	12.1	5.2	2.3
	10	53.1	22.3	2.4	12.4	5.0	2.5
	12	56.0	22.2	2.5	12.8	4.9	2.6
15	56.8	22.3	2.5	12.4	4.7	2.7	
20	58.0	21.8	2.7	12.6	4.5	2.8	

$t_{VL}$  = heating flow temperature (°C)

$t_G$  = source temperature (°C)

$Q_h$  = heat output (kW), measured in accordance with standard EN 14511

P = power consumption for the overall unit (kW)

COP = Coefficient of Performance for the overall unit in accordance with standard EN 14511

**Observe daily power interruptions!**  
see “Engineering heat pumps general”

**Performance data – cooling**

Maximum cooling capacity

**Belaria® pro (40)**

Data according to EN 14511

**Cooling capacity –  $t_{VL} 18\text{ °C}$**

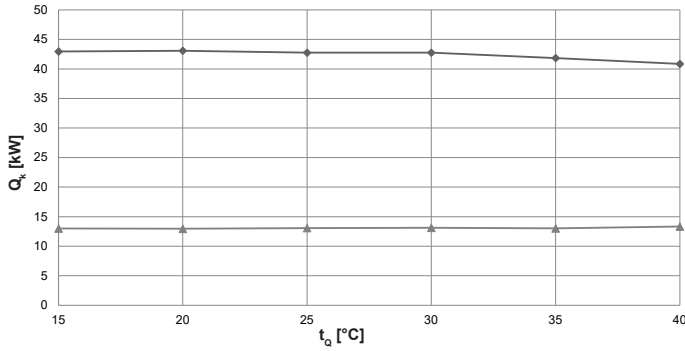

**Energy efficiency ratio –  $t_{VL} 18\text{ °C}$**

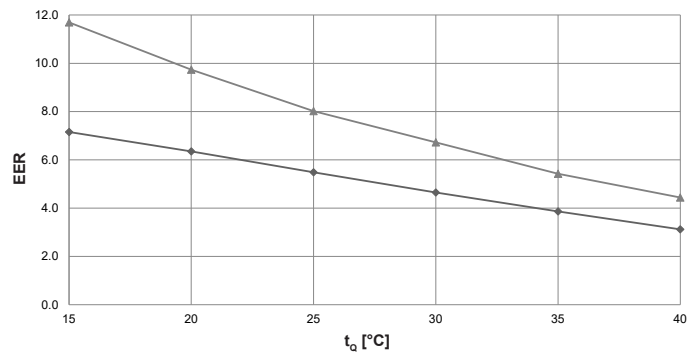

◆ Maximum output  
▲ Minimum output

**Belaria® pro (40)**

Data according to EN 14511

$t_{VL}$ °C	$t_o$ °C	Maximum output			Minimum output		
		$Q_k$ kW	P kW	EER	$Q_k$ kW	P kW	EER
7	15	42.4	10.0	4.2	13.1	1.8	7.3
	20	43.0	12.6	3.4	13.3	2.3	5.8
	25	41.4	13.9	3.0	13.1	2.7	4.8
	30	40.2	14.7	2.7	12.9	3.7	3.5
	35	38.2	16.0	2.4	12.3	4.3	2.8
	40	33.3	16.2	2.1	11.4	5.4	2.1
12	15	43.2	7.9	5.5	13.0	1.4	9.0
	20	42.8	8.9	4.8	13.1	1.7	7.5
	25	42.9	10.5	4.1	13.3	2.2	6.2
	30	43.1	12.9	3.3	13.4	2.7	5.1
	35	42.0	15.2	2.8	13.3	3.2	4.2
	40	38.6	17.0	2.3	12.4	3.6	3.4
18	15	43.0	6.0	7.2	13.0	1.1	11.7
	20	43.1	6.8	6.4	13.0	1.3	9.7
	25	42.8	7.8	5.5	13.1	1.6	8.0
	30	42.8	9.2	4.6	13.1	2.0	6.7
	35	41.8	10.8	3.9	13.0	2.4	5.4
	40	40.9	13.1	3.1	13.3	3.0	4.4

$t_{VL}$  = cooling water flow temperature (°C)

$t_o$  = source temperature (°C)

$Q_k$  = cooling capacity (kW), measured in accordance with standard EN 14511

P = power consumption for the overall unit (kW)

EER = Energy Efficiency Ratio for the overall unit in accordance with standard EN 14511

**Observe daily power interruptions!**  
see "Engineering heat pumps general"

**Performance data – cooling**

Maximum cooling capacity

**Belaria® pro (50)**

Data according to EN 14511

**Cooling capacity –  $t_{VL} 18\text{ °C}$**

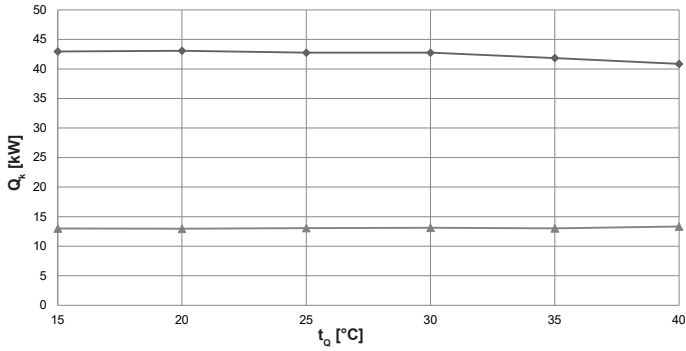

**Energy efficiency ratio –  $t_{VL} 18\text{ °C}$**

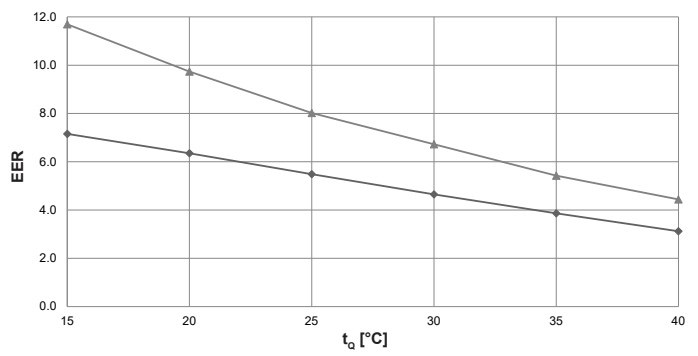

◆ Maximum output  
▲ Minimum output

**Belaria® pro (50)**

Data according to EN 14511

$t_{VL}$ °C	$t_Q$ °C	Maximum output			Minimum output		
		$Q_k$ kW	P kW	EER	$Q_k$ kW	P kW	EER
7	15	42.4	10.0	4.2	13.1	1.8	7.3
	20	43.0	12.6	3.4	13.3	2.3	5.8
	25	41.4	13.9	3.0	13.1	2.7	4.8
	30	40.2	14.7	2.7	12.9	3.7	3.5
	35	38.2	16.0	2.4	12.3	4.3	2.8
	40	33.3	16.2	2.1	11.4	5.4	2.1
12	15	43.2	7.9	5.5	13.0	1.4	9.0
	20	42.8	8.9	4.8	13.1	1.7	7.5
	25	42.9	10.5	4.1	13.3	2.2	6.2
	30	43.1	12.9	3.3	13.4	2.7	5.1
	35	42.0	15.2	2.8	13.3	3.2	4.2
	40	38.6	17.0	2.3	12.4	3.6	3.4
18	15	43.0	6.0	7.2	13.0	1.1	11.7
	20	43.1	6.8	6.4	13.0	1.3	9.7
	25	42.8	7.8	5.5	13.1	1.6	8.0
	30	42.8	9.2	4.6	13.1	2.0	6.7
	35	41.8	10.8	3.9	13.0	2.4	5.4
	40	40.9	13.1	3.1	13.3	3.0	4.4

$t_{VL}$  = cooling water flow temperature (°C)  
 $t_Q$  = source temperature (°C)  
 $Q_k$  = cooling capacity (kW), measured in accordance with standard EN 14511  
 P = power consumption for the overall unit (kW)  
 EER = Energy Efficiency Ratio for the overall unit in accordance with standard EN 14511

**Observe daily power interruptions!**  
 see “Engineering heat pumps general”

**Belaria® pro**  
**Outdoor unit**  
 (Dimensions in mm)

Front view

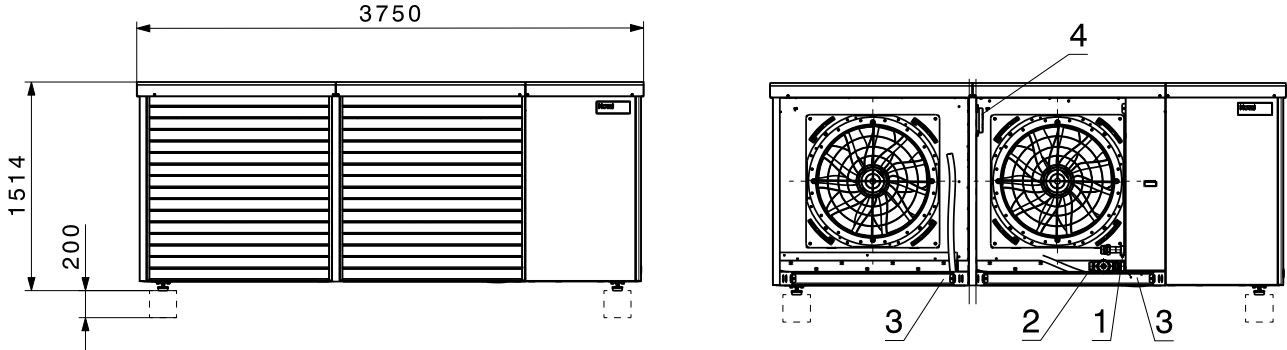

View from the left

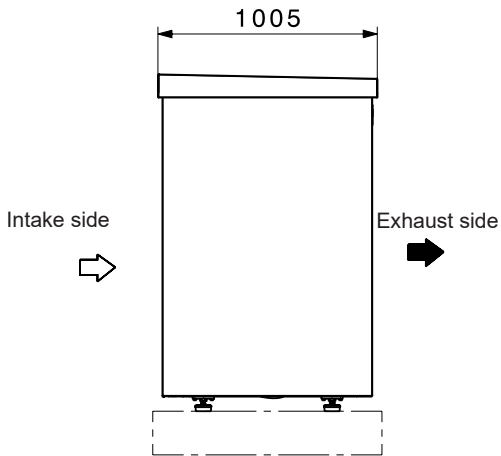

View from top

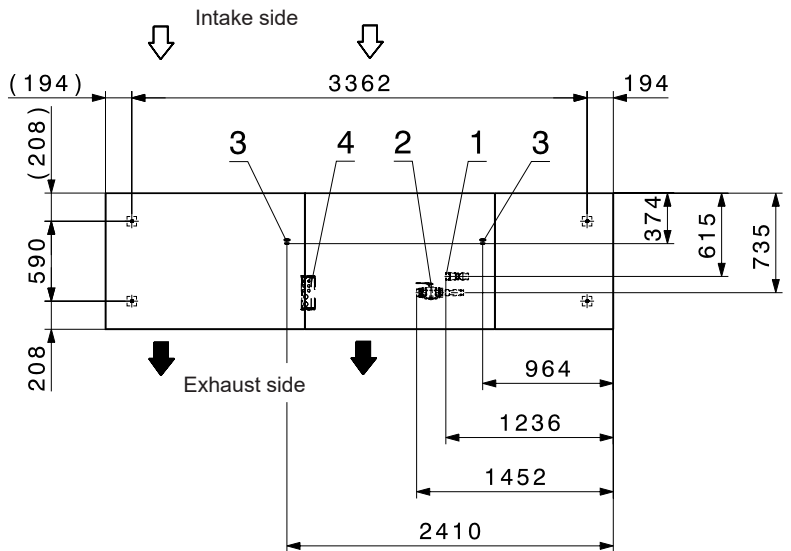

- 1 Connection hydraulic connection line flow 2" ET
- 2 Connection hydraulic connection line return 2" ET
- 3 Condensate drain 1 + 2 1"
- 4 Electrical connection

Centre of gravity

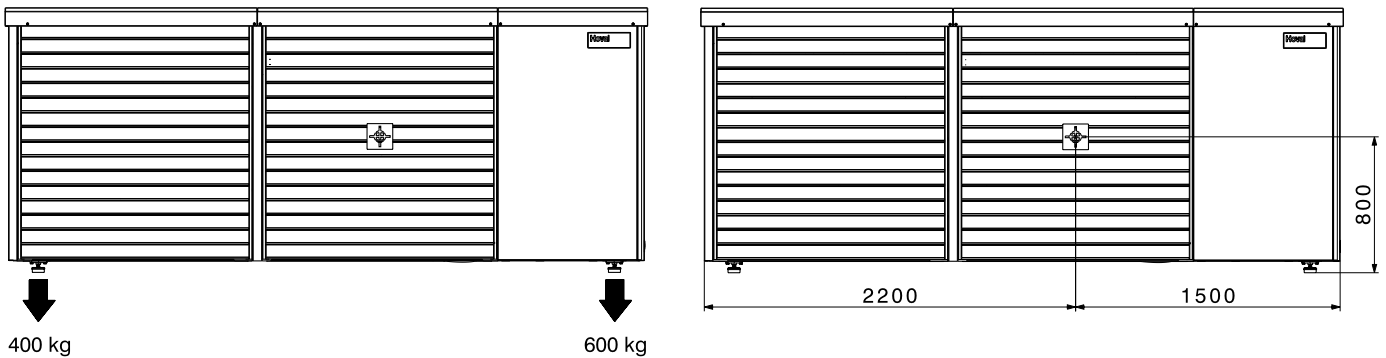

**Belaria® pro (40,50)**  
**Electrical box**  
 (Dimensions in mm)

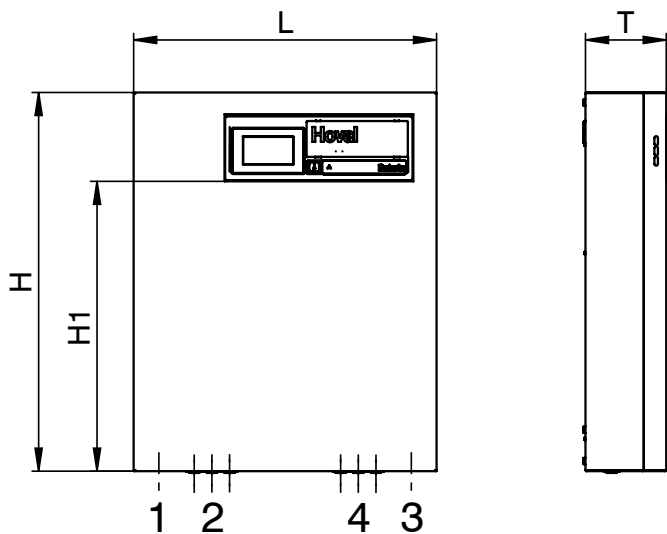

Type	L	H	H1	T
Belaria® pro (40,50)	600	750	574	160

- 1 Cable feed-in control current, main current
- 2 Optional: Cable feed-in control current, main current
- 3 Cable feed-in sensors, RS485
- 4 Optional: Cable feed-in sensors, RS485

**Belaria® pro (40,50)**  
**Electrical box**

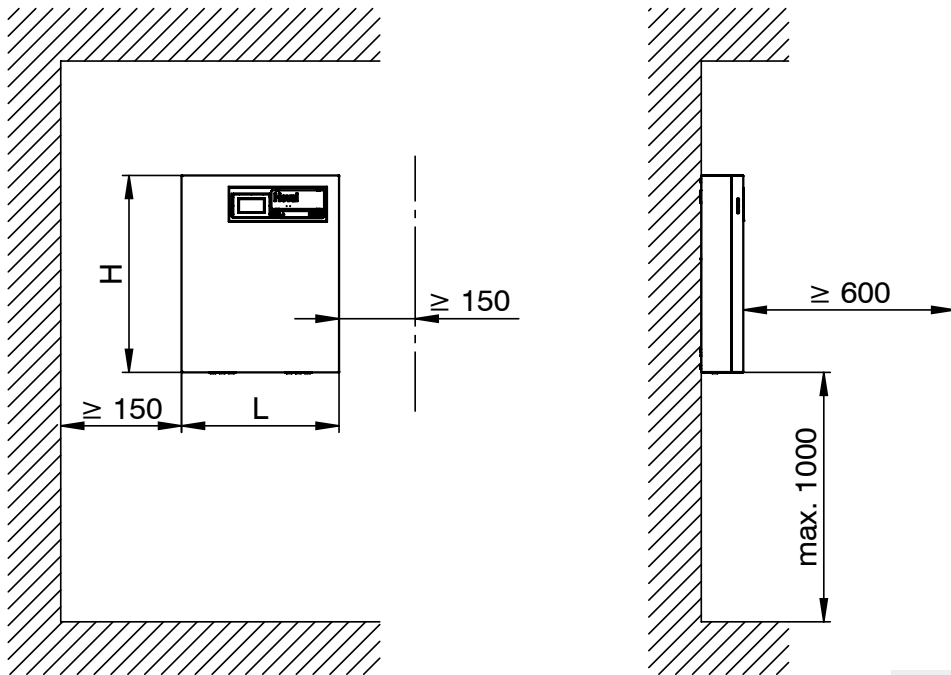

To ensure good operability and accessibility to the electrical connections, a clearance of max. 1000 mm must be provided from the ground to the lower edge of the electrical box.

**Space requirement**  
(Dimensions in mm)

**Belaria® pro**  
**Outdoor unit**

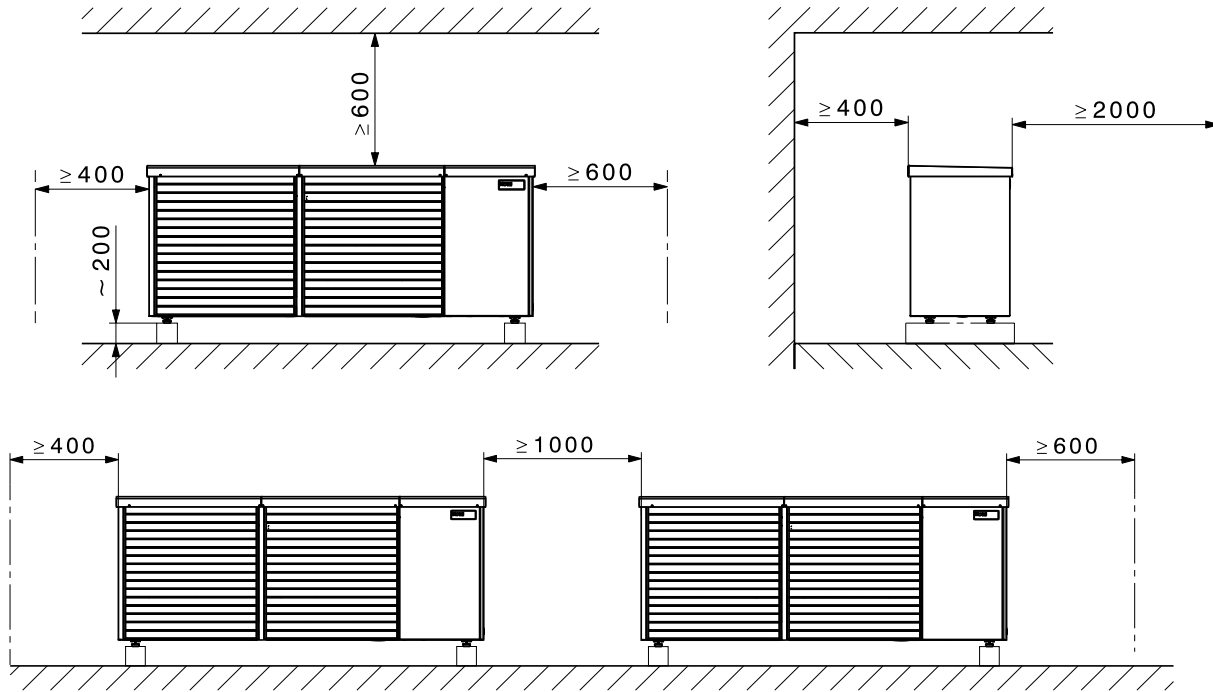

Any possible openings/recesses and ignition sources must be avoided within a radius of one meter around the outdoor unit.

In order to ensure accessibility during maintenance, a clearance of at least 600 mm upwards must be maintained. For any service work, the minimum clearances at the rear and sides of the heat pump must be observed.

**Belaria® pro**  
**Outdoor unit**

**View from above**

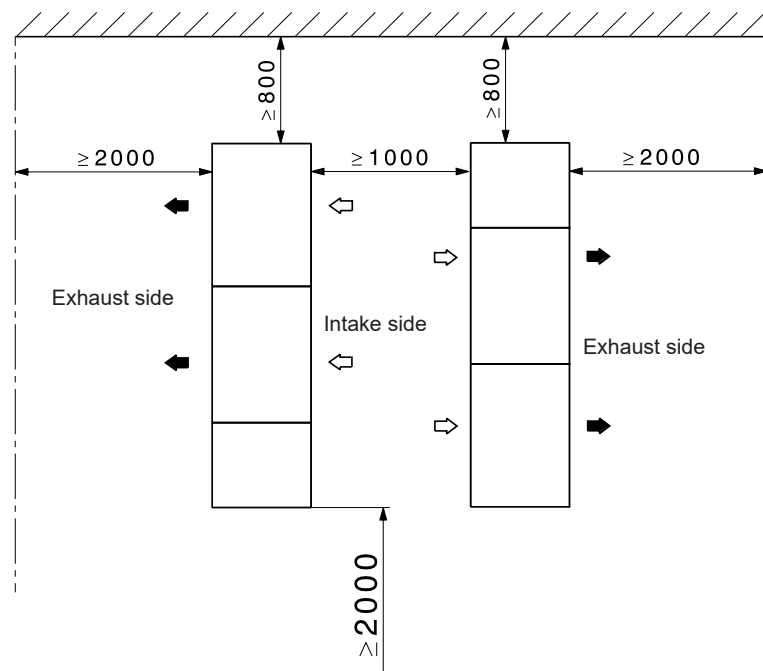

**Presentation of protection areas**

Belaria® pro (40,50) with refrigerant R290  
(Dimensions in mm)

**Floor plan – protection area when installed in front of a wall**

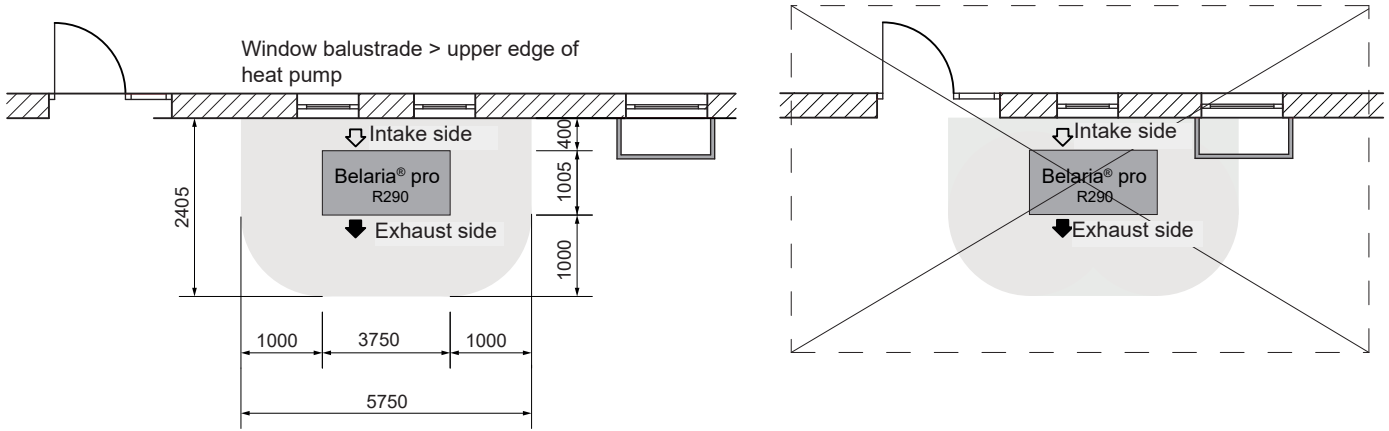

**View – protection area when installed in front of a wall**

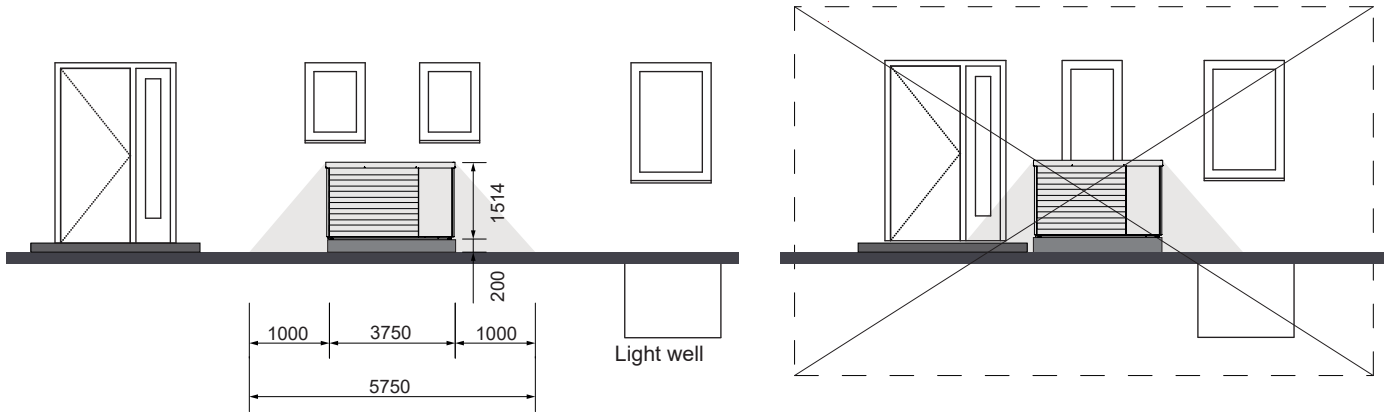

- The heat pump (outdoor unit) is only allowed to be placed outdoors and under no circumstances indoors.
- The outdoor unit is filled with the non-toxic, odourless and colourless but flammable refrigerant R290 (propane), which is heavier than air. If this escapes, there is a danger of fire/explosion. Therefore, all potential sources of ignition must be kept at least 1 m away in all directions. Smoking and the use of naked flames is prohibited in this area.
- Window balustrades must be higher than the upper edge of the outdoor unit in the protection area!
- The heat pump must be at least 1 m from the property boundary; observe building regulations!
- At the entrances to properties, it must be ensured that no vehicle can enter the protection area.
- To prevent the heat pump from being touched by vehicles, a collision guard must be installed if necessary. This must be located outside the protected area.

**Floor plan – protection area when installed outdoors**

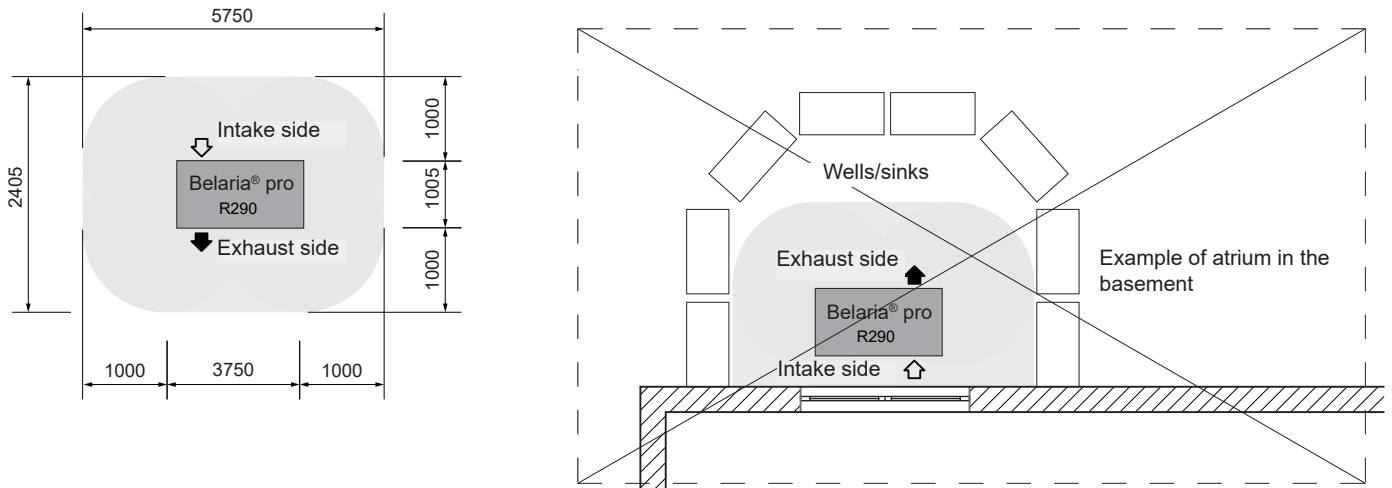

Floor plan flat roof – protection area

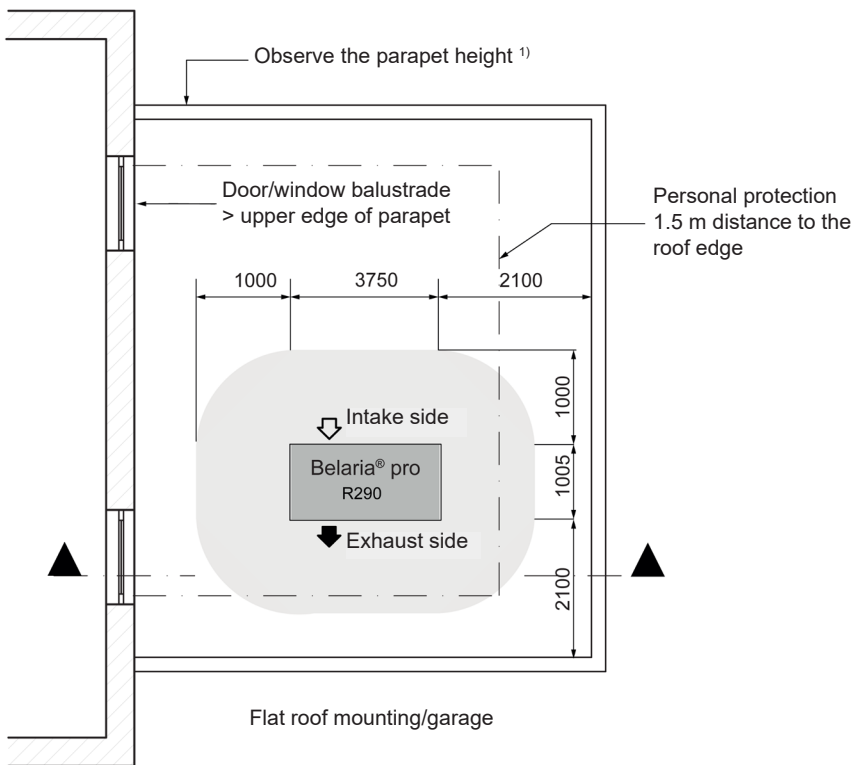

<sup>1)</sup> In case of flat roof installation, the parapet must not represent a potential sink in which refrigerant could accumulate.

Section flat roof – protection area

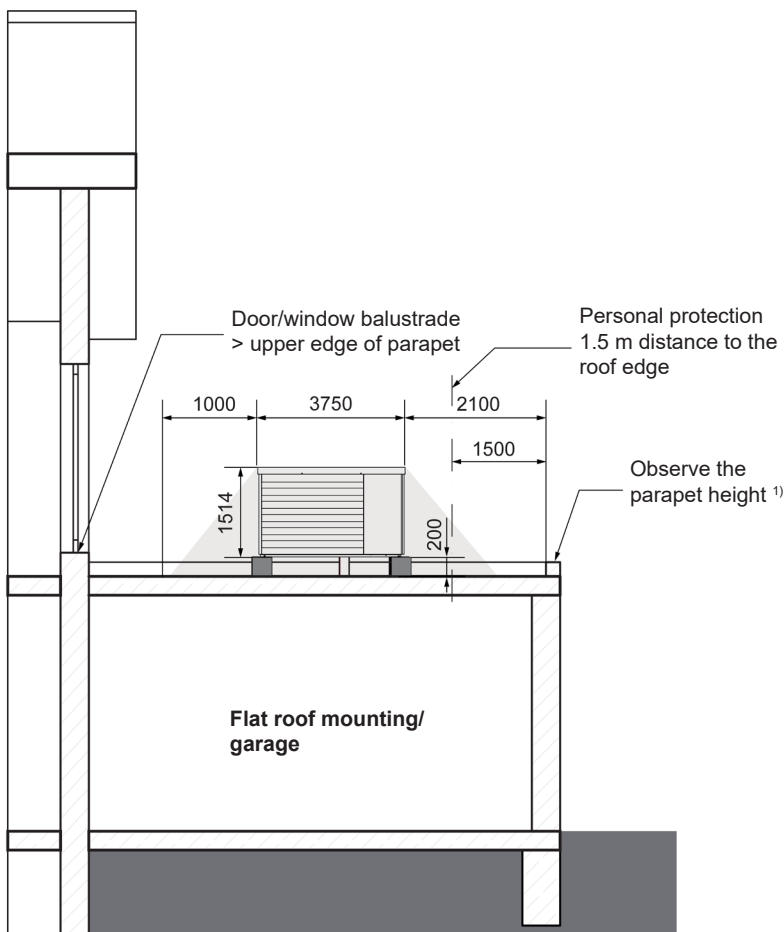

- Strict compliance with safety measures regarding combustible refrigerants.
- All standards concerning statics, wind load and access to roofs must be complied with. The outdoor unit must be firmly bolted onto the substructure (e.g. strip foundation). The heat pump must be prevented from tilting.
- Minimum distance of the heat pump to the roof edge: 1.5 m (personal protection) + 0.6 m (working area refrigeration circuit).
- Accessibility for maintenance and repair work must be ensured. For work on the heat pump, a measuring case and test equipment, refrigerant bottle, etc. must be transported to the site, amongst other things. In addition to the safety equipment (fall protection devices, anchoring devices, etc.), this must also be taken into account for skylights, stairs, railings, etc.
- There must be no floor-to-ceiling doors/windows to the flat roof, or balustrade must be higher than the parapet.
- Protection areas around windows must be complied with.
- There must not be any pipe vents, skylights or the like on the flat roof within a radius of 1 m from the heat pump.
- If there is a risk of frost, a siphon must be installed in the shaft immediately before the condensate drain is introduced into the downpipe.
- Condensate drain into the sewage system via a frost-proof siphon or allow it to seep away freely.

**Installation variants for Belaria® pro outdoor unit**  
(Dimensions in mm)

**Firm strip foundation or floor plate (1) on site**

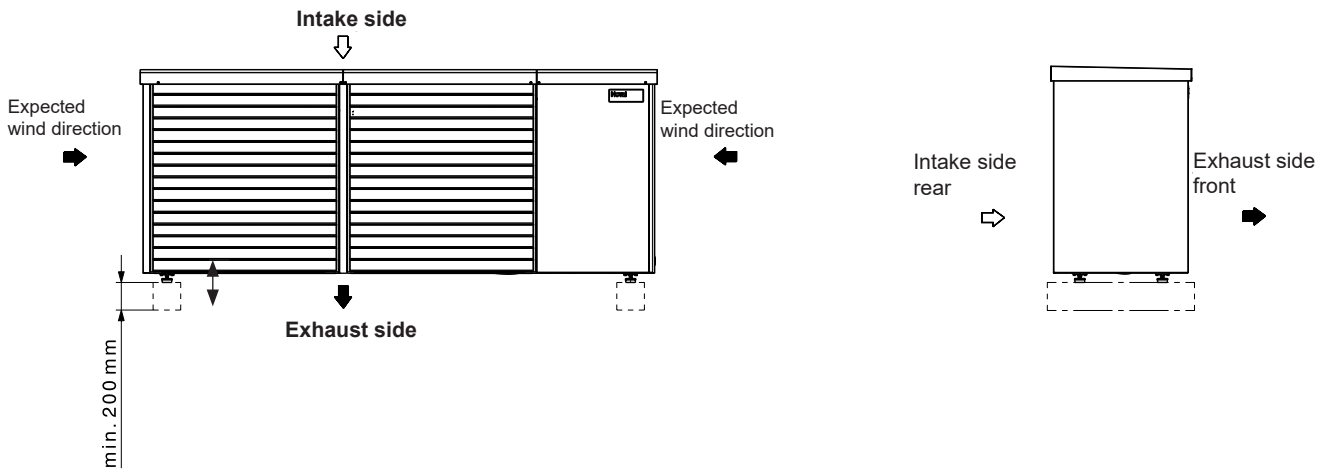

The base must not form a sink. A circumferential base is therefore not permitted.

**Installation variants for Belaria® pro outdoor unit**  
(Dimensions in mm)

**Strip foundation**

Plan  
(view from above)

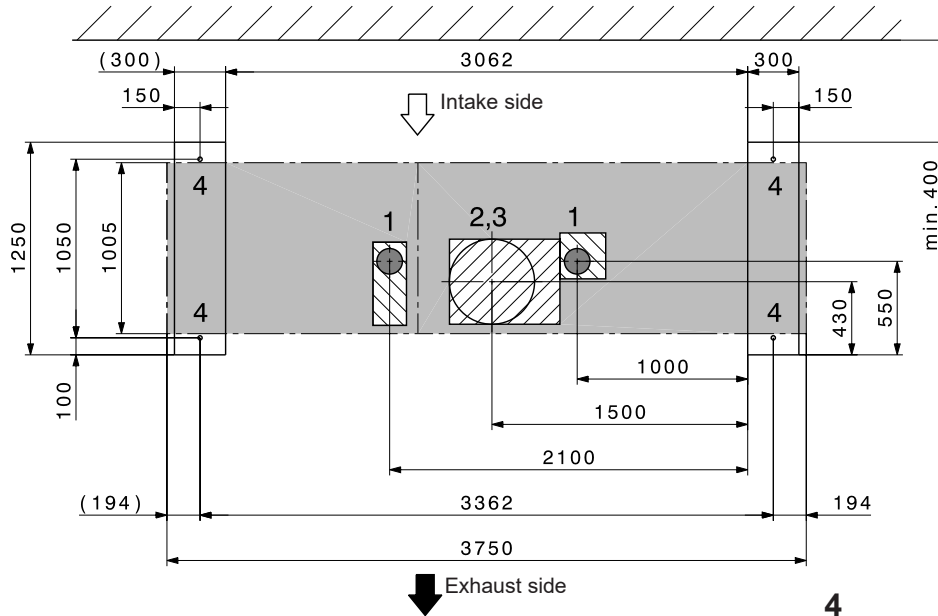

- 1 Condensate drain area
- 2 Area Flow hydraulics  
Return hydraulics
- 3 Electrics area
- 4 Attachment points on the strip foundation  
(dowels included in scope of delivery)

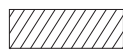
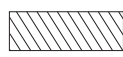
-  Possible area for empty tubes in the strip foundation
-  Possible area for condensate drain in the strip foundation

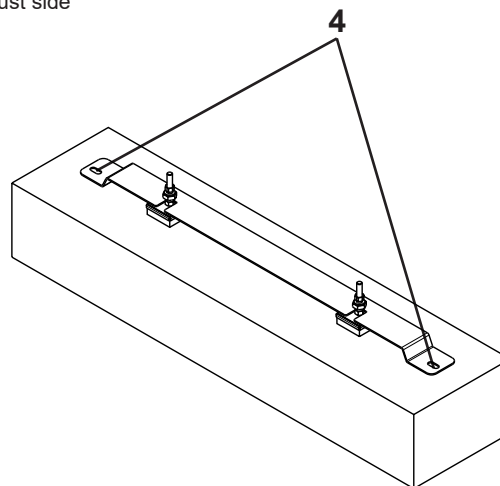

Configuration and connection diagram Belaria® pro (40,50)

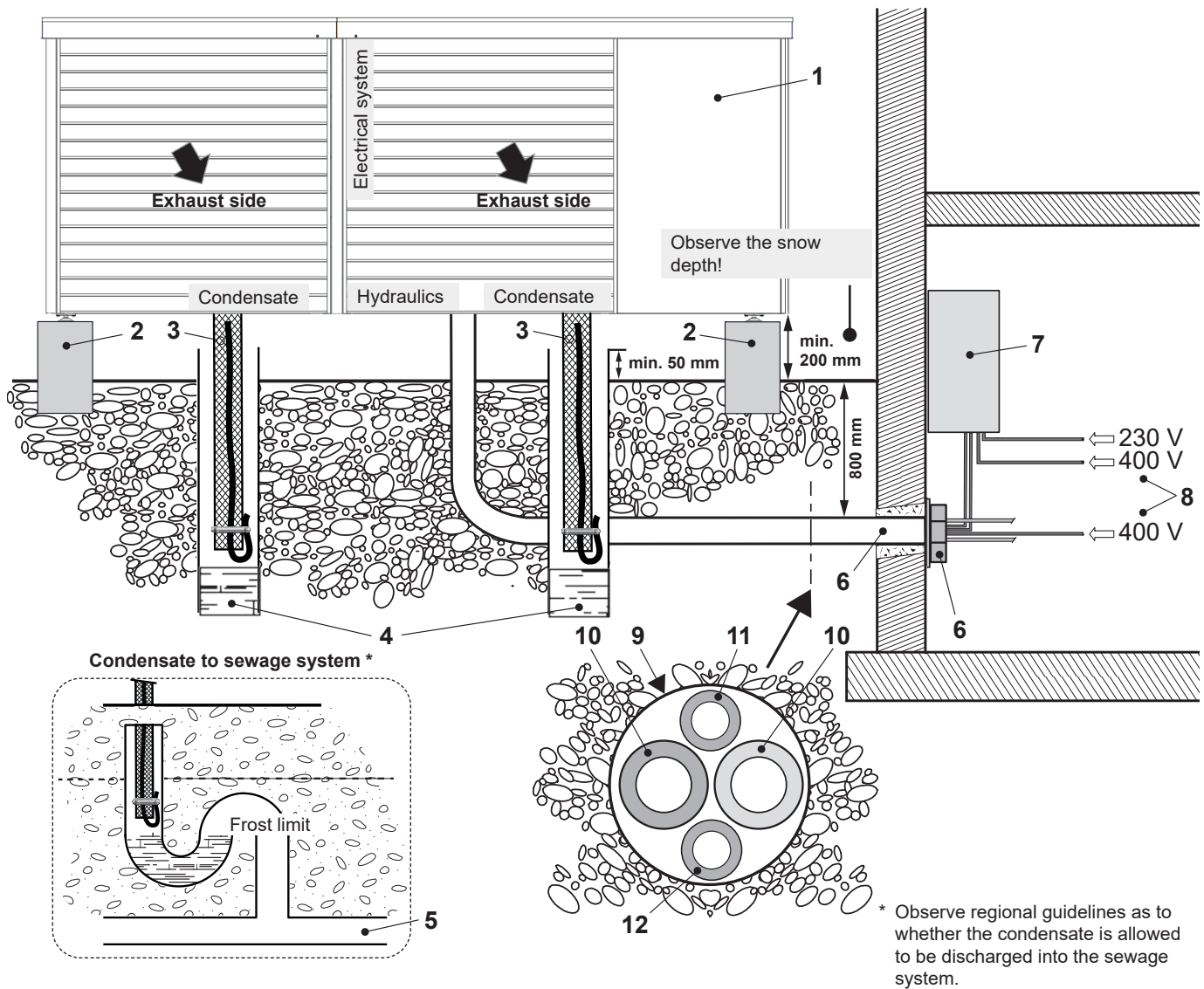

- 1 Outdoor unit
- 2 Stip foundation
- 3 Condensate drain heat pump Ø 28 mm, drain pipe DN 100
- 4 Variant 1: Seepage (duct/gravel layer)
- 5 Variant 2: Discharging into the sewage system (penetration into the soil must be made leak-tight)
- 6 Wall lead-through (hydraulic and electrical connections)
- 7 Electrical box

- 8 Main current: 3 x 400 V/50 Hz  
Control current: 1 x 230 V/50 Hz  
Data bus RS485
- 9 Empty tube for hydraulics and electrics
- 10 Connection line flow and return
- 11 Empty tube for electrical connections for outdoor unit  
Main current outdoor unit: 3 x 400 V/50 Hz  
Control current outdoor unit: 1 x 230 V/50 Hz
- 12 Empty tube for data bus RS485

### Requirements and directives

The general requirements and directives listed in the chapter Engineering apply.

### Set-up

- The distance between the outdoor unit and the buffer storage tank must be as short as possible. Only short and simple routing of lines guarantees cost effectiveness and low heat losses.
- The maximum permitted single cable length is 30 m between the outdoor unit and the buffer storage tank. This must not be exceeded.  
In general, the customer must assess whether the next larger pipe dimension is more suitable due to the pressure drop.
- There must be no building openings (windows, doors, shafts, ventilation openings, etc.) within a radius of 1 m from the outdoor unit and no potential ignition sources must be present.
- Wall ducts into the building must be airtight.
- The outdoor unit must not be placed in or near floor recesses.
- The outdoor unit must not be placed closer than 1 m to the boundary of the property. Country-specific regulations must be observed.
- The air intake and air exhaust sides must not be narrowed or blocked. The air exhaust side must be unobstructed (> 2 m).
- When using glycol (antifreeze) – primary and/or secondary – a separating system must be used.
- Filling the entire system with glycol or a frost protection agent/water mixture is considered improper use and is not permitted. If this is nevertheless desired for frost protection reasons, the system must be designed with a system separation. Only environmental compatible frost protection agent is allowed to be used.

### Outdoor unit

#### Important safety instruction

The heat pump (outdoor unit) is only allowed to be placed outdoors and under no circumstances indoors.

The outdoor unit is filled with the non-toxic, odourless and colourless but flammable refrigerant R290 (propane), which is heavier than air. If this occurs, there is a danger of fire/explosion. Therefore, all potential sources of ignition must be kept at least 1 m away in all directions. Smoking and the use of naked flames is prohibited in this area.

The outdoor unit is installed outdoors. The installation location must be selected carefully. It is essential that the following ancillary conditions are met:

- The maximum line length must not be exceeded.
- The connection lines must be laid insulated and frost-proof.
- The installation location must be chosen in such a way that no noise pollution can occur (do not install near bedrooms, keep a distance from neighbours), hedges and bushes can have a sound-absorbing effect.

- Unobstructed air inflow and outflow must be possible.
- It is imperative that the minimum distances are observed (see Dimensions/Space requirement).
- The intake air must be free of impurities such as sand and aggressive substances such as ammonia, sulphur, chlorine etc.
- The outdoor unit must be installed on a load-bearing fixed structure.
- If the unit is installed at wind-prone locations, the alignment of the heat pump must be selected in such a way that the expected wind direction is crossways to the intake direction of the outdoor unit.
- If an alternative installation in areas subject to strong winds cannot be avoided, an additional wind shield in the form of a hedge, for example, should be installed, or additional fastening should be provided for the outdoor unit.
- At exposed installation locations prone to wind load, e.g. on building roofs, the surface load on the upper horizontal cover surface of the heat pump caused by wind suction must not exceed a value of 2000 N/m<sup>2</sup>. The heat pump casing might be damaged if this value is not complied with.
- The permitted surface load must be determined in accordance with the specifications of standard EN 1991-1-1. Compliance must be checked by a qualified specialist. A professional inspection of the actual conditions on site is mandatory and must be carried out by a qualified specialist.
- When planning and installing the heat pump in locations exposed to wind load, please contact your sales consultant in good time.
- Notice on installing the cover: If the cover of the heat pump has been removed, it must be properly reinstalled after the work has been completed. Make sure that the cover is fully connected to the heat pump using all the screw holes provided, to ensure stability and tightness.
- If the installation location is not protected against snowfall, it must be chosen in such a way that the evaporator remains free of snow.
- The outdoor unit must always be installed on a solid surface in a horizontal position. This can be achieved by means of a strip foundation.
- The load-bearing capability must be adequate. The unit must be fixed with 4 M12 screws.
- Air heat pumps generate condensate during operation. This can amount to 15 litres per evaporator unit per defrost cycle within 2 minutes for the outdoor unit of the Belaria® pro.
- The condensate drain must be frost-proof so that the condensate can flow away without problems even at outdoor temperatures below 0 °C.
- If the discharge is into the sewage system, a siphon must be provided and the duct lead-through into the ground must be sealed so that no refrigerant can enter the sewage system uncontrolled.
- If there is a risk of frost, a siphon must be installed in the shaft immediately before the condensate drain is introduced into the downpipe.
- The condensate drip trays integrated in the outdoor unit are already equipped with tray heating at the factory that thus prevents freezing.
- The condensate drain lines are also secured with the pre-installed heating tapes.
- The air exhaust has increased susceptibility to frost. Gutters, water pipes and water containers must not be situated right next to the exhaust.
- If installed near the coast, the location must be at least 5 km from the coastline. If this safe distance is not complied with, increased corrosion can be expected. These cases are excluded from the warranty.
- To prevent damage caused by animals such as rodents or insects, all cable ducts must be properly sealed.
- The hydraulic lines from the heat pump can transmit structure-borne noise. Therefore, structure-borne noise decoupling should be provided, e.g. with sound-insulating hoses.

A strainer is located in the outdoor unit. At least one sludge and magnetite separator must be installed in the heating return.

### Flat roof installation

Flat roof installation of the Belaria® pro is possible under the following conditions:

- Strict compliance with safety measures regarding flammable refrigerants (see below).
- All standards concerning statics, wind load and access to roofs must be complied with. The outdoor unit must be firmly bolted onto the substructure (e.g. strip foundation). The heat pump must be prevented from tilting.
- Minimum distance of the heat pump to the roof edge: 1.5 m (personal protection) + 0.6 m (working area refrigeration circuit).
- Accessibility for maintenance and repair work must be ensured. For work on the heat pump, a measuring case and test equipment, refrigerant bottle, etc. must be transported to the site, amongst other things. In addition to the safety equipment (fall protection devices, anchoring devices, etc.), this must also be taken into account for skylights, stairs, railings, etc.
- At exposed installation locations prone to wind load, e.g. on building roofs, the surface load on the upper horizontal cover surface of the heat pump caused by wind suction must not exceed a value of 2000 N/m<sup>2</sup>. The heat pump casing might be damaged if this value is not complied with.
- The permitted surface load must be determined in accordance with the specifications of standard EN 1991-1-1. Compliance must be checked by a qualified specialist. A professional inspection of the actual conditions on site is mandatory and must be carried out by a qualified specialist.
- When planning and installing the heat pump in locations exposed to wind load, please contact your sales consultant in good time.

- Notice on installing the cover: If the cover of the heat pump has been removed, it must be properly reinstalled after the work has been completed. Make sure that the cover is fully connected to the heat pump using all the screw holes provided, to ensure stability and tightness.
- The heat pump contains electrically operated components and must be integrated in the structural lightning and surge protection for roof structures.

#### Safety measures to be complied with

- There must be no building openings (windows, doors, shafts, ventilation openings, etc.) within a radius of 1 m from the outdoor unit and no potential ignition sources must be present.
- Wall ducts into the building must be airtight.
- The outdoor unit must not be placed in or near floor recesses.
- The outdoor unit must not be placed closer than 1 m to the boundary of the property. Country-specific regulations must be observed.
- The air intake and air exhaust sides must not be narrowed or blocked. The air exhaust side must be unobstructed (> 2 m).
- The condensate is allowed to be directed into a shaft. A siphon must be installed upstream of the connection to the down-pipe. The siphon must be located inside the building.

#### Electrical box

- The installation location must be selected in accordance with the valid requirements and directives.
- The electrical box must be installed in a room protected against frost, by an approved specialist company. Room temperature must be between 5 °C and 25 °C.
- Installation in wet rooms, dusty rooms or rooms with a potentially explosive atmosphere is not permitted.
- The electrical connections can be introduced from the bottom with the electrical box of the Belaria® pro.
- To ensure accessibility to the electrical box, the distances must be maintained on all sides (see Dimensions/Space requirement).

#### Electrical connections

- The electrical connection must be carried out by a qualified technician and registered with the responsible energy supply company. The relevant electrical installation company is responsible for ensuring that electrical connection is carried out in accordance with standards and that safeguard measures are put in place.
- The mains voltage at the connection terminals of the heat pump must be 400 V or 230 V ± 10 %. The connection lines specified in the technical data must be checked by the electrical company carrying out the work depending on the line length, the routing type and the type of line.

- A fault-current circuit breaker is recommended. Country-specific requirements must be complied with. If the “fault-current circuit breaker” safeguard measure is implemented by the electrical company, a separate fault-current circuit breaker is recommended for the heat pump.
- This fault-current circuit breaker must be of the all-current-sensitive type B ( $I_{\Delta N} \geq 300$  mA). The specified RCCB types apply to the heat pump regardless of externally connected components (refer to assembly instructions, data sheets).
- Owing to the starting currents that occur, circuit breakers with a type “C” or “K” tripping characteristic are to be used for the main circuit.
- For the control circuit and additional electric heating (if present), circuit breakers with a type “B” or “Z” tripping characteristic are sufficient.
- The electrical connection and feeder lines must be copper cables.
- Please refer to the circuit diagrams for electrical details.
- The wall feedthrough should slope down from the inside to the outside.
- To avoid damage, the opening should be padded on the inside or, for example, lined with a PVC pipe.
- After installation, the wall opening must be sealed with a suitable sealing compound on site, observing the fire protection regulations.

#### Routing of the hydraulic connection lines

- If the hydraulic connection lines are laid in the ground, this must be done in a protective tube. For example, this can be a PVC pipe with a diameter of 350 mm.
- Wall ducts must be sealed to the outside on site.
- After the hydraulic connection lines have been laid, they must be checked for damage and reinsulated. In case of cooling, condensate can form on the pipes.
- The hydraulic connection lines must be laid decoupled from the building and must never be laid flush-mounted.
- Care must be taken to ensure that water pipes do not pass through the sleeping or living areas.
- Shut-off valves must be installed on site in accordance with the corresponding hydraulic diagram. The shut-off valves are not allowed to be opened until immediately before commissioning.
- The danger of frost damage must be taken into account if there are prolonged power outages.
- False flow rates as a result of incorrect dimensions of the pipework, incorrect fittings or improper pump operation can cause damage to the heat pump.

#### Room cooling

- Room cooling can be provided by fan convectors and is recommended. The connection lines for the fan convectors must have condensation-proof insulation. In addition, the condensate from the fan convectors must be drained off.
- If panel heating is used for room cooling, various criteria such as temperatures below the dewpoint or the temperature profiles must be allowed for, and can lead to costly consequential damage in the case of inadequate planning or incorrect use. We recommend that you consult Hoval.

#### Further guidelines see “Engineering”

#### Connection on drinking water side

- The hydraulic connection is made according to the information in the corresponding diagrams from Hoval.
- According to the Drinking Water Regulation and DIN 50930-6, the domestic hot water storage tank is suitable for normal drinking water (pH value > 7.3).
- The connection piping can be made using galvanised pipes, stainless steel pipes, copper pipes or plastic pipes.
- The connections must be made pressure-tight.
- The safety devices tested for the components in accordance with DIN 1988 and DIN 4753 must be installed in the cold water pipe.
- The 10 bar operating pressure stated on the data plate is not allowed to be exceeded. Install a pressure reducing valve if necessary.
- A suitable water filter must be installed in the cold water pipe.
- A water softener must be installed if the water is hard.

#### Installation on heating side

- All pertinent laws, regulations and standards for heating house pipework and for heat pump systems must be complied with.
- A strainer is located in the outdoor unit. At least one sludge and magnetite separator must be installed in the heating return.
- The safety and expansion devices for closed heating systems must be provided in accordance with EN 12828.
- Dimensioning of the pipework must be done according to the required flow rates and given pressure drops.
- Ventilation possibilities must be provided at the highest points and drainage possibilities at the lowest points of the connection lines.
- To prevent energy losses, the connection lines must be insulated with suitable material in accordance with local regulations.

**Transport and storage**

- When removing the packaging, check the outdoor unit for damage. If the outdoor unit was damaged during transport or storage, contact Hoval customer service, a service partner or a licensed specialist immediately. They must carry out a leak test with a suitable leak detector. In the event of a leak, the outdoor unit must be repaired.
- Store the outdoor unit in a cool place without fire hazard and without direct exposure to heat sources. The ambient temperature must not exceed 43 °C.
- The same regulations apply for storage as for installation (no recesses, ventilation pipes, ignition sources in the storage area).
- The outdoor unit must not be stored in closed rooms, cellars or garages.
- The outdoor unit is only allowed to be stored outdoors.
- During transport, ensure sufficient ventilation in the closed vehicle, also when parking and stopping.
- Storage in passageways, escape routes or in front of entrances or exits is not permitted.
- Ignition sources such as naked flames, switched-on gas appliances, electric heaters, etc. must be kept away from the unit.
- Transport and storage only in upright position. Protect from mechanical damage and from falling over or falling down (make sure the load is secure).
- To prevent damage during transport, the outdoor unit should be moved to its final installation location as far as possible in packed state on the wooden pallet with a forklift or lift truck.
- Transport by crane: The outdoor unit can be lifted by a crane and transported to the installation site. For this purpose, there are three crane hooks below the cover with openings for the passage of the transport straps.

**Prerequisites for commissioning**

- Commissioning at cold outdoor temperatures is only possible if the system is pre-heated on site (e.g. with an electric bake-out device). During commissioning, the room temperature of the heated rooms must be at least 15 °C (compressor operation is not possible below this temperature, as there would be too little energy for defrosting). If a buffer storage tank is provided, its heating water temperature is not allowed to be less than 20 °C during commissioning.
- A heat pump should not be used for drying out of the building (screed heating), as this can significantly reduce the service life of the device. Alternatively, heating via a mobile heating station or E-set is a sensible option. This is particularly true for air/water heat pumps, since the heating output here is strongly dependent on the outdoor temperature and drying out of the building is not possible at temperatures below the frost line in the building carcass.

**Hoval quality.**  
You can count on us.

Hoval is one of the leading international companies for heating and indoor climate solutions. Drawing on more than 80 years of experience and benefiting from a close-knit team culture, the Hoval Group delivers exciting solutions and develops technically superior products. This leadership role requires a sense of responsibility for energy and the environment, which is expressed in an intelligent combination of different heating technologies and customised indoor climate solutions.

Hoval also provides personal consultations and comprehensive customer service. With around 2500 employees in 15 companies around the world, Hoval sees itself not as a conglomerate, but as a large family that thinks and acts globally.

Hoval heating and indoor climate solutions are currently exported to more than 50 countries.

## Responsibility for energy and environment

Your Hoval partner

### Liechtenstein

Hoval Aktiengesellschaft  
9490 Vaduz  
+423 399 24 00  
hoval.com

### United Kingdom

Hoval Ltd.  
Newark Notts. NG 24 1JN  
+44 1636 672 711  
hoval.co.uk