

Hoval Belaria® pro

Air/water heat pump

Belaria® pro comfort (8-15)

Belaria® pro compact (8/100/300), (13/100/300)

R290

Natural refrigerant!



Table of contents

■ Description	5
■ Part numbers	7
■ Technical data	15
■ Dimensions	31
■ Engineering	43

Hoval Belaria® pro comfort
Hoval Belaria® pro compact
 Modulating monoblock heat pump for heating and cooling.

Belaria® pro compact (8/100/300) and (13/100/300) additionally with integrated buffer storage tank (100 litres) and calorifier (300 litres) in the indoor unit.

Monoblock heat pump set up outdoors consisting of outdoor unit and indoor unit.

Belaria® pro outdoor unit

- Compact floor-mounted air/water heat pump
- Elegant and extremely quiet outdoor unit
- Casing with sheet metal cladding, powder-coated, colour anthracite (DB703)
- Cooling unit with refrigerant R290
- Integrated components:
 - speed-controlled scroll compressor
 - L-shaped louvre-type evaporator with the Belaria® pro (8,13)
 - straight louvre-type evaporator with the Belaria® pro (15)
 - speed-controlled axial fan with FlowGrid (inlet grille) with the Belaria® pro (8,13), Belaria® pro (15) without FlowGrid
 - plate-type condenser made of stainless steel/copper
 - built-in gas separator with safety valve 2.5 bar
 - condensate drip tray incl. tray heating and condensate trace heater for channelling all the condensate in the outdoor unit, fixed installation, 1" connection
- With cooling function with corresponding hydraulics
- Hydraulic connections behind louvre grille
 - Belaria® pro (8,13): heating connections 1"
 - Belaria® pro (15): heating connections 1¼"
 - Filter ball valve installed in the heat pump return
- Electrical connections behind louvre grille
 - 400 V main power supply, supplied from the indoor unit
 - 230 V control current, supplied from the indoor unit
 - Data cable for bus connection to the indoor unit
- With fitting accessories for fixing the outdoor unit on the ground

Belaria® pro comfort indoor unit

- Compact wall-mounted indoor unit
- Casing made of structured EPP, colour black
- TopTronic® E control installed with TopTronic® E control module
- With WFA-200S automatic heat pump device
- Integrated components:
 - speed-controlled high-efficiency pump
 - flow sensor/heat meter
 - electric heating element 6 kW
 - 3-way switching ball valve for heating/ domestic hot water
- Hydraulic connections at bottom
 - Belaria® pro (8,13): heating connections 1" domestic hot water connection 1"
 - Belaria® pro (15): heating connections 1¼" domestic hot water connection 1¼"



Model range

Belaria® pro comfort

type	Heat output ¹⁾		Cooling capacity ¹⁾		
	35 °C	55 °C	A-7W35 kW	A2W35 kW	A35W18 kW
(8)			2.7-8.3	3.5-8.3	4.9-8.1
(13)			5.0-10.3	5.3-11.8	6.7-11.4
(15)			6.9-13.3	7.1-14.5	7.9-13.6

Belaria® pro compact

type	Heat output ¹⁾		Cooling capacity ¹⁾		
	35 °C	55 °C	A-7W35 kW	A2W35 kW	A35W18 kW
(8/100/300)			2.7-8.3	3.5-8.3	4.9-8.1
(13/100/300)			5.0-10.3	5.3-11.8	6.7-11.4

Energy efficiency class of the compound system with control.

¹⁾ Modulation range

- Electrical connections introduced from bottom
- With fitting accessories for fixing the indoor unit to the wall
- Shut-off ball valves are included in the scope of delivery.

Belaria® pro compact indoor unit

- Compact floor-mounted indoor unit
- Casing made from painted, galvanised sheet steel, colour flame red/brown red (RAL 3000/ RAL 3011)
- TopTronic® E control installed with TopTronic® E control module
- With WFA-200S automatic heat pump device
- Integrated 100 litre buffer storage tank
- Integrated 300 litre calorifier

- Enamel painted calorifier with PU hard-foam insulation, energy efficiency class A, load profile XXL. Maintenance flange and magnesium protection anode built in
- Integrated components:
 - speed-controlled high-efficiency pump
 - flow sensor/heat meter
 - electric heating element 6 kW
 - 3-way switching ball valve for heating/ domestic hot water
 - heating/cooling circuit pump and mixer
- Hydraulic connections top
 - Heating connections 1"
 - Hot water connection 1"
 - Cold water connection 1"
- Electrical connections introduced from top
- Shut-off ball valves are included in the scope of delivery.

TopTronic® E controller

Control panel

- 4.3-inch colour touchscreen
- Heat generator blocking switch for interrupting operation
- Fault signalling lamp
- Mains isolator

TopTronic® E control module

- Simple, intuitive operating concept
- Display of the most important operating states
- Configurable start screen
- Operating mode selection
- Configurable day and week programmes
- Operation of all connected Hoval CAN bus modules
- Commissioning wizard
- Service and maintenance function
- Fault message management
- Analysis function
- Weather display (with HovalConnect option)
- Adaptation of the heating strategy based on the weather forecast (with HovalConnect option)

TopTronic® E basic module heat generator TTE-WEZ

- Integrated control functions for
 - 1 heating/cooling circuit with mixer
 - 1 heating/cooling circuit without mixer
 - 1 hot water charging circuit
 - bivalent and cascade management
- Outdoor sensor
- Immersion sensor (calorifier sensor)
- Contact sensor (flow temperature sensor)
- RAST 5 basic plug set

Options for TopTronic® E controller

- Can be expanded by max. 1 module expansion:
 - module expansion heating circuit or
 - module expansion Universal or
 - module expansion heat balancing
- Can be networked with up to 16 controller modules in total:
 - heating circuit/DHW module
 - solar module
 - buffer module
 - measuring module

Number of additional modules that can be installed in the heat generator:

- Indoor unit Belaria® pro comfort:
- 1 module expansion and 1 controller module
- or**
- 2 controller modules

Indoor unit Belaria® pro compact:

- 1 module expansion and 1 controller module

The supplementary plug set must be ordered in order to use expanded controller functions.

For further information about the TopTronic® E, see "Controls"

EnergyManager PV smart

Feature to increase self-generated power consumption in use with HovalConnect.

If a HovalConnect gateway is used together with the heat pump, the EnergyManager PV smart feature is available. This allows the heat pump to be operated preferentially at times of higher solar radiation. The feature uses online weather data on the current solar radiation for this purpose and can be adjusted by means of an associated threshold value. The self-consumption of electricity from an existing photovoltaic plant is thus increased and the purchase of grid electricity is reduced. This results in a lasting and significant cost-saving potential without further investment costs for the customer.

Delivery

- Outdoor and indoor unit delivered packaged separately
- Belaria® pro comfort sensor kit included loose in the electrical box:
 - outdoor sensor (AF)
 - calorifier sensor (SF1/SF1.1)
 - flow sensor (VF1)
- Sensor set Belaria® pro compact:
 - outdoor sensor (AF) included loose in the electrical box
 - calorifier sensor (SF1/SF1.1) connected to terminal of the indoor unit and mounted
 - flow sensor (VF1) connected to terminal of the indoor unit and mounted
 - heat pump buffer sensor (WPF) connected to terminal of the indoor unit and mounted

On site

- Wall ducts for hydraulic connection lines
- Hydraulic connection lines from the outdoor unit to the inside of the building as far as the indoor unit
- Electrical connection line from the outdoor unit to the indoor unit
- Strip foundation, floor plate

Hoval Integrate

For seamless integration into intelligent home automation and energy management systems. With Hoval Integrate, Hoval heat pumps with TopTronic® E control can be integrated into home automation and energy management systems via open, standardised interfaces. Predefined templates, plugins and Smart Grid integrations simplify implementation and enable intelligent decisions.

Functions such as PV surplus utilisation, dynamic electricity tariffs, grid-friendly control, load management or simple visualisations for analysis purposes can be created and operated individually.

System integrators are free to choose their desired system and benefit from broad compatibility and future-proof sector coupling. Thanks to integrated building automation, end customers benefit from operating cost savings and cross-system functions.

Practical guide videos provide additional support for integration and commissioning – step by step and with a practical orientation.

Notice

Only available in Austria, Germany and Switzerland

Air/water heat pump



Hoval Belaria® pro comfort

Belaria® pro comfort type	Heat output ¹⁾		Cooling capacity ¹⁾
	A-7W35 kW	A2W35 kW	A35W18 kW
(8)	2.7-8.3	3.5-8.3	4.9-8.1
(13)	5.0-10.3	5.3-11.8	6.7-11.4
(15)	6.9-13.3	7.1-14.5	7.9-13.6

¹⁾ Modulation range

Part No.

7019 480
7019 481
7019 482



Hoval Belaria® pro compact

with integrated buffer storage tank (100 litres)
and calorifier (300 litres)

Belaria® pro compact type	Heat output ¹⁾		Cooling capacity ¹⁾
	A-7W35 kW	A2W35 kW	A35W18 kW
(8/100/300)	2.7-8.3	3.5-8.3	4.9-8.1
(13/100/300)	5.0-10.3	5.3-11.8	6.7-11.4

¹⁾ Modulation range

7019 212
7019 213

EnergyManager PV smart

Feature to increase self-generated power consumption in use with HovalConnect.

Further information
see "Description"

Further accessories can be found under the following rubrics:

- Calorifiers/buffer storage tanks:
 - Calorifiers
 - Buffer storage tanks
 - Combination storage tanks
 - Electric heating elements
- Heating armature groups/heating distributors
- Various system components:
 - 2-way and 3-way valves
 - 3-way mixers
 - 2-way and 3-way ball valves
 - Motor drives and butterfly valves
 - Diaphragm pressure expansion tanks
 - Fittings
 - Plate heat exchangers
- Circulating pumps

Notice

Only available in Austria, Germany and Switzerland

Hoval Integrate

For seamless integration into intelligent home automation and energy management systems

Further information

see "Description"

TopTronic® E module expansions
 for TopTronic® E basic module heat generator

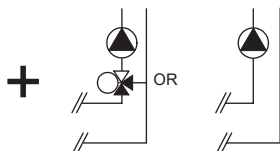
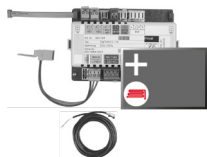

TopTronic® E module expansion heating circuit TTE-FE HK

Expansion to the inputs and outputs of the basic module heat generator or the heating circuit/domestic hot water module for implementing the following functions:

- 1 heating/cooling circuit without mixer or
- 1 heating/cooling circuit with mixer

Consisting of:

- Fitting accessories
- 1 contact sensor ALF/2P/4/T, L = 4.0 m
- Basic plug set FE module

Notice

The supplementary plug set may have to be ordered to implement functions differing from the standard!

Part No.

6034 576

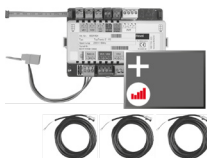

TopTronic® E module expansion heating circuit incl. energy balancing TTE-FE HK-EBZ

Expansion to the inputs and outputs of the basic module heat generator or the heating circuit/domestic hot water module for implementing the following functions:

- 1 heating/cooling circuit without mixer or
- 1 heating/cooling circuit with mixer incl. energy balancing in each case

Consisting of:

- Fitting accessories
- 3 contact sensors ALF/2P/4/T, L = 4.0 m
- Plug set FE module

6037 062

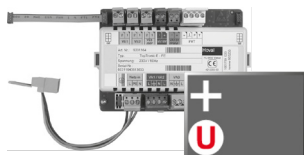

TopTronic® E module expansion Universal TTE-FE UNI

Expansion to the inputs and outputs of a controller module (basic module heat generator, heating circuit/domestic hot water module, solar module, buffer module) for implementing various functions

Consisting of:

- Fitting accessories
- Plug set FE module

6034 575

Further information

see "Controls" section – "Hoval TopTronic® E module expansions" chapter

Notice

Refer to the Hoval System Technology to find which functions and hydraulic arrangements can be implemented.

Accessories for TopTronic® E

Part No.



TopTronic® E controller modules

TTE-HK/WW	TopTronic® E heating circuit/ hot water module	6034 571
TTE-SOL	TopTronic® E solar module	6037 058
TTE-PS	TopTronic® E buffer module	6037 057
TTE-MWA	TopTronic® E measuring module	6034 574



Supplementary plug set

	for basic module heat generator TTE-WEZ	6034 499
	for controller modules and module expansion	6034 503
	TTE-FE HK	



TopTronic® E room control modules

TTE-RBM	TopTronic® E room control modules	
	easy white	6037 071
	comfort white	6037 069
	comfort black	6037 070



Enhanced language package TopTronic® E

	one SD card required per control module	6039 253
	Consisting of the following languages:	
	HU, CS, SL, RO, PL, TR, ES, HR, SR, JA, DA, NL	



HovalConnect

	HovalConnect LAN	6049 496
	HovalConnect WLAN	6049 498
	HovalConnect Modbus	6049 501
	HovalConnect KNX	6049 593

TopTronic® E interface modules

	GLT module 0-10 V	6034 578
--	-------------------	----------

TopTronic® E sensors

AF/2P/K	Outdoor sensor	2055 889
	H x W x D = 80 x 50 x 28 mm	
TF/2P/5/6T	Immersion sensor, L = 5.0 m	2055 888
ALF/2P/4/T	Contact sensor, L = 4.0 m	2056 775
TF/1.1P/2.5S/6T	Collector sensor, L = 2.5 m	2056 776



Bivalent switch

	for various release or switching functions	
	Bivalent switch 1-piece	2056 858
	Bivalent switch 2-piece	2061 826



System casing

	System casing 182 mm	6038 551
	System casing 254 mm	6038 552



TopTronic® E wall casing

WG-190	Wall casing small	6052 983
WG-360	Wall casing medium	6052 984
WG-360 BM	Wall casing medium with control module cut-out	6052 985
WG-510	Wall casing large	6052 986
WG-510 BM	Wall casing large with control module cut-out	6052 987



Further information
 see "Controls"

Accessories for Belaria® pro (8,13)



HP line insul. WA-HP 125-32 with connector set

Flexible, pre-insulated and self-compensating line with two heating pipes and two empty pipes.

With connector set consisting of:

- 4 clamping couplings WA DN 32 1" ET 32 x 2.9 mm
 - 1 end cap WA-HP 125-32
 - 1 protective cap WA-HP 125-32
 - 1 protective cap set WA-HP protection tube DN 25
 - 1 split ring seal 125/200
- Outside diameter: 125 mm
 Fluid pipes: 2 x 32 mm / 2.9 mm (DN 25)
 Outside diameter empty pipe 1: 32 mm
 Outside diameter empty pipe 2: 25 mm
 Bending radius: 0.3 m
 Operating temperature: -10 ... 85 °C
 Maximum temperature: 95 °C
 Nominal pressure: 6 bar

Dimension inside/outside	Line length m	Part No.
DN 25/32	5	6065 263
DN 25/32	10	6065 264
DN 25/32	15	6065 265
DN 25/32	20	6065 266
DN 25/32	25	6065 267



Lining pipe DN 200 D210/D200 x 400

for HP line insulated WA-HP
 Lining pipe for feeding the HP lines through ceilings, walls and floors.
 Suitable for walling in and cementing in.
 Lining pipe material: PVC
 Outer Ø: 210 mm
 Internal Ø: 200 mm
 Length: 400 mm

2080 584



Connection set AS25-BPA

for Belaria® pro (8,13)
 Flexible connection line that can be shortened for connecting flow and return within the heat pump
 Consisting of:

- 1 3.0 m corrugated pipe DN 20 insulated
- Insulation 20/28 with PE protective foil
- 3 angle screw connections IT/ET 1"
- 4 union nuts 1"
- 2 support rings 1"
- Flat seals NBR

6063 098

Notice

In cooling applications, the piping and fittings must be insulated accordingly.



Adhesive tape IKB

for thermal insulation made of EPDM
 Thickness: 3 mm
 Width: 50 mm
 Roll: 15 m

2023 563

Accessories for Belaria® pro (15)



HP line insul. WA-HP 160-40 with connector set

Flexible, pre-insulated and self-compensating line with two heating pipes and two empty pipes.

With connector set consisting of:

- 4 clamping couplings WA DN 40 1¼" ET 40 x 3.7 mm
 - 1 end cap WA-HP 160-40
 - 1 protective cap WA-HP 160-40
 - 1 protective cap set WA-HP protection tube DN 32
 - 1 split ring seal 160/250
- Outside diameter: 160 mm
Fluid pipes: 2 x 40 mm / 3.7 mm (DN 32)
Outside diameter empty pipe 1: 32 mm
Outside diameter empty pipe 2: 32 mm
Bending radius: 0.6 m
Operating temperature: -10 ... 85 °C
Maximum temperature: 95 °C
Nominal pressure: 6 bar

Dimension inside/outside	Line length m	Part No.
DN 32/40	5	6065 268
DN 32/40	10	6065 269
DN 32/40	15	6065 270
DN 32/40	20	6065 271
DN 32/40	25	6065 272



Lining pipe DN 250 D280/D250 x 400

for HP line insulated WA-HP
Lining pipe for feeding the HP lines through ceilings, walls and floors. Suitable for walling in and cementing in.
Lining pipe material: PVC
Outer Ø: 280 mm
Internal Ø: 250 mm
Length: 400 mm

2087 112



Connection set AS32-BPA

for Belaria® pro (15)

Flexible connection line that can be shortened for connecting flow and return within the heat pump

Consisting of:

- 1 3.0 m corrugated pipe DN 25 insulated
- Insulation 20/35 with PE protective foil
- 3 angle screw connections IT/ET 1¼"
- 4 union nuts 1¼"
- 2 support rings 1¼"
- Flat seals NBR

6063 099

Notice

In cooling applications, the piping and fittings must be insulated accordingly.



Adhesive tape IKB

for thermal insulation made of EPDM
Thickness: 3 mm
Width: 50 mm
Roll: 15 m

2023 563

Accessories

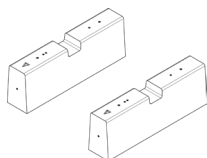

Concrete base set BSW02-FU

for Belaria® pro (8-15) and UltraSource® B (8,11)

for safe installation of an outdoor unit on a firm base

Consisting of:

2 concrete bases with cast-in fastening sleeves M8 and M10

Dimensions (H x W x D):

250 x 750 x 150 mm

Weight: 2 pieces of 57 kg

Part No.

6054 856

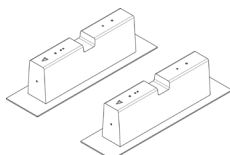

Concrete base set BSW02-FD

for Belaria® pro (8-15) and UltraSource® B (8,11)

for safe installation of an outdoor unit on the flat roof.

Consisting of:

2 concrete bases with cast-in fastening sleeves M8 and M10

Protective mats with aluminium lining

Dimensions (H x W x D):

250 x 750 x 150 mm

Weight: 2 pieces of 57 kg

6054 857

Notice

In a flat roof installation, all standards concerning statics, wind load and access to roofs must be complied with.

Further information

see "Engineering" chapter

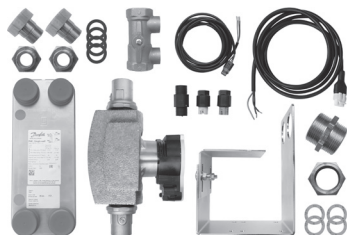

Separation system of heat pump

for separation of heating circuit and primary heating circuit.

Consisting of:

- Plate heat exchanger (soldered)

Dimensioning ΔT : 3 K

- Wall installation connection bracket

- Connection screw fittings

- Pump incl. thermal insulation shell, mains and signal cable and connection screw fittings

- Filling/flushing unit

Type	TS	Number of plates
------	----	------------------

Belaria® pro comfort (8), pro compact (8/100/300)	25-30	30
---	-------	----

6063 264

Belaria® pro comfort (13), pro compact (13/100/300)	25-40	40
---	-------	----

6063 265

Belaria® pro comfort (15)	32-50	50
---------------------------	-------	----

6063 266

Diaphragm pressure expansion tanks and frost protection must be ordered separately.



HA group HA 25-2-WP

for Belaria® compact (8,13/100/300)

Direct heating/cooling circuit without mixer for mounting in Belaria® pro compact indoor unit

6062 554



Correx® impressed current anode

for Belaria® pro compact (8,13/100/300)

for long-term corrosion protection for installation in the enamelled calorifier with built-in socket.

6051 882

Only either a Correx® impressed current anode or a magnesium anode is allowed to be used.

Accessories



Safety set SGK15-PN3 IT 1" insulated
Safety group made of composite material (glass fiber reinforced polyamide) complete with safety valve (3 bar), quick air vent and pressure gauge
Connection IT 1" (ISO228-1) with insulating caps
Medium temperature range: 5 ... 90 °C
Setting (pressure): 3 bar
Area of application up to 50 kW

6063 905



Differential pressure relief valve DN 20
for free installation with flexible centre distance
Connections at both ends 1" ET
Operating pressure: max. 10 bar
Operating temperature: max. 120 °C
Setting range: 0.05-0.5 bar
Length: 93 mm
Casing made of brass with setting handle made of plastic

240 554



Vibration decoupler
for reducing structure-borne noise from heat pumps indoors, cannot be shortened
Consisting of:
- 1 vibration decoupler insulated for heating and brine side flat-sealing with union nut
- 2 flat seals
Nominal pressure: PN 10

Dimension	Connection inches	Nominal length mm
DN 25	1"	300
DN 25	1"	500
DN 25	1"	1000
DN 32	1¼"	300
DN 32	1¼"	500
DN 32	1¼"	1000

2082 222
2082 223
2080 794
2082 224
2082 225
2080 796

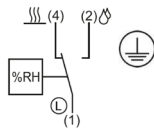

Dewpoint monitor (TPW)
for monitoring the formation of condensation in a compartment, with gold contacts, can be installed as required for pipes up to Ø 50 mm
The installation location must be selected in such a way that a representative humidity measurement is guaranteed i.e. the room air must flow unhindered through the slots in the housing to the measuring element inside the casing.
The TPW does not require supply voltage or auxiliary energy and should be mounted in an air flow with an air velocity of at least 0.2 m/s.
Control range: 50 ... 90 % RH
Max. switch power: 100 mA/250 V AC
Operating temperature: 0 ... 60 °C
Dimensions: 85 x 55 x 33 mm
Weight: approx. 92 g
Type of protection: IP20

2070 911

Notice

The dewpoint monitor is the only safety equipment in cooling systems and is always mandatory, to prevent damage caused by condensing water in surface cooling systems (floor, wall, ceiling cooling)!
This applies to both active and passive cooling systems.

Services



Services and associated scope of services
see separate catalogue "Hoval Services"

Commissioning by Hoval customer service is a prerequisite for warranty/guarantee activation.

Part No.

Belaria® pro comfort (8-15)

Belaria® pro compact (8/100/300,13/100/300)

Type		(8) (8/100/300)	(13) (13/100/300)	(15)
• Energy efficiency class of the compound system with control ¹⁾ (A+++ →	35 °C/55 °C	A+++/A+++	A+++/A+++	A+++/A+++
• Energy efficiency class load profile XXL (A+ → F)	Domestic hot water	-/A	-/A	-
• Room heating energy efficiency "moderate climate" 35 °C η _S	%	207	203	221
• Room heating energy efficiency "moderate climate" 55 °C η _S	%	154	154	162
• Water heating energy efficiency consumption profile/η _{wh} 35 °C/55 °C	-/%	XXL/105	XXL/101	-/-
• Seasonal coefficient of performance moderate climate 35 °C/55 °C	SCOP	5.3/3.9	5.2/4.0	5.6/4.1
• Seasonal coefficient of performance heating A35W18 ²⁾	SEER	4.5	5.3	4.7
• Seasonal coefficient of performance heating A35W7 ²⁾	SEER	2.5	2.9	3.0
Max./min. performance data heating and cooling in acc. with EN 14511				
• Max. heat output A2W35	kW	8.3	11.8	14.5
• Max. heat output A-7W35	kW	8.3	10.3	13.3
• Min. heat output A15W35	kW	4.5	5.4	7.7
• Max. cooling capacity A35W18	kW	8.1	11.4	13.6
• Max. cooling capacity A35W7	kW	6.4	8.8	10.0
• Min. cooling capacity A35W18	kW	4.9	6.7	7.9
Nominal output data heating in acc. with EN 14511				
• Nominal heat output A2W35	kW	3.5	5.3	8.7
• Coefficient of performance A2W35	COP	4.6	4.6	4.7
• Nominal heat output A7W35	kW	4.1	5.9	9.8
• Coefficient of performance A7W35	COP	5.4	5.5	5.6
• Nominal heat output A-7W35	kW	4.0	5.3	8.5
• Coefficient of performance A-7W35	COP	3.4	3.5	3.5
Nominal output data cooling in acc. with EN 14511				
• Nominal cooling capacity A35W18	kW	6.3	9.7	11.6
• Energy efficiency ratio A35W18	EER	4.9	4.6	4.6
• Nominal cooling capacity A35W7	kW	4.4	6.5	7.5
• Energy efficiency ratio A35W7	EER	3.5	3.2	3.0
Sound data				
• Max. sound power level outdoor unit, day operation	dB(A)	55	57	55
• Sound power level EN 12102 outdoor unit whisper mode	dB(A)	44	49	48
• Sound power level EN 12102 outdoor unit ³⁾	dB(A)	46	51	50
• Sound pressure level 5 m ^{3), 4)}	dB(A)	27	32	31
• Sound pressure level 10 m ^{3), 4)}	dB(A)	21	26	25
Hydraulic data				
• Max. flow temperature	°C	70	70	70
• Max. flow rate heating side with A7W35, ΔT 6 K	m ³ /h	1.2	1.8	2.3
• Nominal flow rate heating side with A7W35, ΔT 5 K	m ³ /h	0.7	1	1.7
• Max. flow rate heating side with A35W7, ΔT 4 K	m ³ /h	2.5	3.1	3.6
• Residual overpressure of heating pump at nominal flow A7W35, ΔT 5 K	kPa	69	81	49
• Residual overpressure of heating pump at max. flow rate A35W7, ΔT 4 K	kPa	53	62	32
• Max. operating pressure on the heating side ¹¹⁾	bar	2.5	2.5	2.5
• Max. operating pressure domestic hot water side	bar	10	10	-
• Flow/return connection heating	G	1"	1"	1¼"
• Cold water connection Belaria® pro comfort	R	1"	1"	1¼"
• Cold/hot water connection Belaria® pro compact	R	1"/1"	1"/1"	-
• Nominal air volume outdoor unit (A7W35 and nominal rotation speed)	m ³ /h	2000	3000	4900
• Max. air volume outdoor unit (A7W35 and max. speed of rotation)	m ³ /h	2560	3580	5900
• Hydraulic connection line, max. length/dimension inside ⁵⁾	m/DN	30/25	30/25	30/32

Type		(8) (8/100/300)	(13) (13/100/300)	(15)
Cooling technical data				
• Compressor		modulating	modulating	modulating
• Refrigerant		R290	R290	R290
• Refrigerant filling quantity	kg	1.2	1.8	2.8
• Compressor oil type		PZ46M	PZ46M	PZ46M
• Compressor oil filling quantity	l	0.9	0.9	0.9
Electrical data				
• Electrical connection of compressor	V/Hz	3~400/50	3~400/50	3~400/50
• Electrical connection of controller	V/Hz	1~230/50	1~230/50	1~230/50
• Electrical connection of electric heating element	V/Hz	3~400/50	3~400/50	3~400/50
• Max. heat pump operating current	A	8.5	9.5	12.9
• Max. compressor operating current	A	8.5	9.5	12.9
• Max. fan operating current	A	0.3	0.6	0.4
• Max. electric heating element operating current	A	8.7	8.7	8.7
• Max. output of electric heating element	kW	6.0	6.0	6.0
• Max. power consumption of heat pump	kW	5.2	5.8	7.9
• Max. fan power consumption	W	70	140	84
• Max. starting current heat pump I _A	A	8.5	9.5	12.9
• Power factor (cos φ)		0.88	0.88	0.88
• External protection main current	A	C/K 13	C/K 13	C/K 13
• External protection control current	A	B/Z 13	B/Z 13	B/Z 13
• External protection electric heating element	A	B/Z 13	B/Z 13	B/Z 13
• Fault-current circuit breaker		RCCB type B, IΔn ≥ 300 mA		
• Recommended cable		Cu 5 x 1.5 mm ²		
• Max. electrical output	kW	4.8 at A-10W70	6.8 at A2W70	6.2 at A-7W70
• Active power of heat pump	kW	4.6	5.1	7.0
• Max. operating voltage U _b	V	3~400	3~400	3~400
• Max. operating current I _b	A	8.5	9.5	12.9
• Max. inverter output current	A	18.0	18.0	18.0
• Pulse count		3	3	3
• Max. switching frequency per hour/day at t _n 0 °C	n	3/72	3/72	3/72
• Continuous load changes			No	
• Starting up under load			No	
• Feedback into the power system			No	
• Power factor correction			No	
• Starting up assistance			Output control	
• Type of starting up assistance			Frequency converter	
• Frequency converter			60-360 Hz (20-120 rps)	
• Starting current/nominal current ratio			1.00	
Dimensions/weight of outdoor unit				
• Dimensions (H x W x D)	mm	954x1575x791		1432x1575x791
• Weight	kg	287	300	350
• Protection class		IP24	IP24	IP24
Dimensions/weight of indoor unit Belaria® pro comfort				
• Dimensions (H x W x D)	mm	1005x550x280		
• Weight	kg	30	30	30
• Protection class		IP20	IP20	IP20
Dimensions/weight of indoor unit Belaria® pro compact				
• Dimensions (H x W x D)	mm	1930x790x790		-
• Tilting dimension	mm	2085	2085	-
• Weight	kg	360	360	-
• Protection class		IP20	IP20	-
• Dimensions without cladding (H x W x D) ⁶⁾	mm	1930x783x785		-

Type		(8) (8/100/300)	(13) (13/100/300)	(15)
Hot water storage tank Belaria® pro compact				
• Volume ⁷⁾	dm ³	327	327	-
• Heating surface of heating coil	m ²	4.0	4.0	-
• Heating water of heating coil	dm ³	32	32	-
• Maximum storage tank temperature with electric heating element	°C	75	75	-
• Max. operating temperature	°C	80	80	-
• Output capacity at 40 °C and storage tank temperature at 60 °C ⁸⁾	l	570	570	-
• Output capacity at 40 °C and storage tank temperature at 65 °C ⁹⁾	l	634	634	-
• Output capacity at 40 °C and storage tank temperature at 75 °C ¹⁰⁾	l	745	745	-
• Output capacity at 46 °C and storage tank temperature at 60 °C ⁸⁾	l	469	469	-
• Output capacity at 46 °C and storage tank temperature at 65 °C ⁹⁾	l	522	522	-
• Output capacity at 46 °C and storage tank temperature at 75 °C ¹⁰⁾	l	613	613	-
Buffer storage tank Belaria® pro compact				
• Volume ⁷⁾	dm ³	93	93	-

¹⁾ Related to moderate climate

²⁾ EN 14825

³⁾ The sound values apply with a clean evaporator. These values are temporarily exceeded before defrosting.

⁴⁾ The sound pressure levels indicated apply if the outdoor unit is placed at a building façade. These values are reduced by 3 dB if the outdoor unit is free-standing. With installation in a corner, the sound pressure level increases by 3 dB.

⁵⁾ If the Belaria® pro is operated without a buffer storage tank connected in parallel, the customer must assess whether the next larger pipe dimension is more suitable due to the pressure drop.

Hydraulic connection lines DN 40 are listed in the Belaria® pro (20,25) chapter.

⁶⁾ The removal of the cladding sections is time-consuming.

⁷⁾ Storage capacity incl. heating coil

⁸⁾ 12 °C cold water temperature/60 °C lower storage tank temperature (heat pump)

⁹⁾ 12 °C cold water temperature/65 °C lower storage tank temperature (heat pump + electric heating element)

⁹⁾ 12 °C cold water temperature/75 °C lower storage tank temperature (heat pump + electric heating element)

¹¹⁾ Maximum operating pressure of the system without isolating system 2.5 bar, because the outdoor unit is protected with 2.5 bar. Provide general protection of the system in the building with 3.0 bar.

An isolating system must be provided for system pressures of 2.5 bar or more.

Using a fault-current circuit breaker RCCB type B, IΔn ≥ 300 mA must be clarified based on the regulations of the country in question.

Diagrams of areas of application

Heating and domestic hot water

Belaria® pro comfort (8-15)
Belaria® pro compact (8/100/300), (13/100/300)

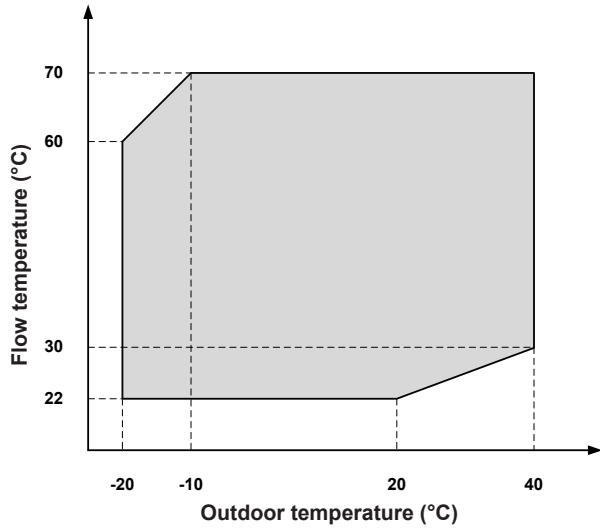

Area of application of the heat pump for heating/domestic hot water (Belaria® pro comfort and pro compact)

Cooling

Belaria® pro comfort (8-15)
Belaria® pro compact (8/100/300), (13/100/300)

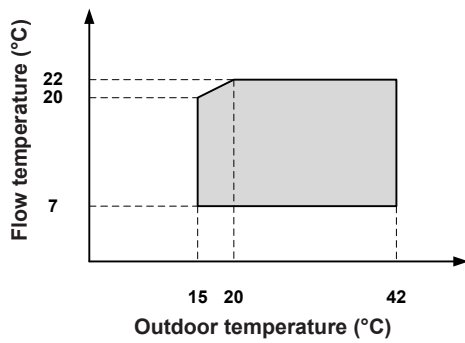

Area of application of the heat pump for cooling (Belaria® pro comfort and pro compact)

Performance data – heating

Maximum heat output allowing for defrosting losses

Belaria® pro comfort (8), compact (8/100/300)

Data according to EN 14511

Heat output – $t_{VL} 35\text{ °C}$

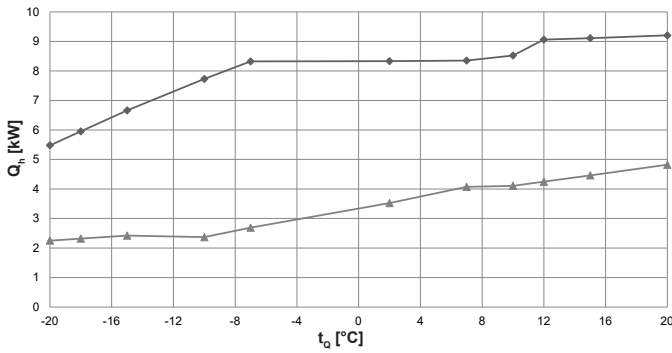

Coefficient of performance – $t_{VL} 35\text{ °C}$

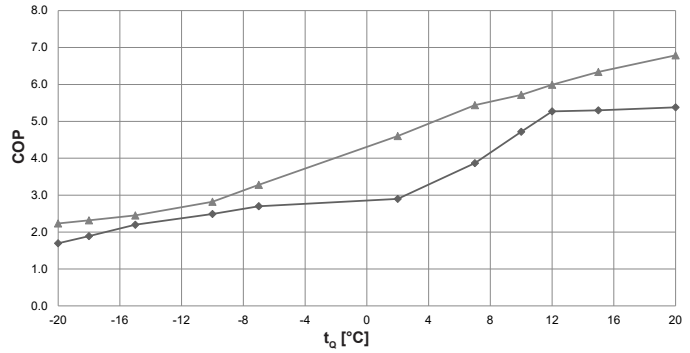

Heat output – $t_{VL} 45\text{ °C}$

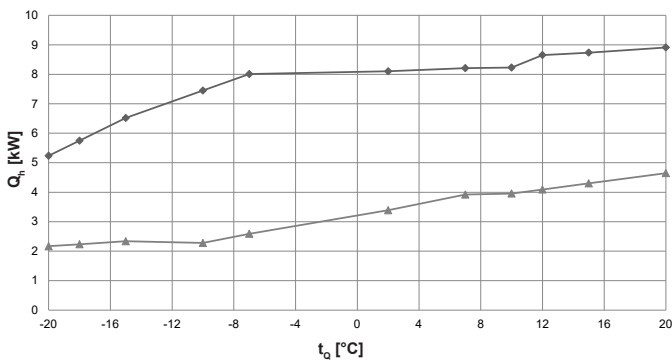

Coefficient of performance – $t_{VL} 45\text{ °C}$

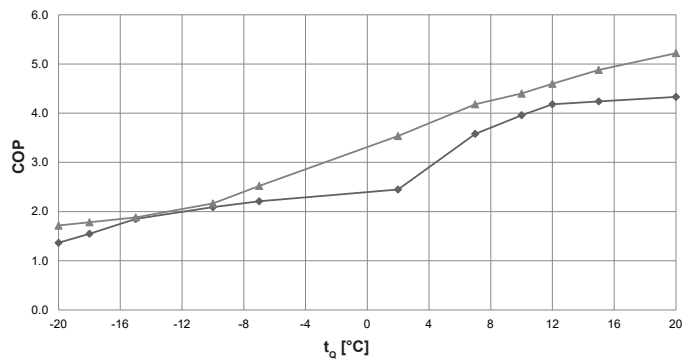

Heat output – $t_{VL} 55\text{ °C}$

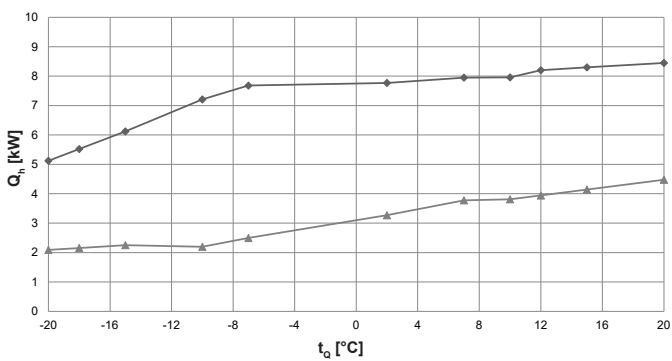

Coefficient of performance – $t_{VL} 55\text{ °C}$

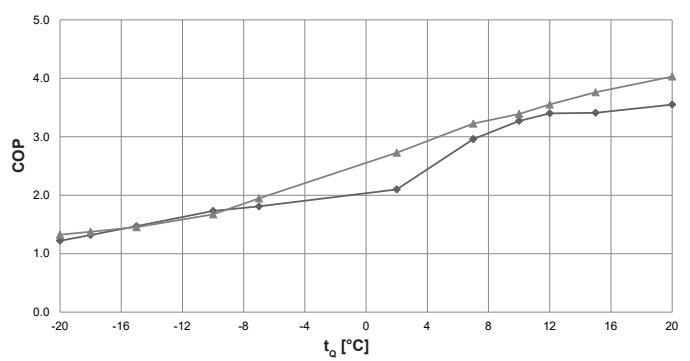

Heat output – $t_{VL} 70\text{ °C}$

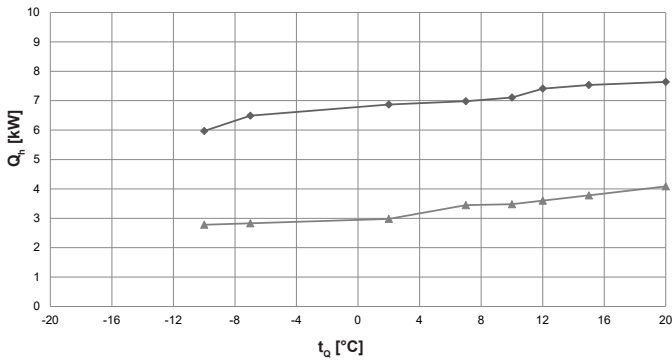

Coefficient of performance – $t_{VL} 70\text{ °C}$

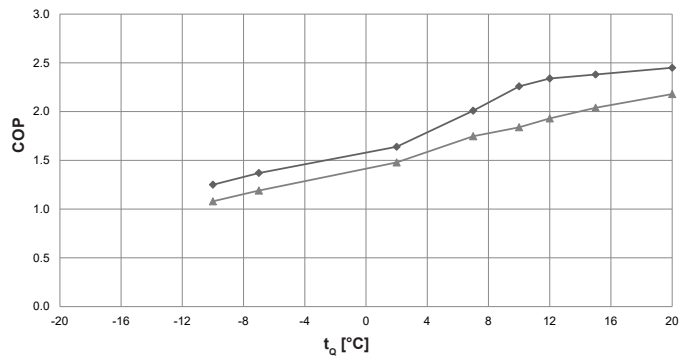

t_{VL} = heating flow temperature (°C)

t_o = source temperature (°C)

Q_h = heat output (kW), measured in accordance with standard EN 14511

COP = Coefficient of Performance for the overall unit in accordance with standard EN 14511

◆ Maximum output

▲ Minimum output

Performance data – heating

Belaria® pro comfort (8), compact (8/100/300)

Data according to EN 14511

t_{VL} °C	t_o °C	Maximum output			Minimum output		
		Q_h kW	P kW	COP	Q_h kW	P kW	COP
35	-20	5.5	3.2	1.7	2.3	1.0	2.2
	-18	6.0	3.1	1.9	2.3	1.0	2.3
	-15	6.7	3.0	2.2	2.4	1.0	2.5
	-10	7.7	3.1	2.5	2.4	0.8	2.8
	-7	8.3	3.1	2.7	2.7	0.8	3.3
	2	8.3	2.9	2.9	3.5	0.8	4.6
	7	8.4	2.2	3.9	4.1	0.7	5.4
	10	8.5	1.8	4.7	4.1	0.7	5.7
	12	9.1	1.7	5.3	4.2	0.7	6.0
	15	9.1	1.7	5.3	4.5	0.7	6.3
20	9.2	1.7	5.4	4.8	0.7	6.8	
45	-20	5.2	3.8	1.4	2.2	1.3	1.7
	-18	5.8	3.7	1.6	2.2	1.3	1.8
	-15	6.5	3.5	1.9	2.3	1.2	1.9
	-10	7.5	3.6	2.1	2.3	1.1	2.2
	-7	8.0	3.6	2.2	2.6	1.0	2.5
	2	8.1	3.3	2.5	3.4	1.0	3.5
	7	8.2	2.3	3.6	3.9	0.9	4.2
	10	8.2	2.1	4.0	4.0	0.9	4.4
	12	8.7	2.1	4.2	4.1	0.9	4.6
	15	8.7	2.1	4.2	4.3	0.9	4.9
20	8.9	2.1	4.3	4.6	0.9	5.2	
50	-20	5.2	4.0	1.3	2.1	1.4	1.5
	-18	5.6	3.9	1.4	2.2	1.4	1.6
	-15	6.3	3.8	1.7	2.3	1.4	1.7
	-10	7.3	3.8	1.9	2.2	1.2	1.9
	-7	7.8	3.9	2.0	2.5	1.1	2.2
	2	7.9	3.5	2.3	3.3	1.1	3.1
	7	8.1	2.5	3.3	3.9	1.0	3.7
	10	8.1	2.2	3.6	3.9	1.0	3.9
	12	8.4	2.2	3.8	4.0	1.0	4.1
	15	8.5	2.2	3.8	4.2	1.0	4.3
20	8.7	2.2	3.9	4.6	1.0	4.6	
55	-20	5.1	4.2	1.2	2.1	1.6	1.3
	-18	5.5	4.2	1.3	2.2	1.6	1.4
	-15	6.1	4.2	1.5	2.3	1.5	1.5
	-10	7.2	4.2	1.7	2.2	1.3	1.7
	-7	7.7	4.2	1.8	2.5	1.3	1.9
	2	7.8	3.7	2.1	3.3	1.2	2.7
	7	8.0	2.7	3.0	3.8	1.2	3.2
	10	8.0	2.4	3.3	3.8	1.1	3.4
	12	8.2	2.4	3.4	3.9	1.1	3.6
	15	8.3	2.4	3.4	4.1	1.1	3.8
20	8.5	2.4	3.6	4.5	1.1	4.0	

t_{VL} = heating flow temperature (°C)

t_o = source temperature (°C)

Q_h = heat output (kW), measured in accordance with standard EN 14511

P = power consumption for the overall unit (kW)

COP = Coefficient of Performance for the overall unit in accordance with standard EN 14511

Further performance data – heating
see next page

Observe daily power interruptions!
see “Engineering heat pumps general”

Performance data – heating

Belaria® pro comfort (8), compact (8/100/300)

Data according to EN 14511

t_{VL} °C	t_Q °C	Maximum output			Minimum output		
		Q_h kW	P kW	COP	Q_h kW	P kW	COP
60	-20	5.1	4.6	1.1	-	-	-
	-18	5.4	4.6	1.2	-	-	-
	-15	5.8	4.6	1.3	-	-	-
	-10	6.7	4.5	1.5	2.1	1.5	1.4
	-7	7.4	4.5	1.6	2.4	1.5	1.7
	2	7.6	3.9	1.9	3.2	1.4	2.3
	7	7.6	3.0	2.6	3.7	1.3	2.7
	10	7.8	2.7	2.8	3.7	1.3	2.9
	12	8.0	2.6	3.0	3.8	1.3	3.0
	15	8.1	2.7	3.0	4.0	1.3	3.2
70	20	8.2	2.6	3.2	4.4	1.3	3.4
	-20	-	-	-	-	-	-
	-18	-	-	-	-	-	-
	-15	-	-	-	-	-	-
	-10	6.0	4.8	1.3	2.8	2.6	1.1
	-7	6.5	4.7	1.4	2.8	2.4	1.2
	2	6.9	4.2	1.6	3.0	2.0	1.5
	7	7.0	3.5	2.0	3.4	2.0	1.7
	10	7.1	3.1	2.3	3.5	1.9	1.8
	12	7.4	3.2	2.3	3.6	1.9	1.9
15	7.5	3.2	2.4	3.8	1.9	2.0	
20	7.6	3.1	2.5	4.1	1.9	2.2	

t_{VL} = heating flow temperature (°C)

t_Q = source temperature (°C)

Q_h = heat output (kW), measured in accordance with standard EN 14511

P = power consumption for the overall unit (kW)

COP = Coefficient of Performance for the overall unit in accordance with standard EN 14511

Observe daily power interruptions!
see "Engineering heat pumps general"

Performance data – heating

Maximum heat output allowing for defrosting losses

Belaria® pro comfort (13), compact (13/100/300)

Data according to EN 14511

Heat output – $t_{VL} 35\text{ °C}$

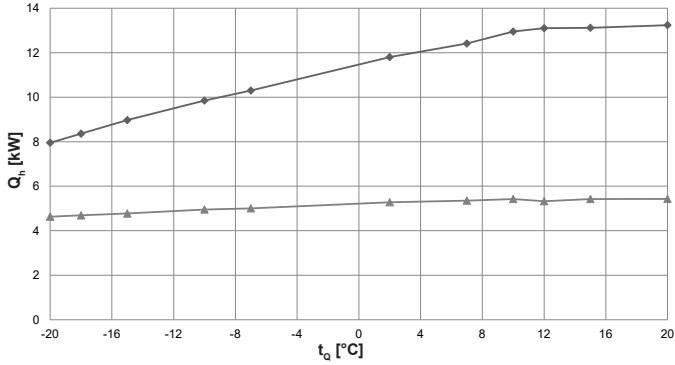

Coefficient of performance – $t_{VL} 35\text{ °C}$

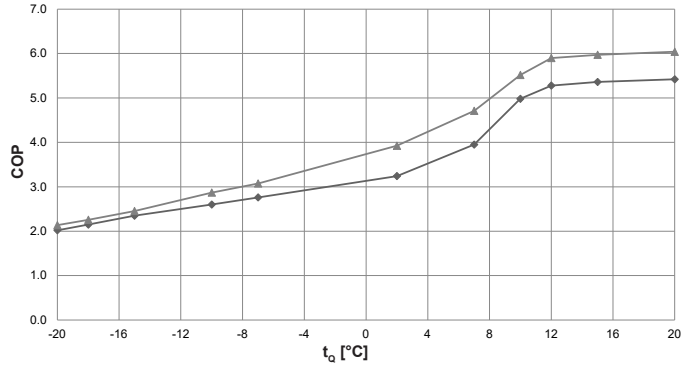

Heat output – $t_{VL} 45\text{ °C}$

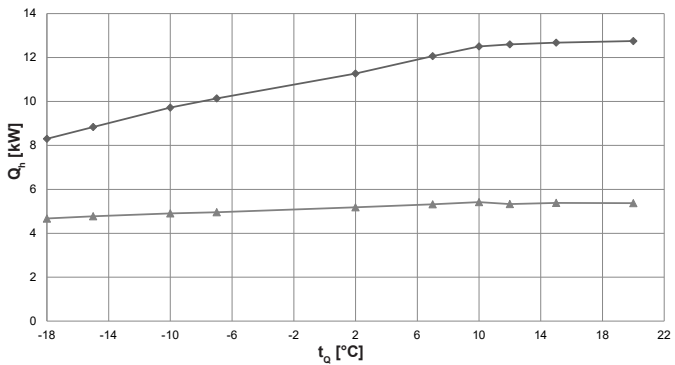

Coefficient of performance – $t_{VL} 45\text{ °C}$

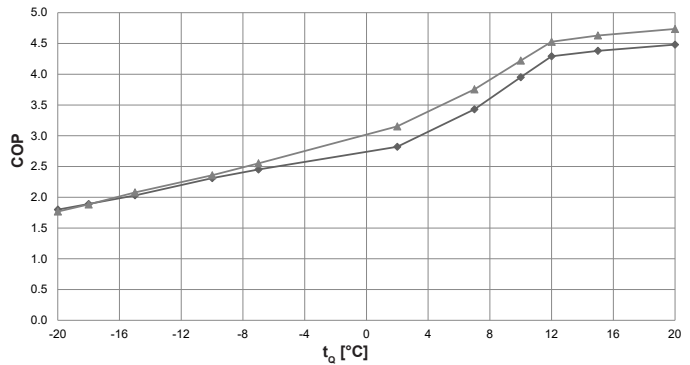

Heat output – $t_{VL} 55\text{ °C}$

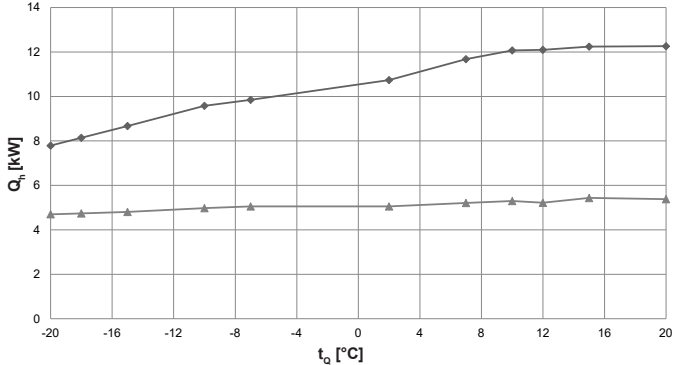

Coefficient of performance – $t_{VL} 55\text{ °C}$

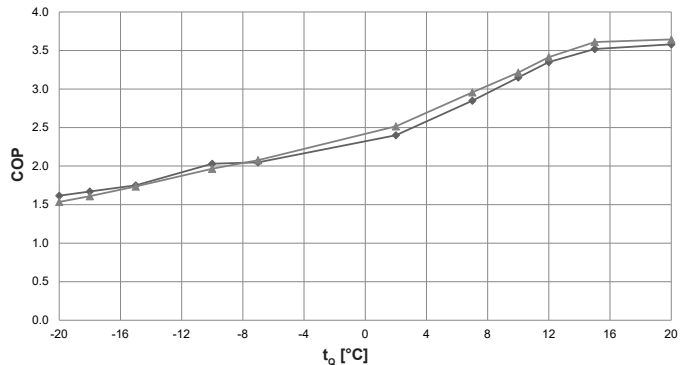

Heat output – $t_{VL} 70\text{ °C}$

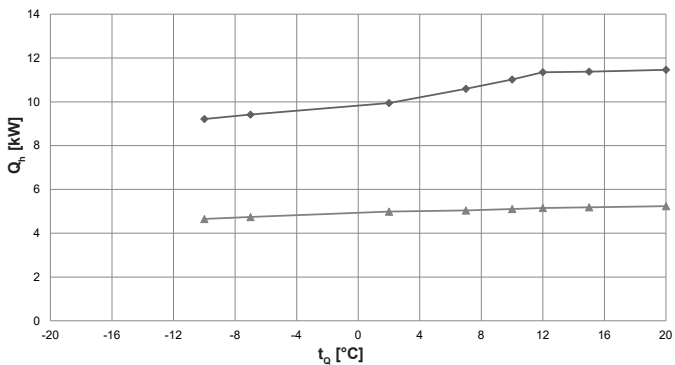

Coefficient of performance – $t_{VL} 70\text{ °C}$

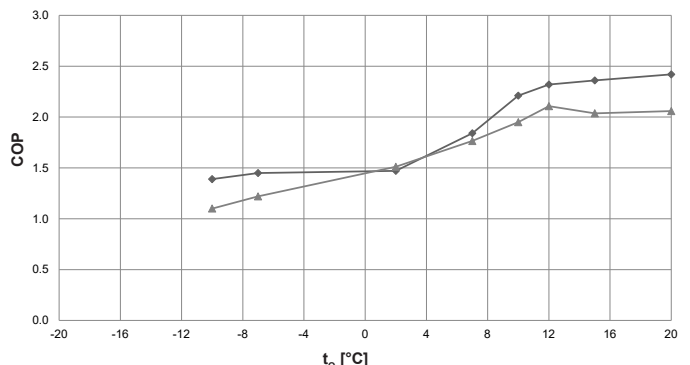

t_{VL} = heating flow temperature (°C)

t_{CS} = source temperature (°C)

Q_h = heat output (kW), measured in accordance with standard EN 14511

COP = Coefficient of Performance for the overall unit in accordance with standard EN 14511

◆ Maximum output
 ▲ Minimum output

Performance data – heating

Belaria® pro comfort (13), compact (13/100/300)

Data according to EN 14511

t_{VL} °C	t_Q °C	Maximum output			Minimum output		
		Q_h kW	P kW	COP	Q_h kW	P kW	COP
35	-20	8.0	3.9	2.0	4.6	2.2	2.1
	-18	8.4	3.9	2.2	4.7	2.1	2.3
	-15	9.0	3.8	2.4	4.8	1.9	2.5
	-10	9.9	3.8	2.6	5.0	1.7	2.9
	-7	10.3	3.7	2.8	5.0	1.6	3.1
	2	11.8	3.6	3.2	5.3	1.3	3.9
	7	12.4	3.1	4.0	5.4	1.1	4.7
	10	13.0	2.6	5.0	5.4	1.0	5.5
	12	13.1	2.5	5.3	5.3	0.9	5.9
	15	13.1	2.4	5.4	5.4	0.9	6.0
45	20	13.2	2.4	5.4	5.4	0.9	6.0
	-20	7.9	4.4	1.8	4.6	2.6	1.8
	-18	8.3	4.4	1.9	4.7	2.5	1.9
	-15	8.8	4.4	2.0	4.8	2.3	2.1
	-10	9.7	4.2	2.3	4.9	2.1	2.4
	-7	10.1	4.1	2.5	5.0	1.9	2.6
	2	11.3	4.0	2.8	5.2	1.7	3.2
	7	12.1	3.5	3.4	5.3	1.4	3.8
	10	12.5	3.2	4.0	5.4	1.3	4.2
	12	12.6	2.9	4.3	5.3	1.2	4.5
50	15	12.7	2.9	4.4	5.4	1.2	4.6
	20	12.8	2.8	4.5	5.4	1.1	4.7
	-20	7.9	4.6	1.7	4.7	2.8	1.7
	-18	8.2	4.6	1.8	4.7	2.7	1.7
	-15	8.8	4.6	1.9	4.8	2.5	1.9
	-10	9.6	4.4	2.2	4.9	2.3	2.2
	-7	10.0	4.4	2.3	5.0	2.2	2.3
	2	11.0	4.2	2.6	5.1	1.8	2.8
	7	11.9	3.8	3.1	5.3	1.6	3.4
	10	12.3	3.5	3.6	5.4	1.4	3.7
55	12	12.4	3.2	3.8	5.3	1.3	4.0
	15	12.5	3.2	4.0	5.4	1.3	4.1
	20	12.5	3.1	4.0	5.4	1.3	4.2
	-20	7.8	4.8	1.6	4.7	3.1	1.5
	-18	8.1	4.9	1.7	4.7	2.9	1.6
	-15	8.7	5.0	1.8	4.8	2.8	1.7
	-10	9.6	4.7	2.0	5.0	2.5	2.0
	-7	9.9	4.8	2.1	5.1	2.4	2.1
	2	10.7	4.5	2.4	5.1	2.0	2.5
	7	11.7	4.1	2.9	5.2	1.8	3.0
	10	12.1	3.8	3.2	5.3	1.6	3.2
	12	12.1	3.6	3.4	5.2	1.5	3.4
	15	12.2	3.5	3.5	5.4	1.5	3.6
	20	12.3	3.4	3.6	5.4	1.5	3.6

t_{VL} = heating flow temperature (°C)

t_Q = source temperature (°C)

Q_h = heat output (kW), measured in accordance with standard EN 14511

P = power consumption for the overall unit (kW)

COP = Coefficient of Performance for the overall unit in accordance with standard EN 14511

Further performance data – heating
see next page

Observe daily power interruptions!
see "Engineering heat pumps general"

Performance data – heating

Belaria® pro comfort (13), compact (13/100/300)

Data according to EN 14511

t_{VL} °C	t_o °C	Maximum output			Minimum output		
		Q_h kW	P kW	COP	Q_h kW	P kW	COP
60	-20	7.7	5.1	1.5	-	-	-
	-18	8.1	5.2	1.6	-	-	-
	-15	8.6	5.3	1.6	-	-	-
	-10	9.4	5.3	1.8	5.0	2.8	1.8
	-7	9.7	5.2	1.9	5.0	2.7	1.9
	2	10.5	5.1	2.0	5.0	2.3	2.2
	7	11.5	4.5	2.6	5.2	2.0	2.6
	10	11.9	4.3	2.8	5.2	1.9	2.8
	12	11.9	4.1	2.9	5.2	1.8	3.0
	15	12.0	3.9	3.1	5.2	1.7	3.1
70	20	12.0	3.8	3.1	5.3	1.7	3.1
	-20	-	-	-	-	-	-
	-18	-	-	-	-	-	-
	-15	-	-	-	-	-	-
	-10	9.2	6.6	1.4	4.7	4.2	1.1
	-7	9.4	6.5	1.5	4.7	3.9	1.2
	2	9.9	6.8	1.5	5.0	3.3	1.5
	7	10.6	5.8	1.8	5.0	2.9	1.8
	10	11.0	5.0	2.2	5.1	2.6	2.0
	12	11.4	4.9	2.3	5.2	2.4	2.1
15	11.4	4.8	2.4	5.2	2.5	2.0	
20	11.5	4.7	2.4	5.2	2.5	2.1	

t_{VL} = heating flow temperature (°C)

t_o = source temperature (°C)

Q_h = heat output (kW), measured in accordance with standard EN 14511

P = power consumption for the overall unit (kW)

COP = Coefficient of Performance for the overall unit in accordance with standard EN 14511

Observe daily power interruptions!
 see "Engineering heat pumps general"

Performance data – heating

Maximum heat output allowing for defrosting losses

Belaria® pro comfort (15)

Data according to EN 14511

Heat output – t_{VL} 35 °C

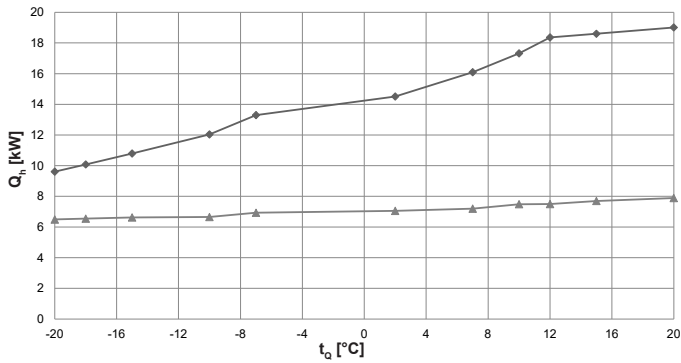

Coefficient of performance – t_{VL} 35 °C

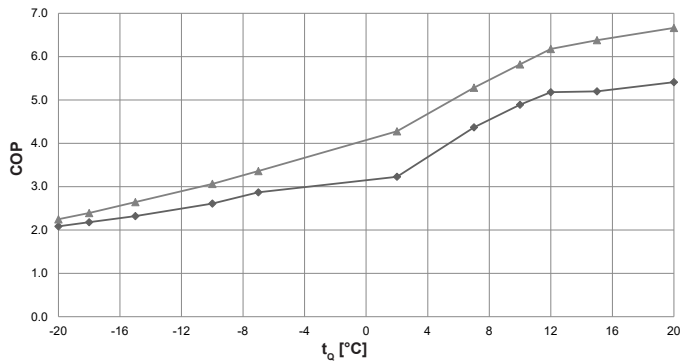

Heat output – t_{VL} 45 °C

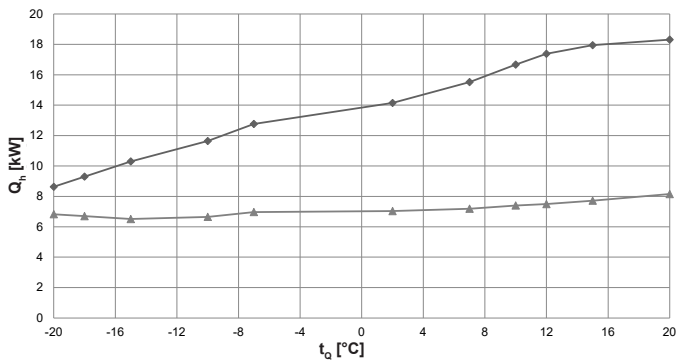

Coefficient of performance – t_{VL} 45 °C

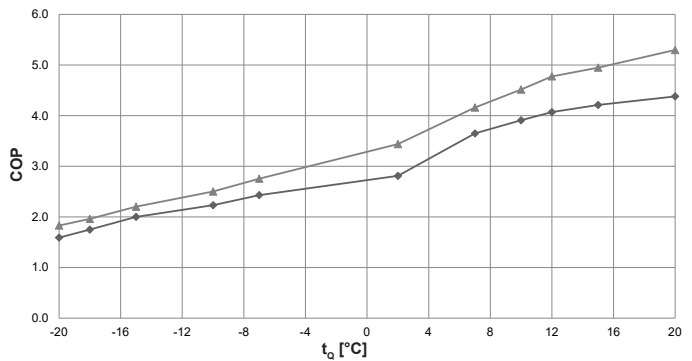

Heat output – t_{VL} 55 °C

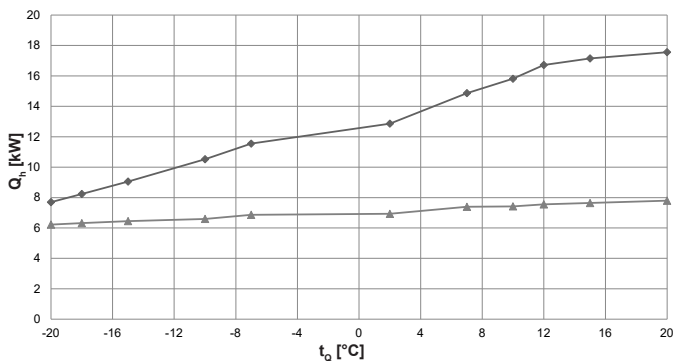

Coefficient of performance – t_{VL} 55 °C

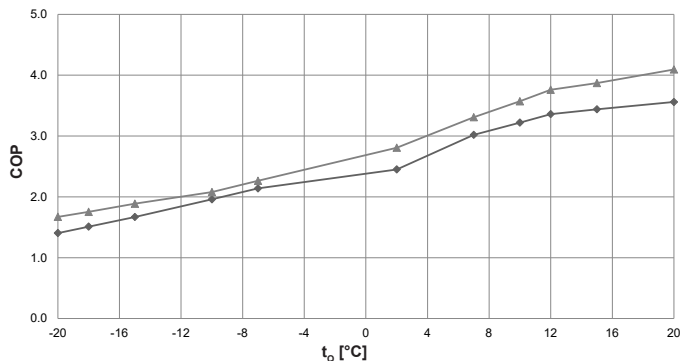

Heat output – t_{VL} 70 °C

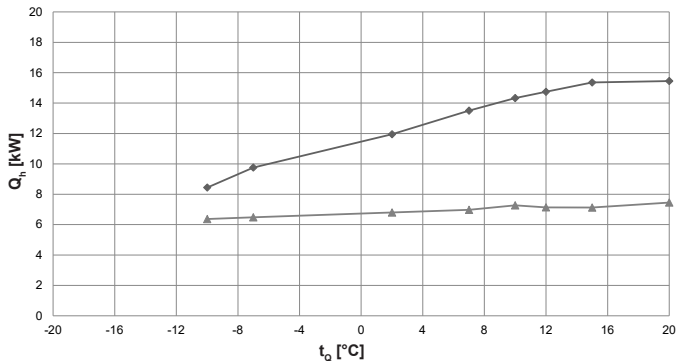

Coefficient of performance – t_{VL} 70 °C

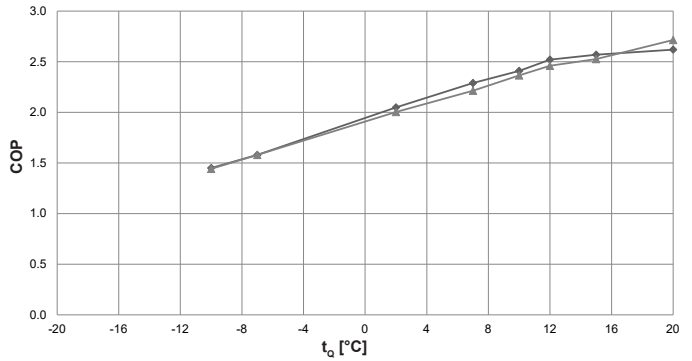

t_{VL} = heating flow temperature (°C)

t_O = source temperature (°C)

Q_h = heat output (kW), measured in accordance with standard EN 14511

COP = Coefficient of Performance for the overall unit in accordance with standard EN 14511

◆ Maximum output
 ▲ Minimum output

Performance data – heating

Belaria® pro comfort (15)

Data according to EN 14511

t_{VL} °C	t_C °C	Maximum output			Minimum output		
		Q_h kW	P kW	COP	Q_h kW	P kW	COP
35	-20	9.6	4.6	2.1	6.5	2.9	2.2
	-18	10.1	4.6	2.2	6.5	2.7	2.4
	-15	10.8	4.7	2.3	6.6	2.5	2.6
	-10	12.0	4.6	2.6	6.7	2.2	3.1
	-7	13.3	4.6	2.9	6.9	2.1	3.4
	2	14.5	4.5	3.2	7.1	1.6	4.3
	7	16.1	3.7	4.4	7.2	1.4	5.3
	10	17.3	3.5	4.9	7.5	1.3	5.8
	12	18.4	3.5	5.2	7.5	1.2	6.2
	15	18.6	3.6	5.2	7.7	1.2	6.4
	20	19.0	3.5	5.4	7.9	1.2	6.7
45	-20	8.6	5.4	1.6	6.8	3.7	1.8
	-18	9.3	5.3	1.8	6.7	3.4	2.0
	-15	10.3	5.2	2.0	6.5	3.0	2.2
	-10	11.6	5.2	2.2	6.7	2.7	2.5
	-7	12.8	5.3	2.4	7.0	2.5	2.8
	2	14.2	5.0	2.8	7.0	2.0	3.4
	7	15.5	4.3	3.7	7.2	1.7	4.2
	10	16.7	4.3	3.9	7.4	1.6	4.5
	12	17.4	4.3	4.1	7.5	1.6	4.8
	15	17.9	4.3	4.2	7.7	1.6	4.9
	20	18.3	4.2	4.4	8.2	1.5	5.3
50	-20	8.1	5.4	1.5	6.5	3.7	1.7
	-18	8.8	5.4	1.6	6.5	3.5	1.9
	-15	9.9	5.4	1.8	6.5	3.2	2.0
	-10	11.1	5.3	2.1	6.6	2.9	2.3
	-7	12.3	5.5	2.2	6.9	2.8	2.5
	2	13.5	5.1	2.6	7.0	2.2	3.1
	7	15.2	4.7	3.3	7.3	2.0	3.7
	10	16.3	4.7	3.5	7.4	1.8	4.0
	12	17.1	4.7	3.7	7.5	1.8	4.3
	15	17.5	4.7	3.8	7.7	1.8	4.4
	20	17.9	4.5	4.0	8.0	1.7	4.7
55	-20	7.7	5.5	1.4	6.2	3.7	1.7
	-18	8.2	5.5	1.5	6.3	3.6	1.8
	-15	9.1	5.4	1.7	6.5	3.4	1.9
	-10	10.5	5.4	2.0	6.6	3.2	2.1
	-7	11.6	5.4	2.1	6.9	3.0	2.3
	2	12.9	5.2	2.5	6.9	2.5	2.8
	7	14.9	4.9	3.0	7.4	2.2	3.3
	10	15.8	4.9	3.2	7.4	2.1	3.6
	12	16.7	5.0	3.4	7.6	2.0	3.8
	15	17.2	5.0	3.4	7.6	2.0	3.9
	20	17.6	4.9	3.6	7.8	1.9	4.1

t_{VL} = heating flow temperature (°C)

t_C = source temperature (°C)

Q_h = heat output (kW), measured in accordance with standard EN 14511

P = power consumption for the overall unit (kW)

COP = Coefficient of Performance for the overall unit in accordance with standard EN 14511

Further performance data – heating
see next page

Observe daily power interruptions!
see "Engineering heat pumps general"

Performance data – heating

Belaria® pro comfort (15)

Data according to EN 14511

t_{VL} °C	t_Q °C	Maximum output			Minimum output		
		Q_h kW	P kW	COP	Q_h kW	P kW	COP
60	-20	6.3	4.9	1.3	6.3	4.3	1.5
	-18	7.0	5.2	1.4	6.3	4.1	1.5
	-15	8.2	5.6	1.5	6.4	3.9	1.7
	-10	9.5	5.6	1.7	6.5	3.5	1.8
	-7	10.8	5.4	2.0	6.7	3.4	2.0
	2	12.4	5.5	2.3	6.8	2.8	2.4
	7	14.5	5.4	2.7	7.0	2.5	2.8
	10	15.5	5.4	2.8	7.3	2.4	3.0
	12	16.1	5.4	3.0	7.3	2.3	3.2
	15	16.4	5.4	3.0	7.3	2.3	3.3
70	20	16.7	5.1	3.3	7.4	2.1	3.5
	-20	-	-	-	-	-	-
	-18	-	-	-	-	-	-
	-15	-	-	-	-	-	-
	-10	8.4	5.8	1.5	6.4	4.4	1.4
	-7	9.8	6.2	1.6	6.5	4.1	1.6
	2	12.0	5.8	2.1	6.8	3.4	2.0
	7	13.5	5.9	2.3	7.0	3.2	2.2
	10	14.3	5.9	2.4	7.3	3.1	2.4
	12	14.7	5.8	2.5	7.1	2.9	2.5
15	15.4	6.0	2.6	7.1	2.8	2.5	
20	15.5	5.9	2.6	7.5	2.7	2.7	

t_{VL} = heating flow temperature (°C)

t_Q = source temperature (°C)

Q_h = heat output (kW), measured in accordance with standard EN 14511

P = power consumption for the overall unit (kW)

COP = Coefficient of Performance for the overall unit in accordance with standard EN 14511

Observe daily power interruptions!
see "Engineering heat pumps general"

Performance data – cooling

Maximum cooling capacity

Belaria® pro comfort (8), compact (8/100/300)

Data according to EN 14511

Cooling capacity – t_{VL} 18 °C

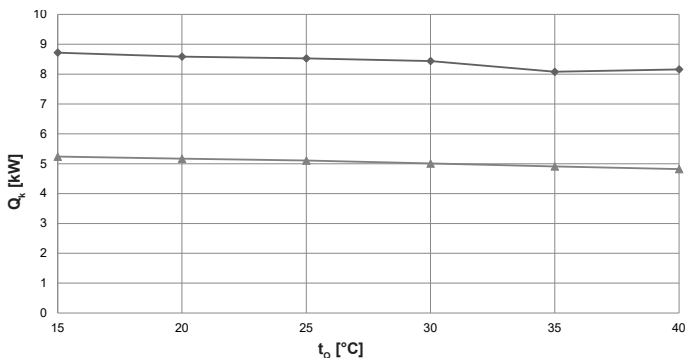

Energy efficiency ratio – t_{VL} 18 °C

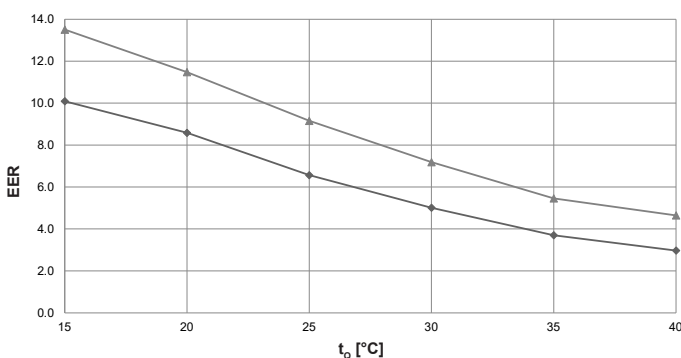

◆ Maximum output
▲ Minimum output

Belaria® pro comfort (8), compact (8/100/300)

Data according to EN 14511

t_{VL} °C	t_q °C	Maximum output			Minimum output		
		Q_k kW	P kW	EER	Q_k kW	P kW	EER
7	15	8.7	1.0	8.6	5.1	0.5	10.3
	20	8.2	2.0	4.2	4.9	0.8	6.3
	25	7.8	2.3	3.4	4.7	0.9	5.1
	30	7.1	2.4	2.9	4.4	1.0	4.3
	35	6.4	3.0	2.2	4.1	1.3	3.3
	40	5.7	2.7	2.1	3.9	1.3	3.0
12	15	8.7	0.7	12.2	5.2	0.4	13.9
	20	8.6	1.5	5.6	5.1	0.6	8.1
	25	8.6	2.1	4.0	5.1	0.8	6.2
	30	8.1	2.4	3.4	4.8	0.9	5.3
	35	7.4	2.9	2.6	4.5	1.1	4.3
	40	6.9	2.8	2.5	4.2	1.1	4.0
18	15	8.7	0.9	10.1	5.2	0.4	13.5
	20	8.6	1.0	8.6	5.2	0.5	11.5
	25	8.5	1.3	6.6	5.1	0.6	9.2
	30	8.4	1.7	5.0	5.0	0.7	7.2
	35	8.1	2.2	3.7	4.9	0.9	5.5
	40	8.2	2.8	3.0	4.8	1.0	4.7

t_{VL} = cooling water flow temperature (°C)
 t_q = source temperature (°C)
 Q_k = cooling capacity (kW), measured in accordance with standard EN 14511
P = power consumption for the overall unit (kW)
EER = Energy Efficiency Ratio for the overall unit in accordance with standard EN 14511

Observe daily power interruptions!
see "Engineering heat pumps general"

Performance data – cooling

Maximum cooling capacity

Belaria® pro comfort (13), compact (13/100/300)

Data according to EN 14511

Cooling capacity – t_{VL} 18 °C

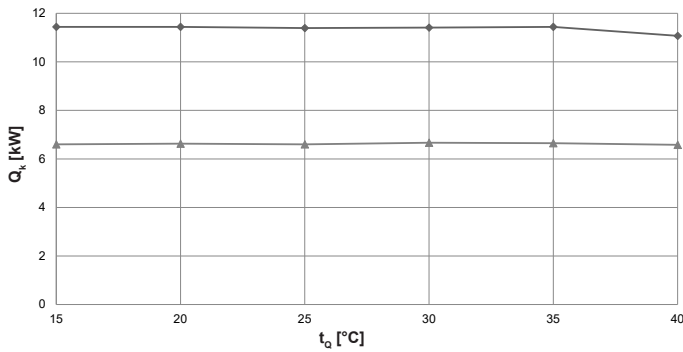

Energy efficiency ratio – t_{VL} 18 °C

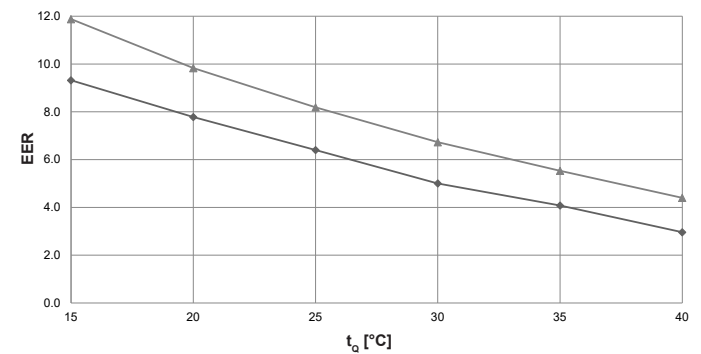

◆ Maximum output
 ▲ Minimum output

Belaria® pro comfort (13), compact (13/100/300)

Data according to EN 14511

t_{VL} °C	t_o °C	Maximum output			Minimum output		
		Q_k kW	P kW	EER	Q_k kW	P kW	EER
7	15	11.4	2.6	4.5	6.6	0.9	7.1
	20	11.0	2.9	3.8	6.5	1.1	5.8
	25	10.4	3.1	3.3	6.3	1.3	4.8
	30	9.6	3.3	2.9	6.1	1.5	4.0
	35	8.8	3.6	2.5	5.9	1.8	3.3
	40	7.8	3.7	2.1	5.6	2.1	2.7
12	15	11.4	1.8	6.4	6.6	0.8	8.8
	20	11.4	2.3	5.1	6.6	0.9	7.2
	25	11.4	2.9	3.9	6.6	1.1	5.9
	30	10.9	3.2	3.4	6.5	1.3	5.1
	35	10.3	3.5	2.9	6.3	1.5	4.2
	40	9.4	3.7	2.5	6.1	1.7	3.5
18	15	11.4	1.2	9.3	6.6	0.6	11.9
	20	11.4	1.5	7.8	6.6	0.7	9.8
	25	11.4	1.8	6.4	6.6	0.8	8.2
	30	11.4	2.3	5.0	6.7	1.0	6.7
	35	11.4	2.8	4.1	6.7	1.2	5.5
	40	11.1	3.7	3.0	6.6	1.5	4.4

t_{VL} = cooling water flow temperature (°C)
 t_o = source temperature (°C)
 Q_k = cooling capacity (kW), measured in accordance with standard EN 14511
 P = power consumption for the overall unit (kW)
 EER = Energy Efficiency Ratio for the overall unit in accordance with standard EN 14511

Observe daily power interruptions!
 see "Engineering heat pumps general"

Performance data – cooling

Maximum cooling capacity

Belaria® pro comfort (15)

Data according to EN 14511

Cooling capacity – $t_{VL} 18\text{ °C}$

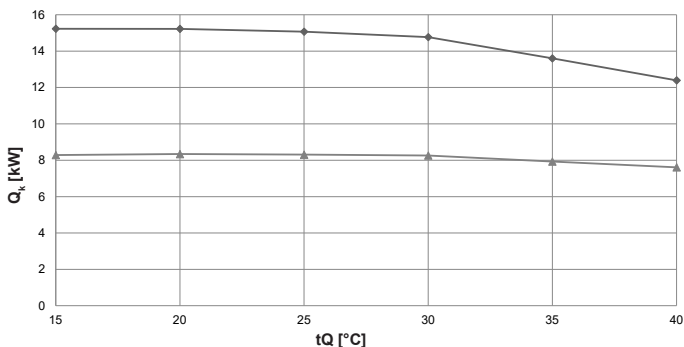

Energy efficiency ratio – $t_{VL} 18\text{ °C}$

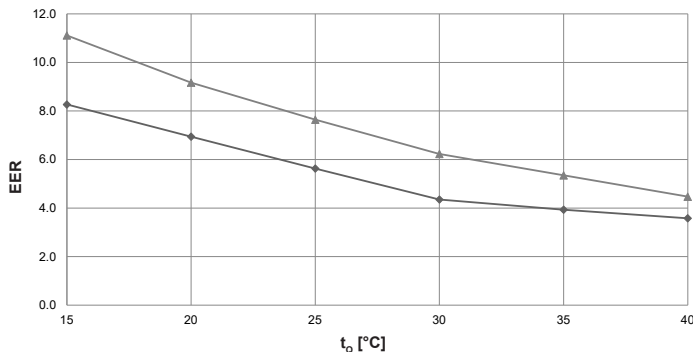

◆ Maximum output
 ▲ Minimum output

Belaria® pro comfort (15)

Data according to EN 14511

t_{VL} °C	t_Q °C	Maximum output			Minimum output		
		Q_k kW	P kW	EER	Q_k kW	P kW	EER
7	15	14.1	3.0	4.7	8.0	1.2	6.6
	20	13.1	3.3	4.0	7.8	1.4	5.7
	25	11.9	3.3	3.6	7.4	1.5	5.0
	30	10.7	3.4	3.2	7.0	1.7	4.1
	35	10.0	3.4	2.9	6.9	2.0	3.5
	40	9.0	3.4	2.6	6.6	2.3	2.9
12	15	15.1	2.6	5.7	8.3	1.0	8.2
	20	14.6	3.2	4.5	8.2	1.2	6.9
	25	13.9	3.3	4.2	8.0	1.3	6.1
	30	12.6	3.3	3.8	7.6	1.5	5.1
	35	11.6	3.4	3.5	7.3	1.7	4.4
	40	10.7	3.4	3.1	7.1	2.0	3.6
18	15	15.2	1.8	8.3	8.3	0.7	11.1
	20	15.2	2.2	6.9	8.3	0.9	9.2
	25	15.1	2.7	5.6	8.3	1.1	7.6
	30	14.8	3.4	4.4	8.3	1.3	6.2
	35	13.6	3.5	3.9	7.9	1.5	5.4
	40	12.4	3.5	3.6	7.6	1.7	4.5

t_{VL} = cooling water flow temperature (°C)
 t_Q = source temperature (°C)
 Q_k = cooling capacity (kW), measured in accordance with standard EN 14511
 P = power consumption for the overall unit (kW)
 EER = Energy Efficiency Ratio for the overall unit in accordance with standard EN 14511

Observe daily power interruptions!
 see "Engineering heat pumps general"

Belaria® pro
Outdoor unit
 (Dimensions in mm)

Front view

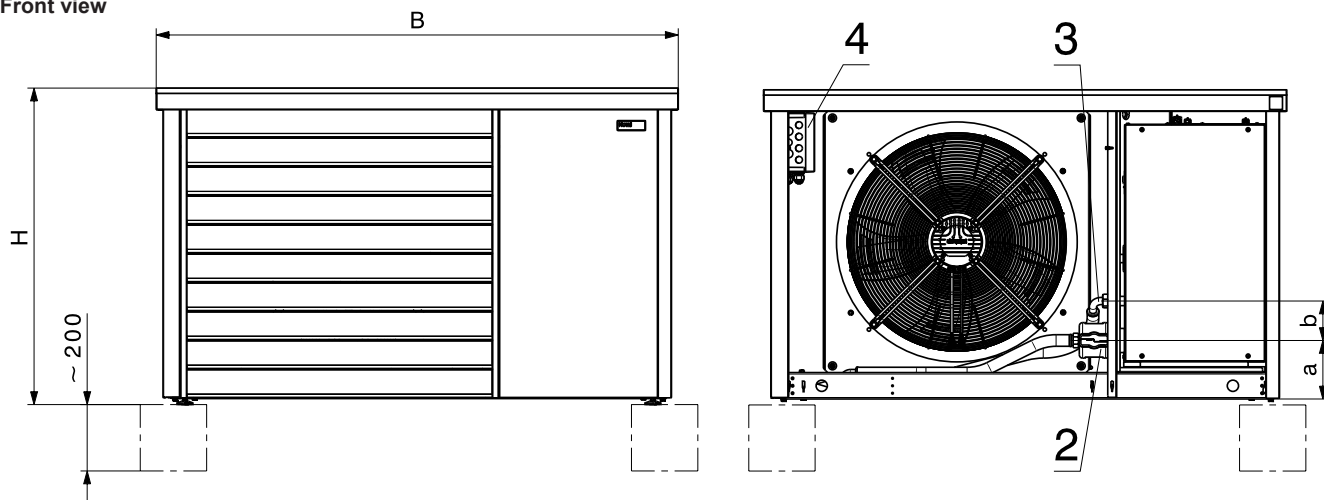

View from the left

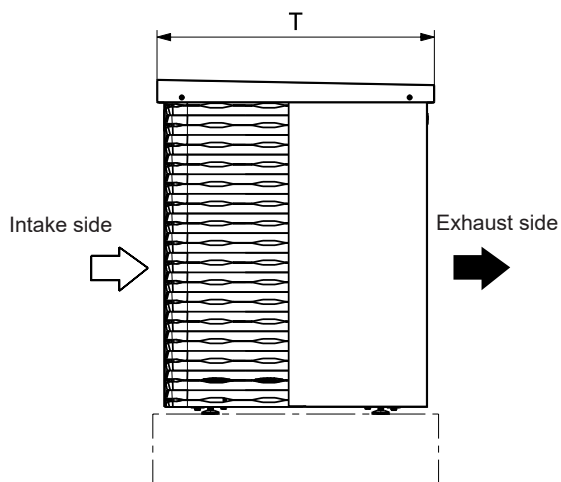

View from top

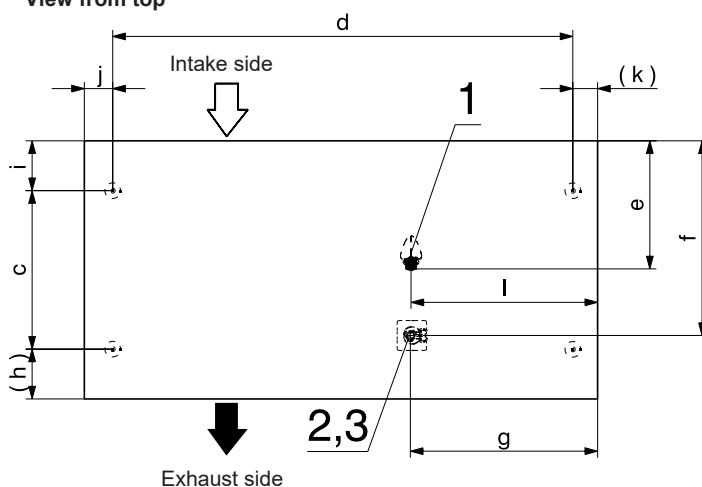

- 1 Condensate drain 1"
- 2 Connection hydraulic connection line return (8,13): 1" ET/(15): 1¼" ET
- 3 Connection hydraulic connection line flow (8,13): 1" ET/(15): 1¼" ET
- 4 Electrical connection

Type	H	B	T	a	b	c	d	e	f	g	h	i	j	k	l
Belaria® pro (8)	954	1575	791	177	120	485	1410	400	600	620	150	155	90	75	570
Belaria® pro (13)	954	1575	791	177	120	485	1410	400	600	620	150	155	90	75	570
Belaria® pro (15)	1432	1575	791	177	120	485	1410	400	600	645	150	155	90	75	570

Belaria® pro
Outdoor unit
 (Dimensions in mm)

Centre of gravity

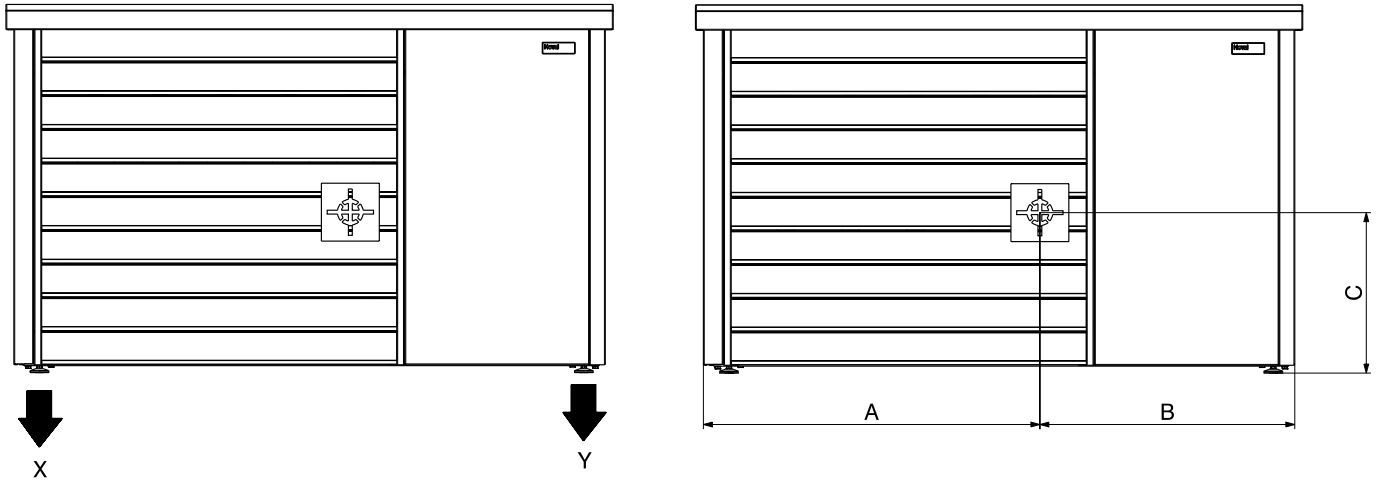

Type	Position (mm)			Weight (kg)	
	A	B	C	X	Y
Belaria® pro (8)	972	562	483	100	187
Belaria® pro (13)	967	568	482	105	195
Belaria® pro (15)	918	619	630	122	228

Belaria® pro comfort (8-15)

Indoor unit

(Dimensions in mm)

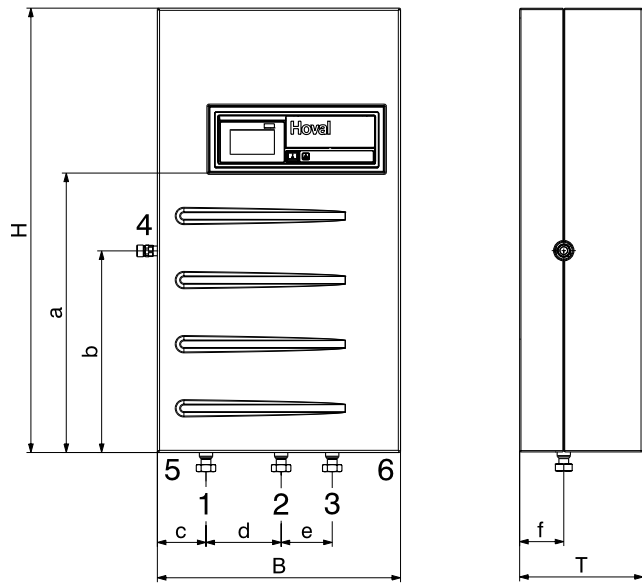

- 1 Flow outdoor unit (return not guided through indoor unit) 1" ET Belaria® pro (8,13)
1¼" ET Belaria® pro (15)
- 2 Flow heating 1" ET Belaria® pro (8,13)
1¼" ET Belaria® pro (15)
- 3 Flow hot water charging 1" ET Belaria® pro (8,13)
1¼" ET Belaria® pro (15)
- 4 Connection for diaphragm pressure expansion tank/pressure gauge ¾" ET
- 4 Safety assembly (accessories)
- 5 Cable feed-in sensors, RS485
- 6 Cable feed-in main current, control current

Type	H	B	T	a	b	c	d	e	f
Belaria® pro comfort (8)	1005	550	280	630	455	110	170	115	100
Belaria® pro comfort (13)	1005	550	280	630	455	110	170	115	100
Belaria® pro comfort (15)	1005	550	280	630	455	110	170	115	100

Belaria® pro comfort (8-15)

Indoor unit wall-mounted

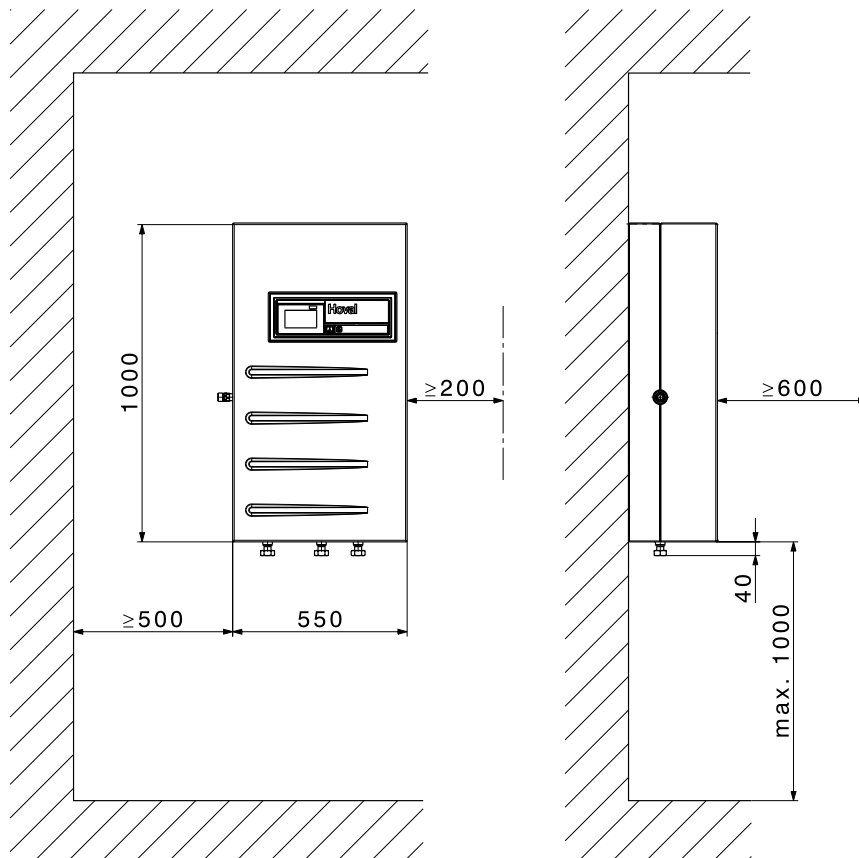

To ensure good operability and accessibility to the electrical/hydraulic connections, a clearance of max. 1000 mm must be provided from the ground to the lower edge of the indoor unit.

Belaria® pro compact (8/100/300), (13/100/300)
Indoor unit with buffer storage tank and calorifier
(Dimensions in mm)

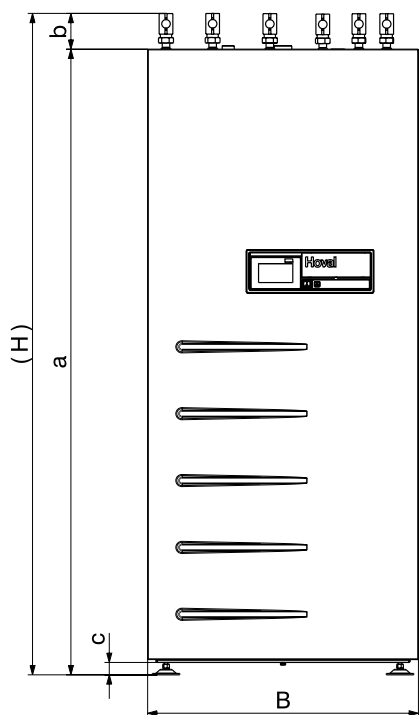

View from above

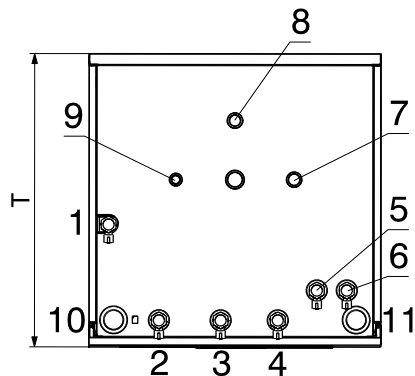

- 1 Outdoor unit flow 1" IT
- 2 Outdoor unit return 1" IT
- 3 Flow second heating circuit (optional) 1" IT
- 4 Return second heating circuit (optional) 1" IT
- 5 Flow heating circuit 1" IT
- 6 Return heating circuit 1" IT
- 7 Hot water connection 1" IT
- 8 Cold water connection 1" IT
- 9 Circulation connection 3/4" ET
- 10 Cable feed-in sensors, RS485
- 11 Cable feed-in main current, control current

Type	H	B	T	a	b	c
Belaria® pro compact (8/100/300)	1930	790	790	1825	105	38
Belaria® pro compact (13/100/300)	1930	790	790	1825	105	38

Belaria® pro compact (8/100/300), (13/100/300)
Indoor unit floor-mounted

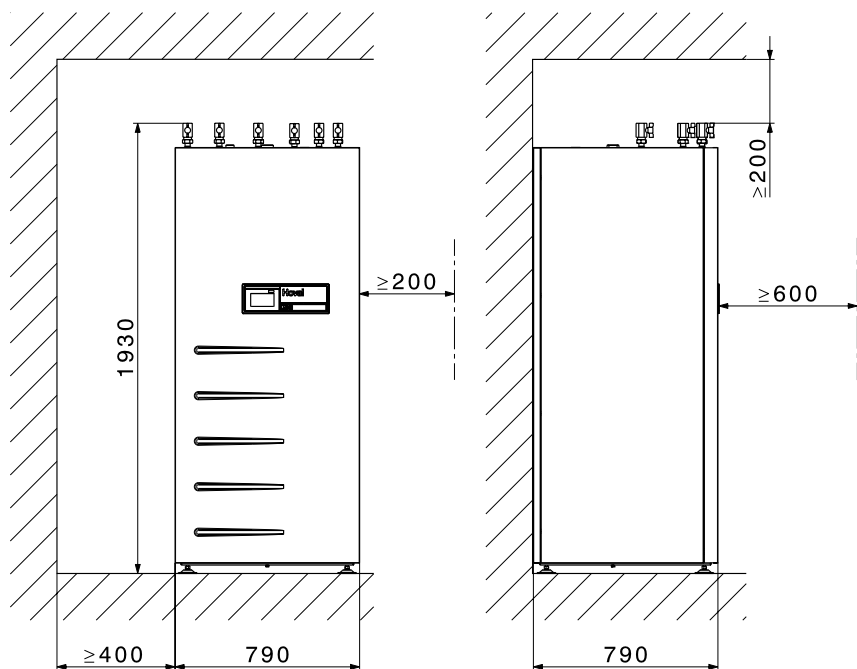

To ensure accessibility to the electrical/hydraulic connections, a clearance of at least 200 mm must be provided above the indoor unit. In addition, the side clearances must be observed.

Space requirement
 (Dimensions in mm)

Belaria® pro
Outdoor unit

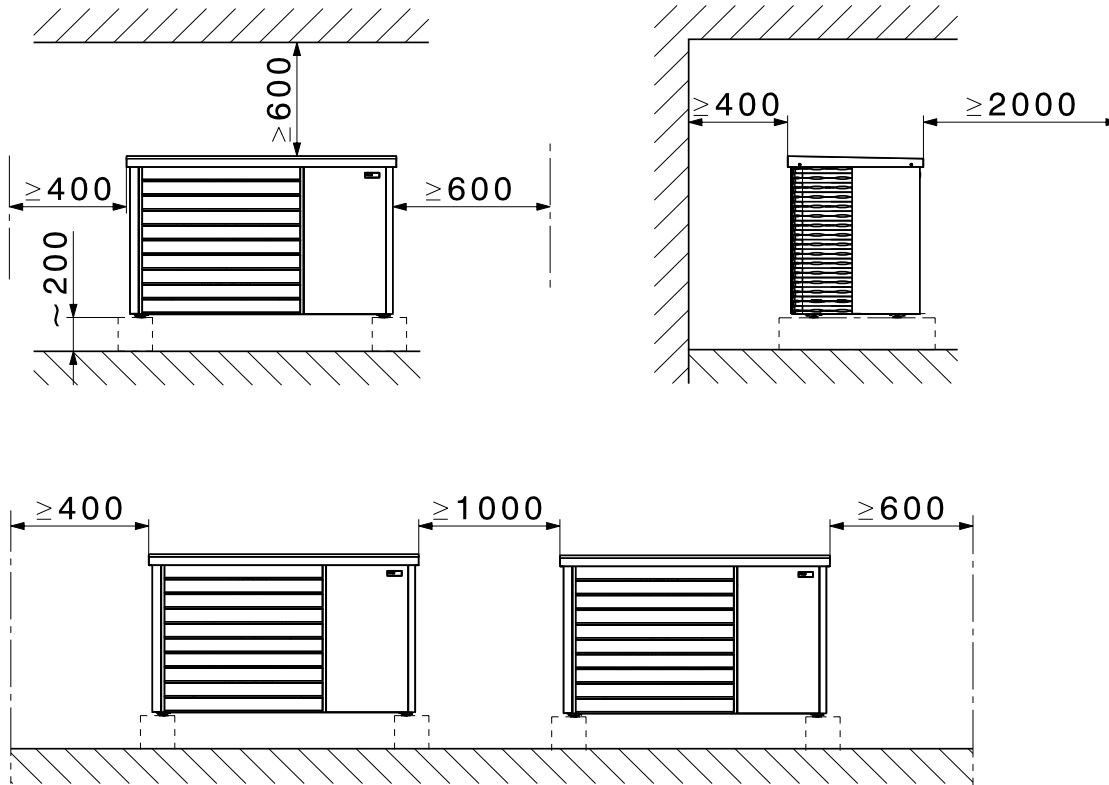

Any possible openings/recesses and ignition sources must be avoided within a radius of one meter around the outdoor unit.

In order to ensure accessibility during maintenance, a clearance of at least 600 mm upwards must be maintained. For any service work, the minimum clearances at the rear and sides of the heat pump must be observed.

Belaria® pro
Outdoor unit

View from above

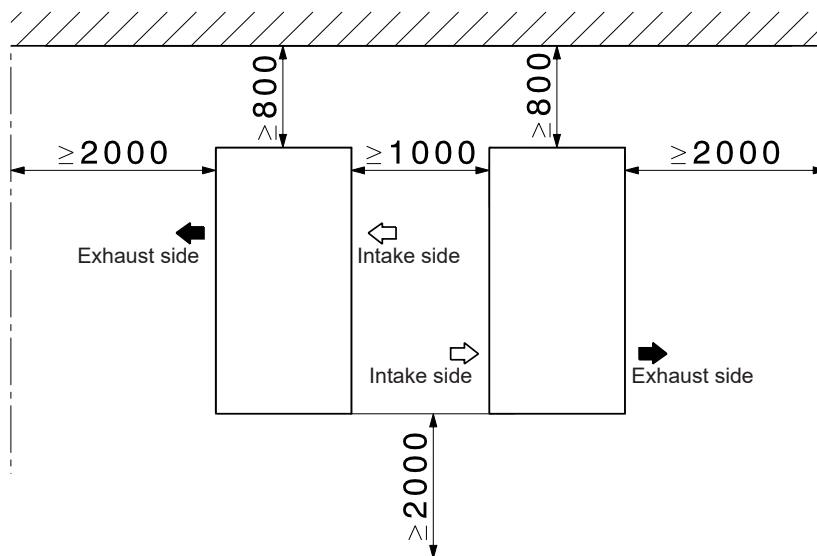

Presentation of protection areas

Belaria® pro with refrigerant R290
 (Dimensions in mm)

Floor plan – protection area when installed in front of a wall

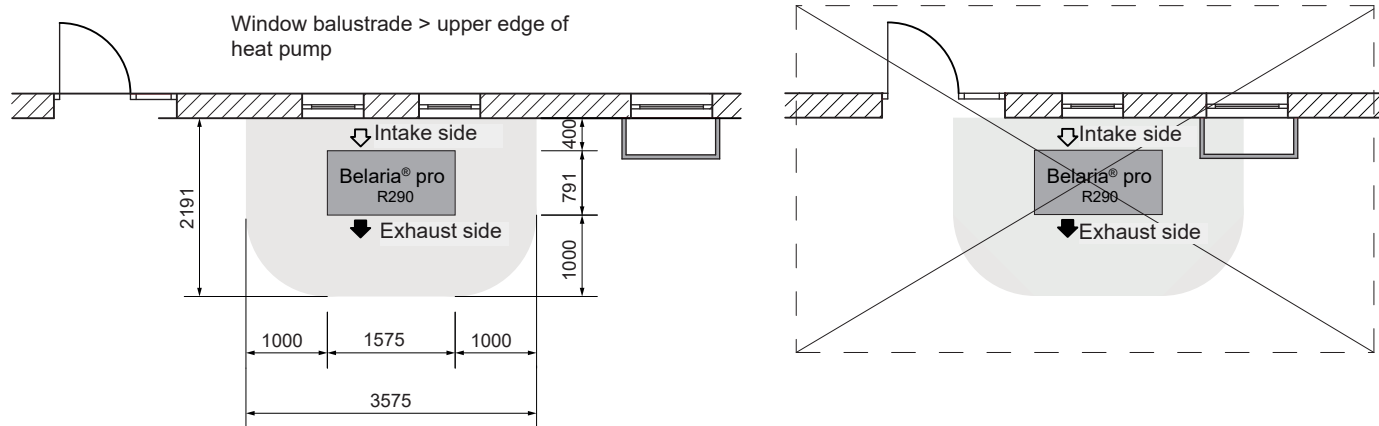

View – protection area when installed in front of a wall

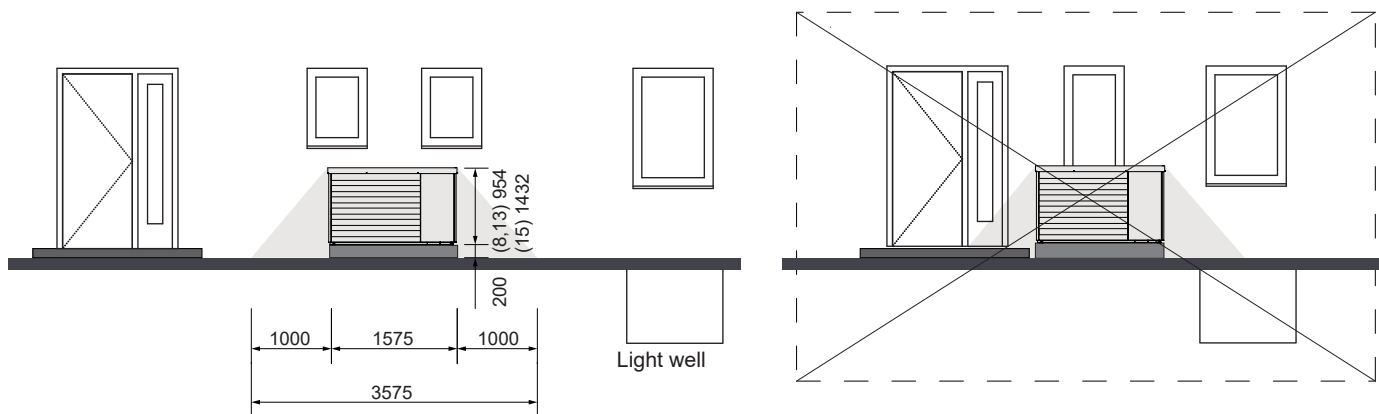

- The heat pump (outdoor unit) is only allowed to be placed outdoors and under no circumstances indoors.
- The outdoor unit is filled with the non-toxic, odourless and colourless but flammable refrigerant R290 (propane), which is heavier than air. If this escapes, there is a danger of fire/explosion. Therefore, all potential sources of ignition must be kept at least 1 m away in all directions. Smoking and the use of naked flames is prohibited in this area.
- Window balustrades must be higher than the upper edge of the outdoor unit in the protection area!
- The heat pump must be at least 1 m from the property boundary; observe building regulations!
- At the entrances to properties, it must be ensured that no vehicle can enter the protection area.
- To prevent the heat pump from being touched by vehicles, a collision guard must be installed if necessary. This must be located outside the protected area.

Floor plan – protection area when installed outdoors

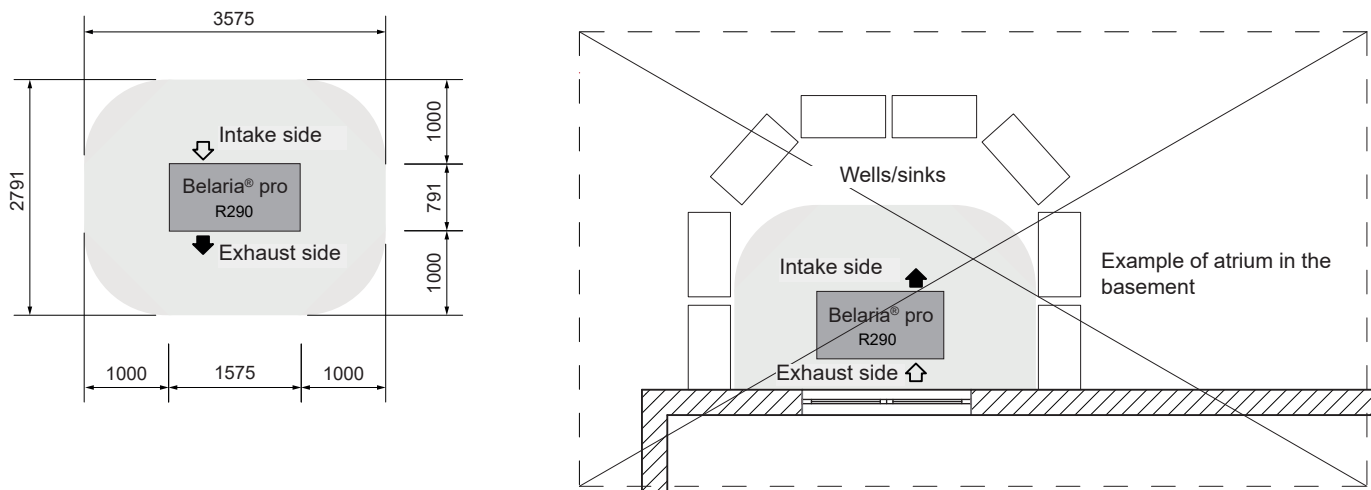

Floor plan flat roof – protection area

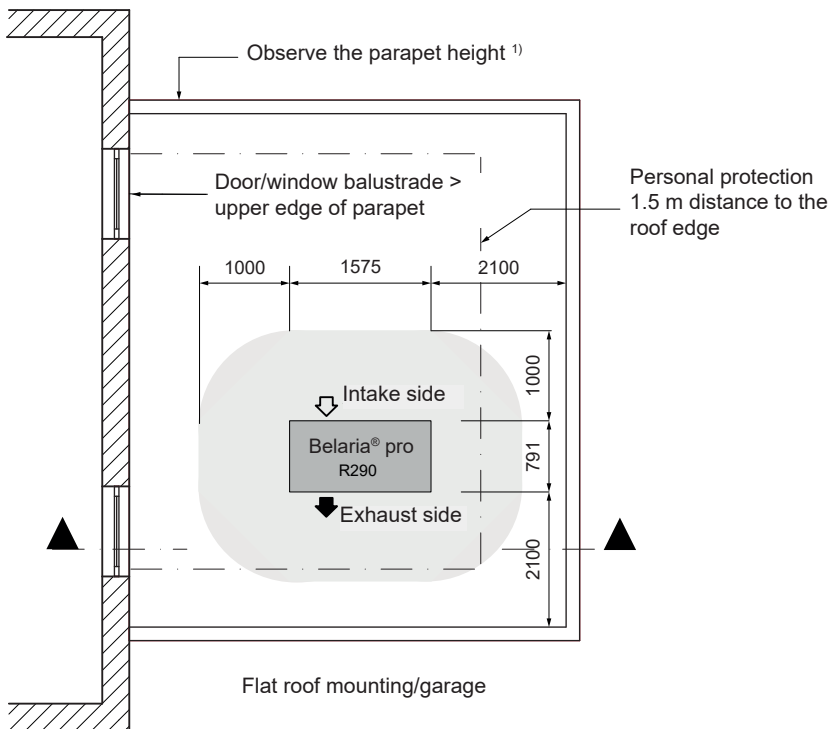

1) In case of flat roof installation, the parapet must not represent a potential sink in which refrigerant could accumulate.

Section flat roof – protection area

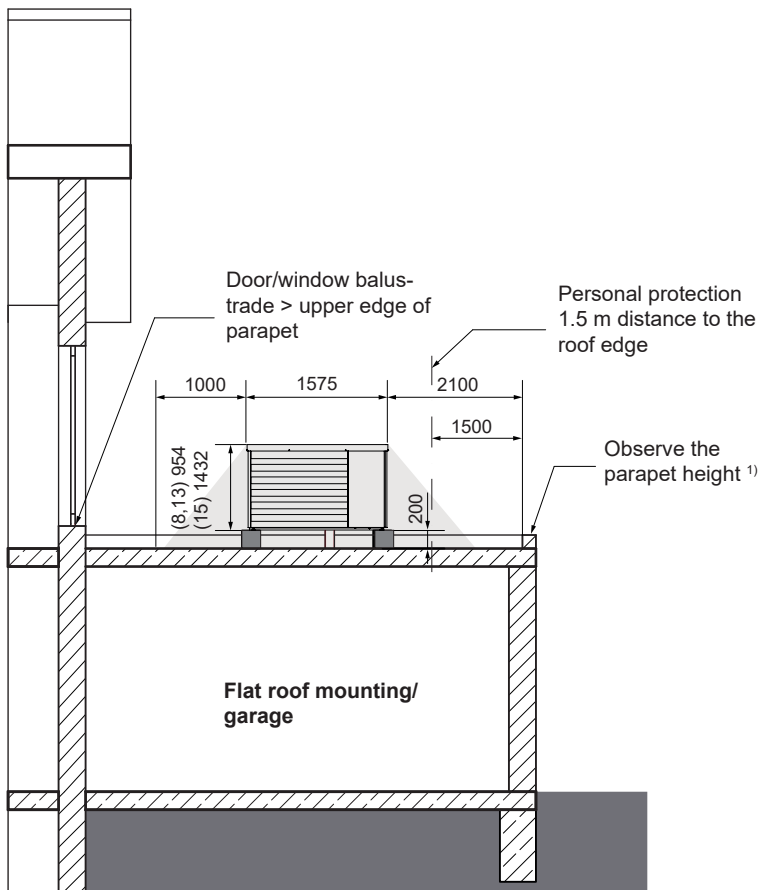

- Strict compliance with safety measures regarding combustible refrigerants.
- All standards concerning statics, wind load and access to roofs must be complied with. The outdoor unit must be firmly bolted onto the substructure (e.g. concrete base). The heat pump must be prevented from tilting.
- Minimum distance of the heat pump to the roof edge: 1.5 m (personal protection) + 0.6 m (working area refrigeration circuit).
- Accessibility for maintenance and repair work must be ensured. For work on the heat pump, a measuring case and test equipment, refrigerant bottle, etc. must be transported to the site, amongst other things. In addition to the safety equipment (fall protection devices, anchoring devices, etc.), this must also be taken into account for skylights, stairs, railings, etc.
- There must be no floor-to-ceiling doors/windows to the flat roof, or balustrade must be higher than the parapet.
- Protection areas around windows must be complied with.
- There must not be any pipe vents, skylights or the like on the flat roof within a radius of 1 m from the heat pump.
- If there is a risk of frost, a siphon must be installed in the shaft immediately before the condensate drain is introduced into the downpipe.
- Condensate drain into the sewage system via a frost-proof siphon or allow it to seep away freely.

Installation variants for Belaria® pro outdoor unit
 (Dimensions in mm)

Firm base on site with strip foundation

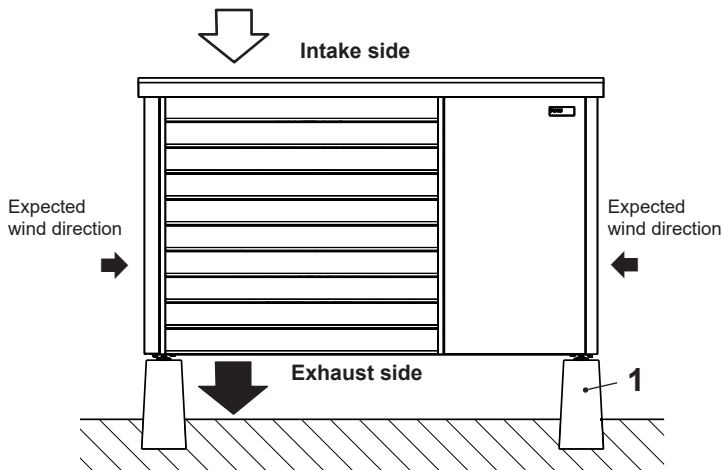

1 Concrete base on site

The base must not form a sink. A circumferential base is therefore not permitted.

Installation variants for Belaria® pro outdoor unit
 (Dimensions in mm)

Strip foundation

Plan concrete base set
 (view from above)

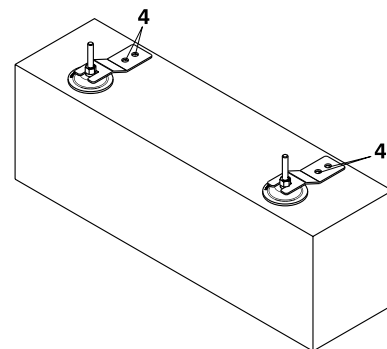
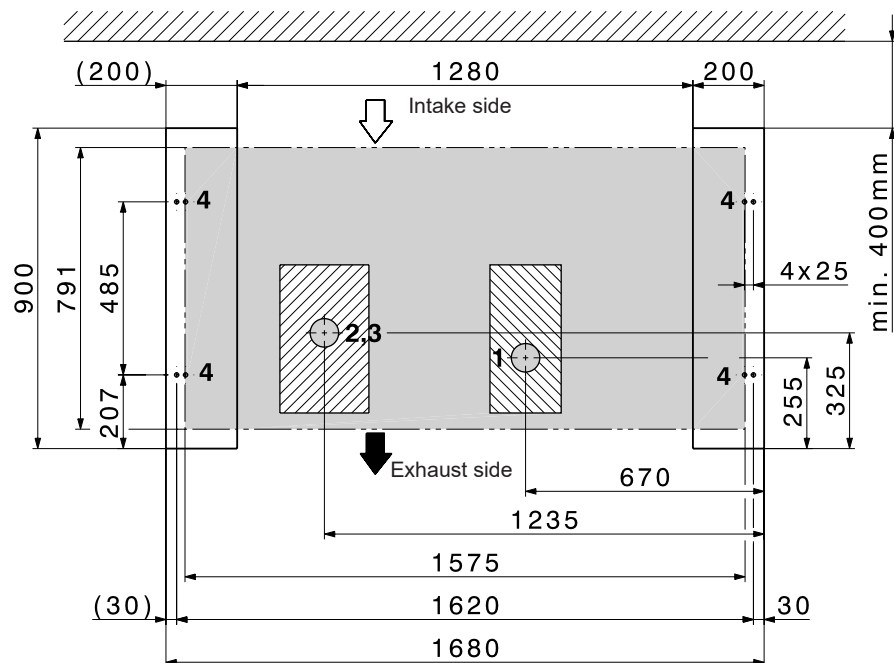

Attachment of the outdoor unit from the outside (laterally) using the supplied clamps. The clamps are visible. It is not necessary to remove the cladding sections.

- Possible area for empty tubes in the strip foundation
- Possible area for condensate drain in the strip foundation

- 1 Condensate drain area
- 2 Area Flow hydraulics
Return hydraulics
- 3 Electrics area
- 4 Attachment points M8 Belaria® pro (dowels in scope of delivery)

Installation variants for Belaria® pro outdoor unit
 (Dimensions in mm)

Firm base on site with floor plate

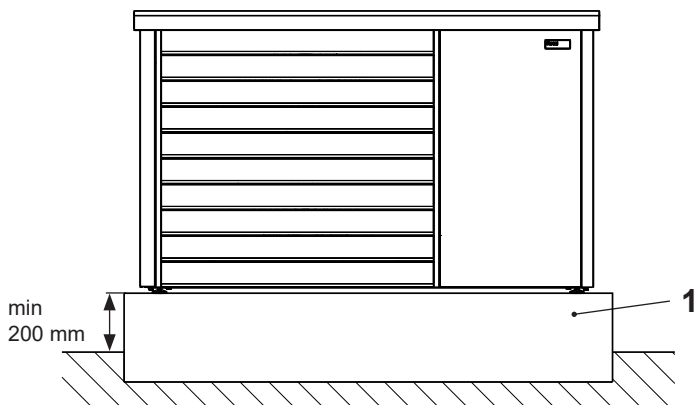

1 Floor plate on site

The base must not form a sink. A circumferential base is therefore not permitted.

Floor plate

Plan
 (view from above)

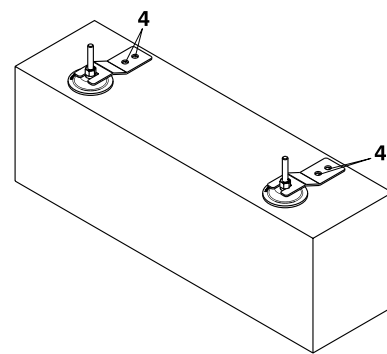
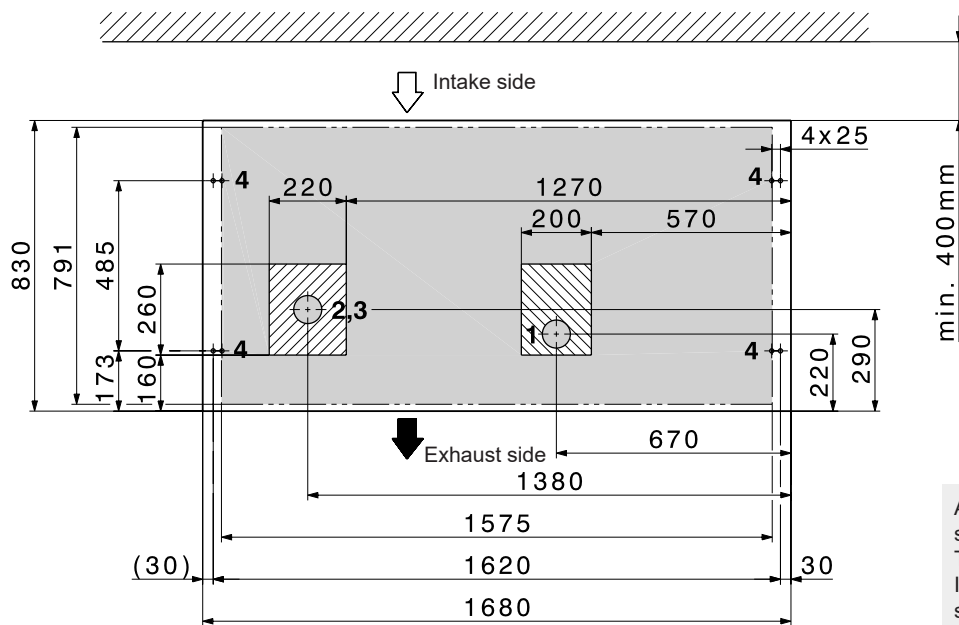

Attachment of the outdoor unit from the outside (laterally) using the supplied clamps. The clamps are visible. It is not necessary to remove the cladding sections.

- Possible area for empty tubes in the floor plate
- Possible area for condensate drain in the floor plate

- 1 Condensate drain area
- 2 Area Flow hydraulics
Return hydraulics
- 3 Electrics area
- 4 Attachment points M8 Belaria® pro (dowels in scope of delivery)

Installation variants for Belaria® pro outdoor unit
 (Dimensions in mm)

Floor plate
 Plan
 (view from above)

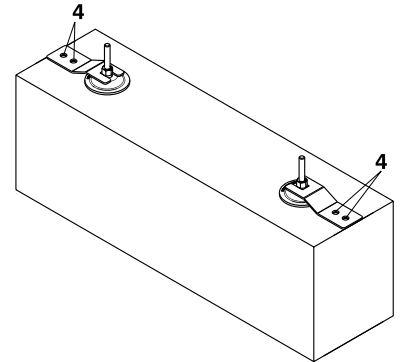
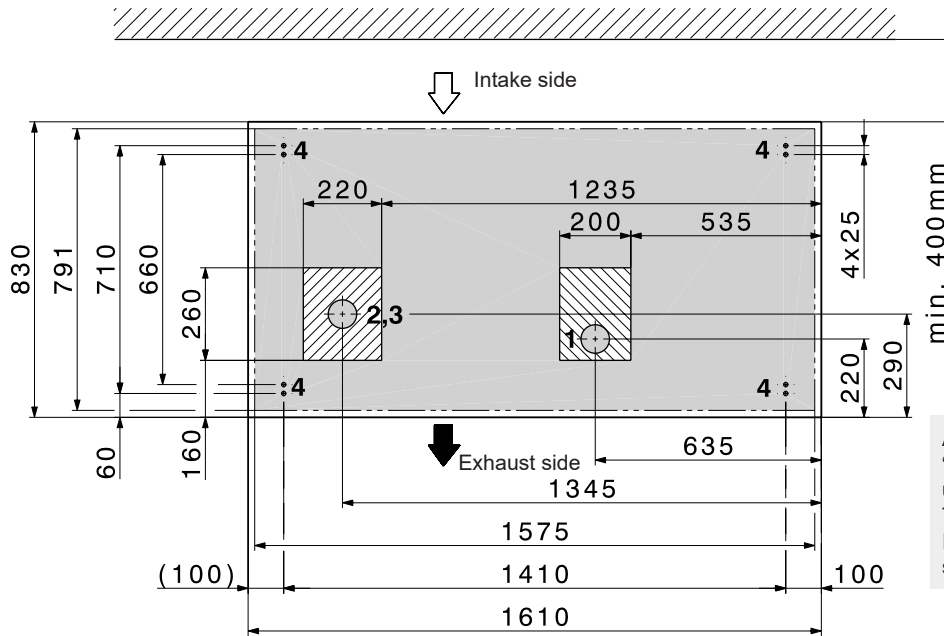

Attachment of the outdoor unit from the "inside/bottom" (grey area) of the heat pump using the supplied clamps. The clamps are not visible. It is necessary to remove the cladding sections.

- Possible area for empty tubes in the floor plate
- Possible area for condensate drain in the floor plate

- 1 Condensate drain area
- 2 Area Flow hydraulics
Return hydraulics
- 3 Electrics area
- 4 Attachment points M8 Belaria® pro (dowels in scope of delivery)

Configuration and connection diagram Belaria® pro

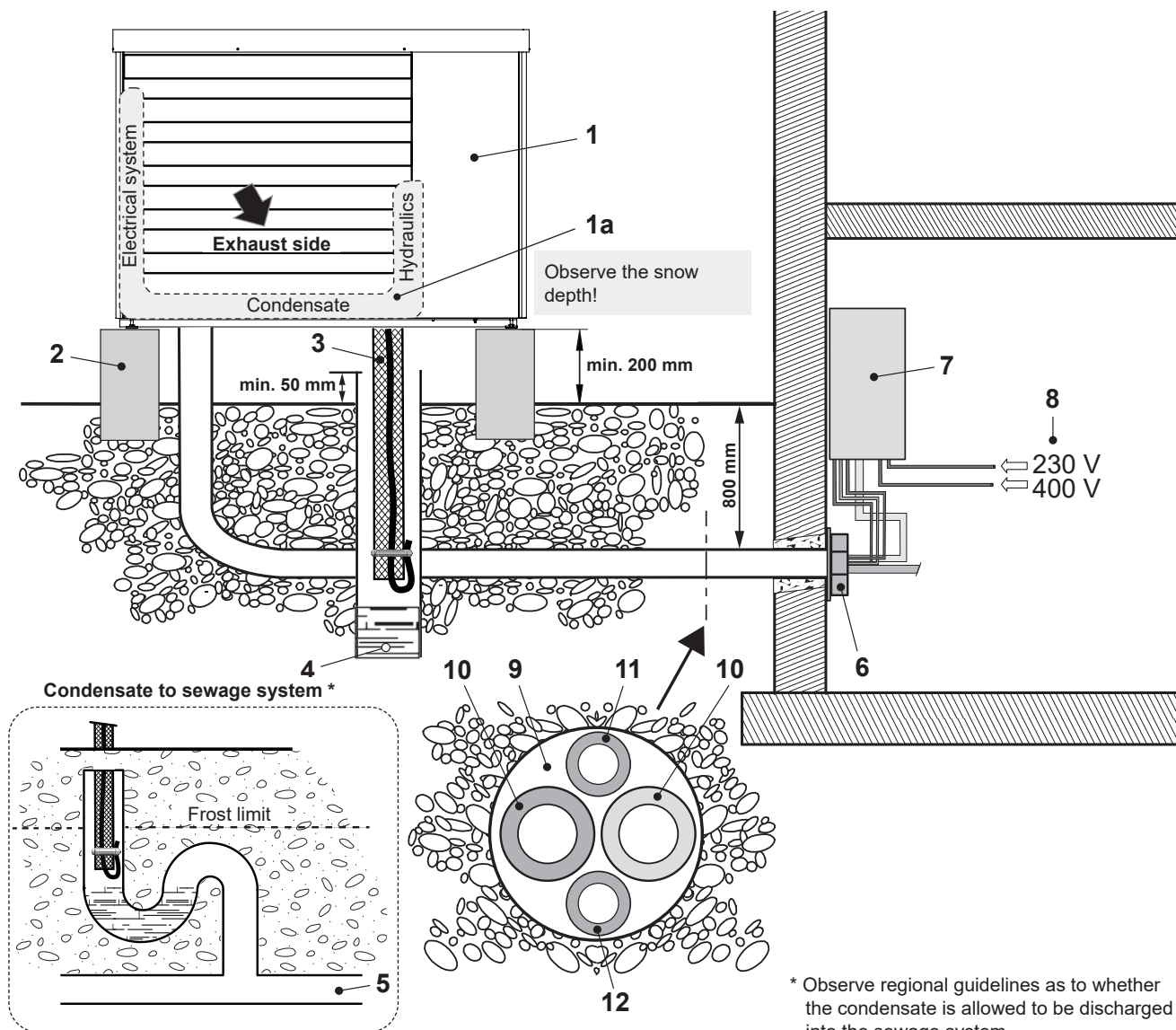

- | | |
|--|---|
| <p>1 Outdoor unit
 1a Space for connection of hydraulics (FL + RT), condensate drain and electrics.
 2 Concrete base
 3 Condensate drain heat pump Ø 28 mm, drain pipe DN 100
 4 Variant 1: Seepage (duct/gravel layer)
 5 Variant 2: Discharging into the sewage system (penetration into the soil must be made leak-tight)
 6 Wall lead-through (hydraulic and electrical connections)
 7 Belaria® pro comfort indoor unit (8-15)
 On the Belaria® pro compact (8/100/300), (13/100/300), the hydraulic and electrical connections are located on the top of the unit!</p> | <p>8 Main current:
 3 x 400 V/50 Hz
 Control current:
 1 x 230 V/50 Hz
 Electric heating element main current:
 3 x 400 V/50 Hz
 Network cables (optional)
 9 Empty tube for hydraulics and electrics
 10 Connection line flow + return
 11 Empty tube for electrical connections for outdoor unit
 Main current outdoor unit: 3 x 400 V/50 Hz
 Control current outdoor unit: 1 x 230 V/50 Hz
 12 Empty tube for data bus RS485</p> |
|--|---|

Requirements and directives

The general requirements and directives listed in the chapter Engineering apply.

Set-up

- The distance between the outdoor and indoor unit must be as short as possible. Only short and simple routing of lines guarantees cost effectiveness and low heat losses.
- The maximum permitted single cable length is 30 m between the outdoor unit, via the indoor unit and the buffer storage tank. This must not be exceeded.
In general, the customer must assess whether the next larger pipe dimension is more suitable due to the pressure drop.
- There must be no building openings (windows, doors, shafts, ventilation openings, etc.) within a radius of 1 m from the outdoor unit and no potential ignition sources must be present.
- Wall ducts into the building must be airtight.
- The outdoor unit must not be placed in or near floor recesses.
- The outdoor unit must not be placed closer than 1 m to the boundary of the property. Country-specific regulations must be observed.
- The air intake and air exhaust sides must not be narrowed or blocked. The air exhaust side must be unobstructed (> 2 m).
- For efficiency reasons, the line length with the Belaria® pro comfort between the calorifier and the indoor unit is not allowed to be more than 10 m.
- When using glycol (antifreeze) – primary and/or secondary – a separating system must be used.
- Filling the entire system with glycol or a frost protection agent/water mixture is considered improper use and is not permitted. If this is nevertheless desired for frost protection reasons, the system must be designed with a system separation. Only environmental compatible frost protection agent is allowed to be used.

Outdoor unit

Important safety instruction

The heat pump (outdoor unit) is only allowed to be placed outdoors and under no circumstances indoors.

The outdoor unit is filled with the non-toxic, odourless and colourless but flammable refrigerant R290 (propane), which is heavier than air. If this occurs, there is a danger of fire/explosion. Therefore, all potential sources of ignition must be kept at least 1 m away in all directions. Smoking and the use of naked flames is prohibited in this area.

The outdoor unit is installed outdoors. The installation location must be selected carefully. It is essential that the following ancillary conditions are met:

- The maximum line length according to the installation must not be exceeded.
- The connection lines must be laid insulated and frost-proof.

- The installation location must be chosen in such a way that no noise pollution can occur (do not install near bedrooms, keep a distance from neighbours), hedges and bushes can have a sound-absorbing effect.
- Unobstructed air inflow and outflow must be possible.
- It is imperative that the minimum distances are observed (see Dimensions/Space requirement)
- The intake air must be free of impurities such as sand and aggressive substances such as ammonia, sulphur, chlorine etc.
- The outdoor unit must be installed on a load-bearing fixed structure.
- If the unit is installed at wind-prone locations, the alignment of the heat pump must be selected in such a way that the expected wind direction is crossways to the intake direction of the outdoor unit.
- If an alternative installation in areas subject to strong winds cannot be avoided, an additional wind shield in the form of a hedge, for example, should be installed, or additional fastening should be provided for the outdoor unit.
- At exposed installation locations prone to wind load, e.g. on building roofs, the surface load on the upper horizontal cover surface of the heat pump caused by wind suction must not exceed a value of 1800 N/m². The heat pump casing might be damaged if this value is not complied with.
- The permitted surface load must be determined in accordance with the specifications of standard EN 1991-1-1. Compliance must be checked by a qualified specialist. A professional inspection of the actual conditions on site is mandatory and must be carried out by a qualified specialist.
- When planning and installing the heat pump in locations exposed to wind load, please contact your sales consultant in good time.
- Notice on installing the cover: If the cover of the heat pump has been removed, it must be properly reinstalled after the work has been completed. Make sure that the cover is fully connected to the heat pump using all the screw holes provided, to ensure stability and tightness.
- If the installation location is not protected against snowfall, it must be chosen in such a way that the evaporator remains free of snow.
- The outdoor unit must always be installed on a solid surface in a horizontal position. This can be achieved by means of concrete bases or a floor plate.
- The load-bearing capability must be adequate. The unit must be fixed with 4 M8 screws.
- Air heat pumps generate condensate during operation. This can amount to 8 litres per defrost cycle within 2 minutes for the outdoor unit of the Belaria® pro.
- The condensate drain must be frost-proof so that the condensate can flow away without problems even at outdoor temperatures below 0 °C.
- If the discharge is into the sewage system, a siphon must be provided and the duct lead-through into the ground must be sealed so that no refrigerant can enter the sewage system uncontrolled.
- If there is a risk of frost, a siphon must be installed in the shaft immediately before the condensate drain is introduced into the downpipe.
- The condensate drip tray included in the outdoor unit is already equipped with tray heating at the factory that thus prevents freezing.
- The condensate drain line is also secured with the preassembled heating tape.
- The air exhaust has increased susceptibility to frost. Gutters, water pipes and water containers must not be situated right next to the exhaust.
- If installed near the coast, the location must be at least 5 km from the coastline. If this safe distance is not complied with, increased corrosion can be expected. These cases are excluded from the warranty.
- To prevent damage caused by animals such as rodents or insects, all cable ducts must be properly sealed.
- The hydraulic lines from the heat pump can transmit structure-borne noise. Therefore, structure-borne noise decoupling should be provided, e.g. with sound-insulating hoses.

A strainer is located in the outdoor unit. At least one sludge and magnetite separator must be installed in the heating return.

Flat roof installation

Flat roof installation of the Belaria® pro is possible under the following conditions:

- Strict compliance with safety measures regarding flammable refrigerants (see below).
- All standards concerning statics, wind load and access to roofs must be complied with. The outdoor unit must be firmly bolted onto the substructure (e.g. concrete base). The heat pump must be prevented from tilting.
- Minimum distance of the heat pump to the roof edge: 1.5 m (personal protection) + 0.6 m (working area refrigeration circuit).
- Accessibility for maintenance and repair work must be ensured. For work on the heat pump, a measuring case and test equipment, refrigerant bottle, etc. must be transported to the site, amongst other things. In addition to the safety equipment (fall protection devices, anchoring devices, etc.), this must also be taken into account for skylights, stairs, railings, etc.
- At exposed installation locations prone to wind load, e.g. on building roofs, the surface load on the upper horizontal cover surface of the heat pump caused by wind suction must not exceed a value of 1800 N/m². The heat pump casing might be damaged if this value is not complied with.
- The permitted surface load must be determined in accordance with the specifications of standard EN 1991-1-1. Compliance must be checked by a qualified specialist. A professional inspection of the actual conditions on site is mandatory and must be carried out by a qualified specialist.

- When planning and installing the heat pump in locations exposed to wind load, please contact your sales consultant in good time.
- Notice on installing the cover: If the cover of the heat pump has been removed, it must be properly reinstalled after the work has been completed. Make sure that the cover is fully connected to the heat pump using all the screw holes provided, to ensure stability and tightness.
- The heat pump contains electrically operated components and must be integrated in the structural lightning and surge protection for roof structures.

Safety measures to be complied with

- There must be no building openings (windows, doors, shafts, ventilation openings, etc.) within a radius of 1 m from the outdoor unit and no potential ignition sources must be present.
- Wall ducts into the building must be airtight.
- The outdoor unit must not be placed in or near floor recesses.
- The outdoor unit must not be placed closer than 1 m to the boundary of the property. Country-specific regulations must be observed.
- The air intake and air exhaust sides must not be narrowed or blocked. The air exhaust side must be unobstructed (> 2 m).
- The condensate is allowed to be directed into a shaft. A siphon must be installed upstream of the connection to the down-pipe. The siphon must be located inside the building.

Indoor unit

- The installation location must be selected in accordance with the valid requirements and directives.
- The indoor unit must be installed in a room protected against frost, by an approved specialist company. Room temperature must be between 5 °C and 25 °C.
- Installation in wet rooms, dusty rooms or rooms with a potentially explosive atmosphere is not permitted.
- To minimise vibration and noise inside the building, the inside of the heat pump should be isolated as well as possible from the building structure. The screed must be recessed around the indoor unit. For example, indoor units should never be installed on lightweight ceilings/floors.
- The connections for the heat pump or heating flow are located at the bottom of the Belaria® pro comfort indoor unit and at the top of the Belaria® pro compact.
- The connections for hot and cold water as well as for the hot water circulation are also located on top in the Belaria® pro compact.
- Due to the accessibility to the hydraulic system, the distances must be maintained on all sides (see Dimensions/Space requirements).

Electrical connections

- The electrical connection must be carried out by a qualified technician and registered with the responsible energy supply company. The relevant electrical installation company is responsible for ensuring that electrical connection is carried out in accordance with standards and that safeguard measures are put in place.
- The mains voltage at the connection terminals of the heat pump must be 400 V or 230 V ± 10 %. The connection lines specified in the technical data must be checked by the electrical company carrying out the work depending on the line length, the routing type and the type of line.
- A fault-current circuit breaker is recommended. Country-specific requirements must be complied with. If the “fault-current circuit breaker” safeguard measure is implemented by the electrical company, a separate fault-current circuit breaker is recommended for the heat pump.
- This fault-current circuit breaker must be of the all-current-sensitive type B ($I_{\Delta N} \geq 300$ mA). The specified RCCB types apply to the heat pump regardless of externally connected components (refer to assembly instructions, data sheets).
- Owing to the starting currents that occur, circuit breakers with a type “C” or “K” tripping characteristic are to be used for the main circuit.
- For the control circuit and additional electric heating (if present), circuit breakers with a type “B” or “Z” tripping characteristic are sufficient.
- The electrical connection and feeder lines must be copper cables.
- Please refer to the wiring diagrams for electrical details.
- The wall feedthrough should slope down from the inside to the outside.
- To avoid damage, the opening should be padded on the inside or, for example, lined with a PVC pipe.
- After installation, the wall opening must be sealed with a suitable sealing compound on site, observing the fire protection regulations.

Routing of the hydraulic connection lines

- If the hydraulic connection lines are laid in the ground, this must be done in a protective tube. For example, this can be a PVC pipe with a diameter of 150 mm.
- Wall ducts must be sealed to the outside on site.
- After the hydraulic connection lines have been laid, they must be checked for damage and re-insulated. In case of cooling, condensate can form on the pipes.
- The hydraulic connection lines must be laid decoupled from the building and must never be laid flush-mounted.
- Care must be taken to ensure that water pipes do not pass through the sleeping or living areas.
- Shut-off valves must be installed on site in accordance with the corresponding hydraulic diagram. The shut-off valves are not allowed to be opened until immediately before commissioning.

- The danger of frost damage must be taken into account if there are prolonged power outages.
- False flow rates as a result of incorrect dimensions of the pipework, incorrect fittings or improper pump operation can cause damage to the heat pump.

Room cooling

- Room cooling can be provided by fan convectors and is recommended. The connection lines for the fan convectors must have condensation-proof insulation. In addition, the condensate from the fan convectors must be drained off.
- If panel heating is used for room cooling, various criteria such as temperatures below the dewpoint or the temperature profiles must be allowed for, and can lead to costly consequential damage in the case of inadequate planning or incorrect use. We recommend that you consult Hoval.

Further guidelines see “Engineering”

Connection on drinking water side

- The hydraulic connection is made according to the information in the corresponding diagrams from Hoval.
- According to the Drinking Water Regulation and DIN 50930-6, the domestic hot water storage tank is suitable for normal drinking water (pH value > 7.3).
- The connection piping can be made using galvanised pipes, stainless steel pipes, copper pipes or plastic pipes.
- The connections must be made pressure-tight.
- The safety devices tested for the components in accordance with DIN 1988 and DIN 4753 must be installed in the cold water pipe.
- The 10 bar operating pressure stated on the data plate is not allowed to be exceeded. Install a pressure reducing valve if necessary.
- A suitable water filter must be installed in the cold water pipe.
- A water softener must be installed if the water is hard.

Installation on heating side

- All pertinent laws, regulations and standards for heating house pipework and for heat pump systems must be complied with.
- A strainer is located in the outdoor unit. At least one sludge and magnetite separator must be installed in the heating return.
- The safety and expansion devices for closed heating systems must be provided in accordance with EN 12828.
- Dimensioning of the pipework must be done according to the required flow rates and given pressure drops.
- Ventilation possibilities must be provided at the highest points and drainage possibilities at the lowest points of the connection lines.
- To prevent energy losses, the connection lines must be insulated with suitable material in accordance with local regulations.

Transport and storage

- When removing the packaging, check the outdoor unit for damage. If the outdoor unit was damaged during transport or storage, contact Hoval customer service, a service partner or a licensed specialist immediately. They must carry out a leak test with a suitable leak detector. In the event of a leak, the outdoor unit must be repaired.
- Store the outdoor unit in a cool place without fire hazard and without direct exposure to heat sources. The ambient temperature must not exceed 43 °C.
- The same regulations apply for storage as for installation (no recesses, ventilation pipes, ignition sources in the storage area).
- The outdoor unit must not be stored in closed rooms, cellars or garages.
- The outdoor unit is only allowed to be stored outdoors.
- During transport, ensure sufficient ventilation in the closed vehicle, also when parking and stopping.
- Storage in passageways, escape routes or in front of entrances or exits is not permitted.
- Ignition sources such as naked flames, switched-on gas appliances, electric heaters, etc. must be kept away from the unit.
- Transport and storage only in upright position. Protect from mechanical damage and from falling over or falling down (make sure the load is secure).
- To prevent damage during transport, the outdoor unit should be moved to its final installation location as far as possible in packed state on the wooden pallet with a forklift or lift truck.
- Transport by crane: The outdoor unit can be lifted by a crane and carried to the installation site. For this purpose, there are three stiffening brackets below the cover with openings for the passage of the transport straps.

Prerequisites for commissioning

- Commissioning at cold outdoor temperatures is only possible if the system is pre-heated on site (e.g. with an electric bake-out device). During commissioning, the room temperature of the heated rooms must be at least 15 °C (compressor operation is not possible below this temperature, as there would be too little energy for defrosting). If a buffer storage tank is provided, its heating water temperature is not allowed to be less than 20 °C during commissioning.
- A heat pump should not be used for drying out of the building (screed heating), as this can significantly reduce the service life of the device. Alternatively, heating via a mobile heating station or E-set is a sensible option. This is particularly true for air/water heat pumps, since the heating output here is strongly dependent on the outdoor temperature and drying out of the building is not possible at temperatures below the frost line in the building carcass.

Hoval quality.
You can count on us.

Hoval is one of the leading international companies for heating and indoor climate solutions. Drawing on more than 80 years of experience and benefiting from a close-knit team culture, the Hoval Group delivers exciting solutions and develops technically superior products. This leadership role requires a sense of responsibility for energy and the environment, which is expressed in an intelligent combination of different heating technologies and customised indoor climate solutions.

Hoval also provides personal consultations and comprehensive customer service. With around 2500 employees in 15 companies around the world, Hoval sees itself not as a conglomerate, but as a large family that thinks and acts globally.

Hoval heating and indoor climate solutions are currently exported to more than 50 countries.

Responsibility for energy and environment

Your Hoval partner

Liechtenstein

Hoval Aktiengesellschaft
9490 Vaduz
+423 399 24 00
hoval.com

United Kingdom

Hoval Ltd.
Newark Notts. NG 24 1JN
+44 1636 672 711
hoval.co.uk