

Hoval Belaria® pro

Important product information on:
Hoval Belaria® pro (20,25)

Important safety instruction

The heat pump (outdoor unit) is only allowed to be placed outdoors and under no circumstances indoors.



The outdoor unit is filled with the non-toxic, odourless and colourless but inflammable refrigerant R290 (propane), which is heavier than air. If this escapes, there is a danger of fire/explosion.

- All potential sources of ignition must be kept at least 1 m away in all directions (depending on the local conditions and the existing ventilation level)
- Smoking and the use of naked flames is prohibited in this area.



Thank you for the trust you place in Hoval products!

This leaflet contains important information required for professional installation of the heat pump. Thank you for following this product information. In addition, please also refer to the engineering guidelines and installation instructions.

- There must be no building openings (windows, doors, shafts, ventilation openings, etc.) within a radius of 1 m from the outdoor unit and no potential ignition sources must be present.
- Window balustrades must be higher than the upper edge of the outdoor unit in the protection area!
- Wall ducts into the building must be airtight.
- The outdoor unit must not be placed in or near floor recesses.
- The outdoor unit must not be placed closer than 1 m to the boundary of the property. Country-specific regulations must be observed.
- The air intake and air outlet sides must not be narrowed or blocked. The air outlet side must be unobstructed (> 2 m).
- In order to ensure accessibility during maintenance, a clearance of at least 600 mm upwards must be maintained.
For any service work, the minimum clearances at the rear and sides of the heat pump must be observed.
- Installation in wall niches is not recommended (air short circuit, sound reflection).

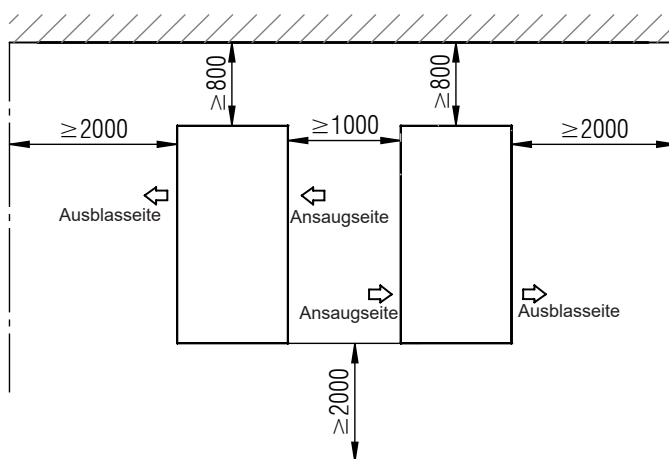
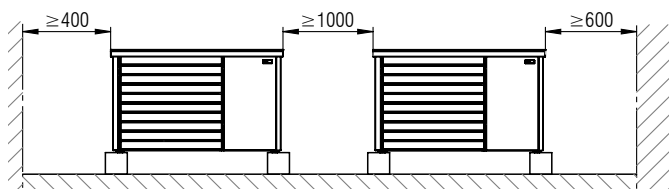
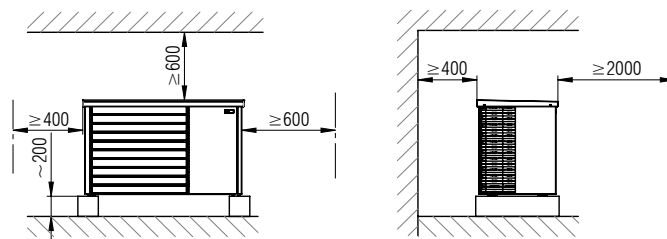

Floor plan – protection area when installed in front of a wall

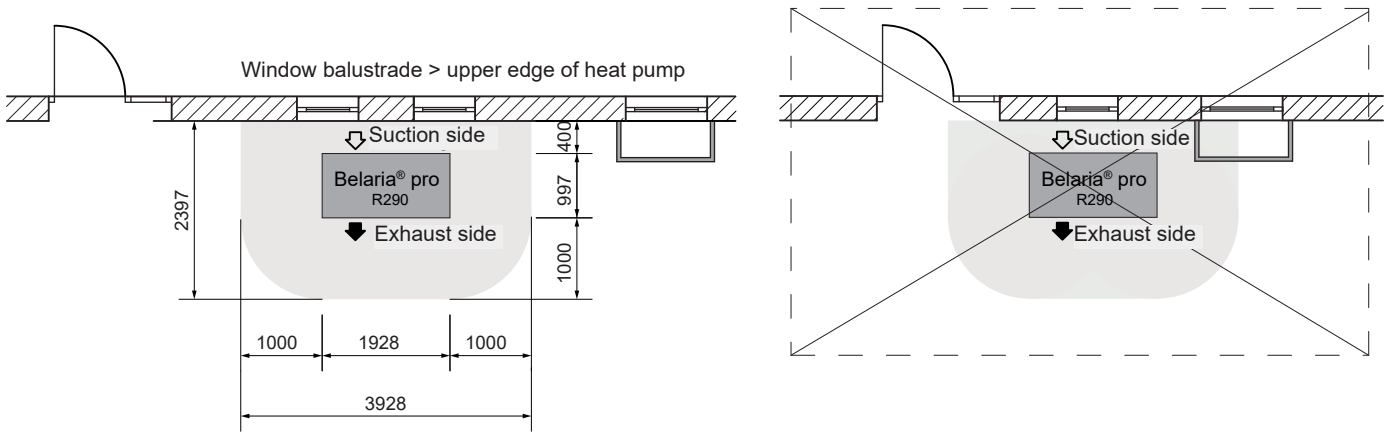

View – protection area when installed in front of a wall

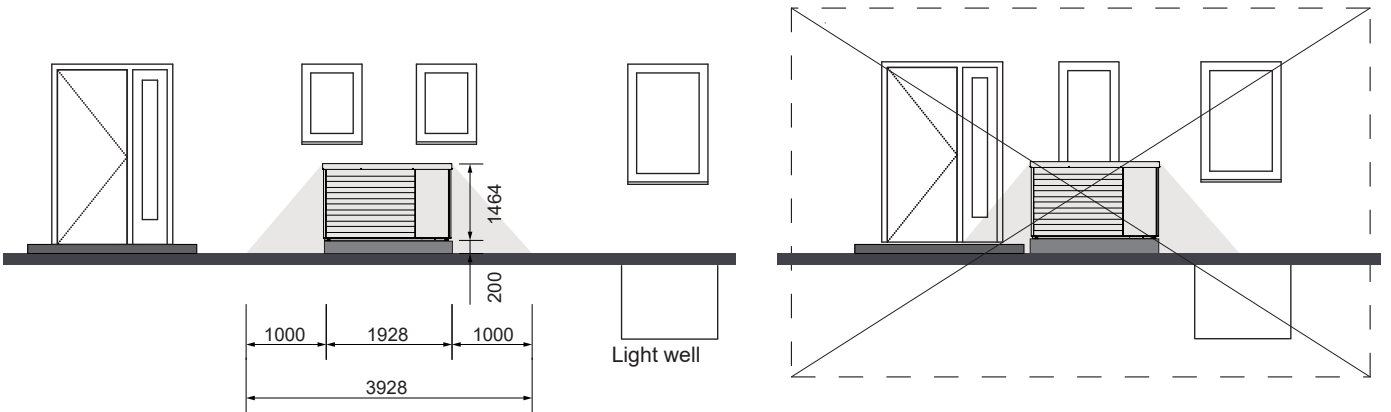

Floor plan – protection area when installed outdoors

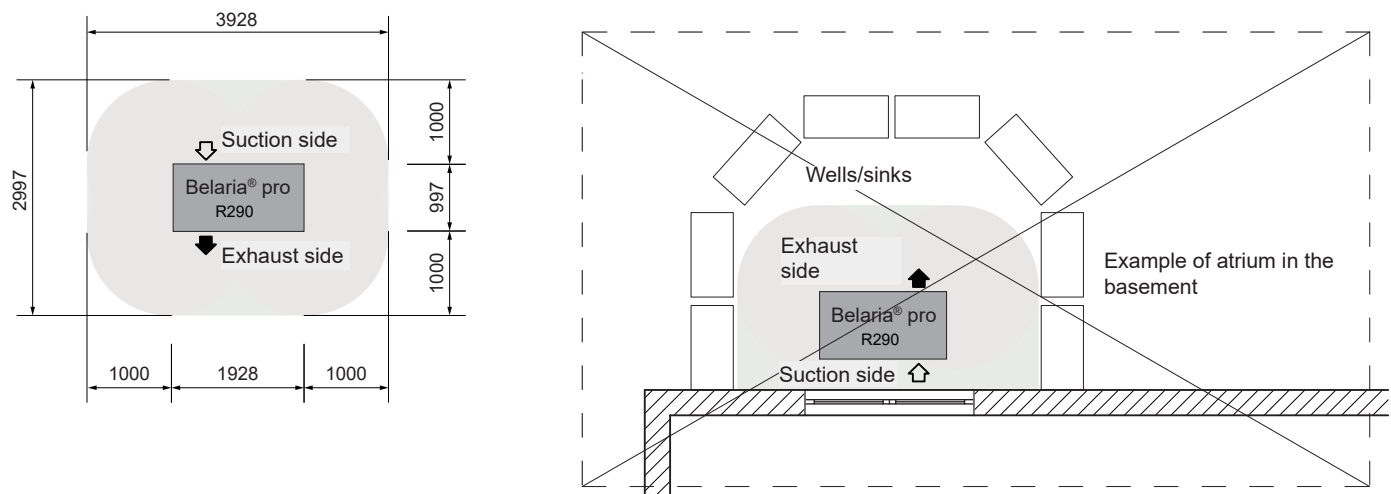

Important information on roof installations:

If the Belaria® pro is installed on a flat roof, the following points must be observed in addition to strict compliance with safety measures regarding flammable refrigerants (see page 1):

- All standards concerning statics, wind load and access to roofs¹⁾ must be complied with.
The outdoor unit must be firmly bolted onto the substructure (e.g. concrete base).
The heat pump must be prevented from tilting.
- Accessibility for maintenance and repair work must be ensured.
For work on the heat pump, a measuring case and test equipment, refrigerant bottle, etc. must be transported to the site, amongst other things. In addition to the safety equipment (fall protection devices, anchoring devices, etc.), this must also be taken into account for skylights, stairs, railings, etc.
- The heat pump contains electrically operated components and must be integrated in the structural lightning and surge protection for roof structures.
- For the installation of Belaria® pro on the roof, a maximum height of 15 m above the ground is permitted. This height is measured from the floor to the roof edge where the heat pump is installed. It should be noted that a safety valve with a response pressure of 2.5 bar is fitted in the heat pump.
- In addition, detailed analyses are required for installations over 15 m, which take into account the wind load, the system pressure and securing the system on the roof. Additional on-site measures must be implemented to ensure the safety of the heat pump.

¹⁾ e.g. ÖNORM B 3417 Safety equipment and classification of roof surfaces for use, maintenance and repair

Floor plan flat roof – protection area

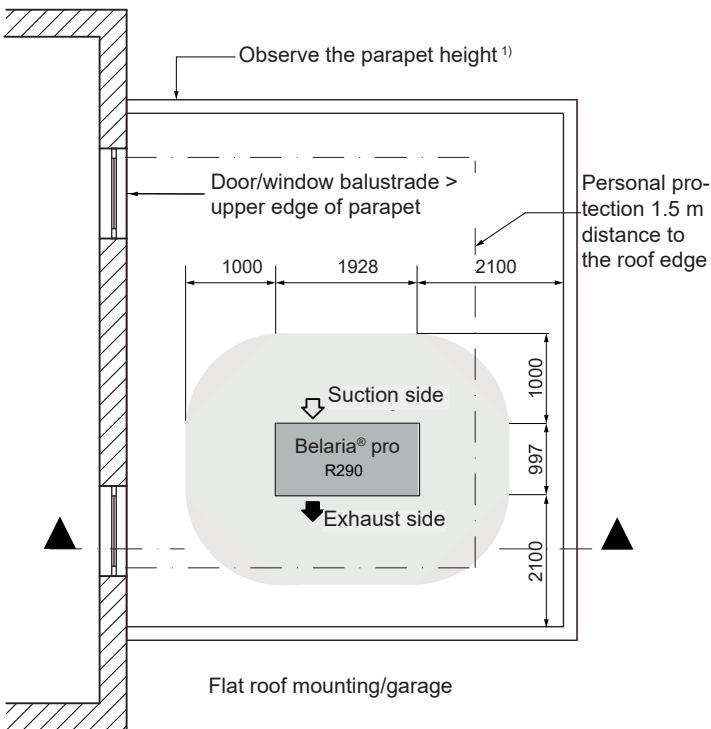

Section flat roof – protection area

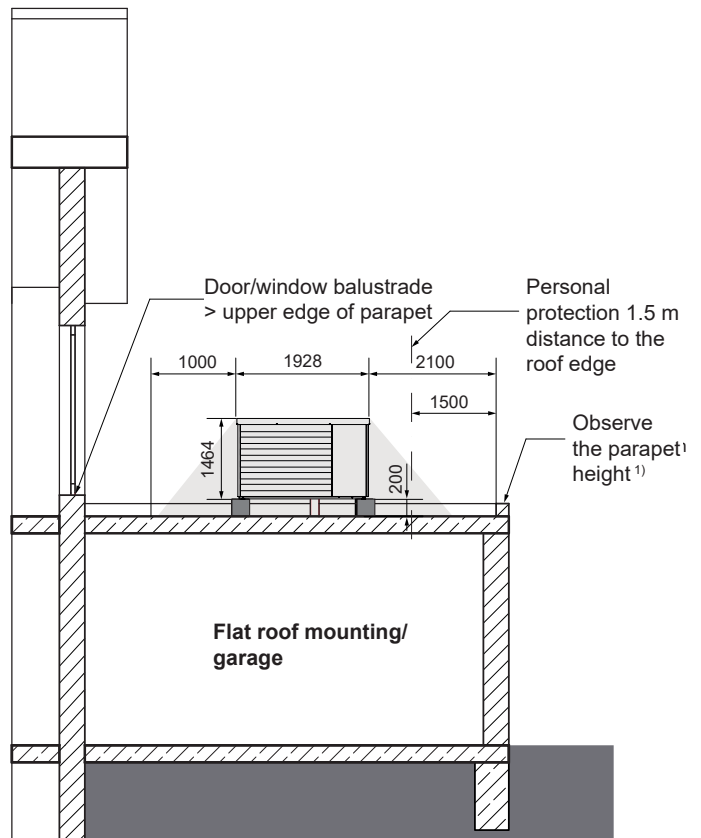

¹⁾ In case of flat roof installation, the parapet must not represent a potential sink in which refrigerant could accumulate. No ignitable mixture is allowed to form.

Attachment of the outdoor unit from the “inside/bottom” (grey area) of the heat pump using the supplied clamps.
The clamps are not visible. It is necessary to remove the cladding sections.

Strip foundation

Plan
(view from above)

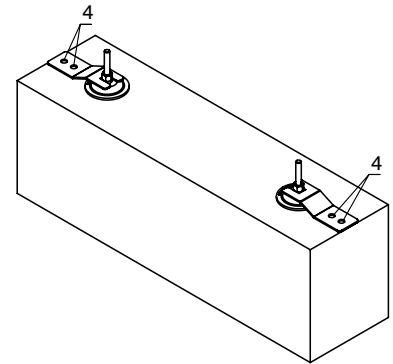
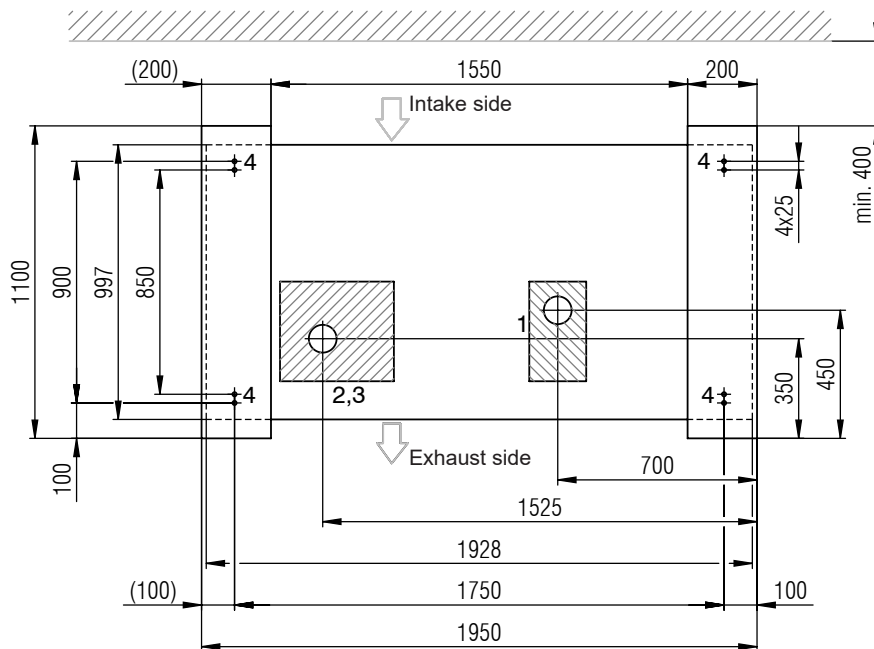

Floor plate

Plan
(view from above)

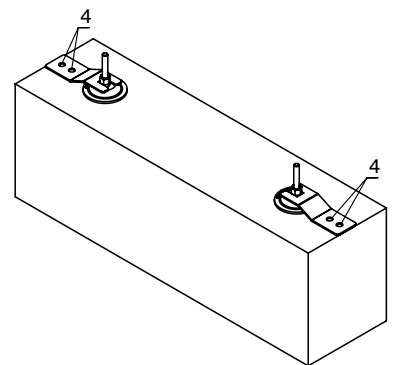
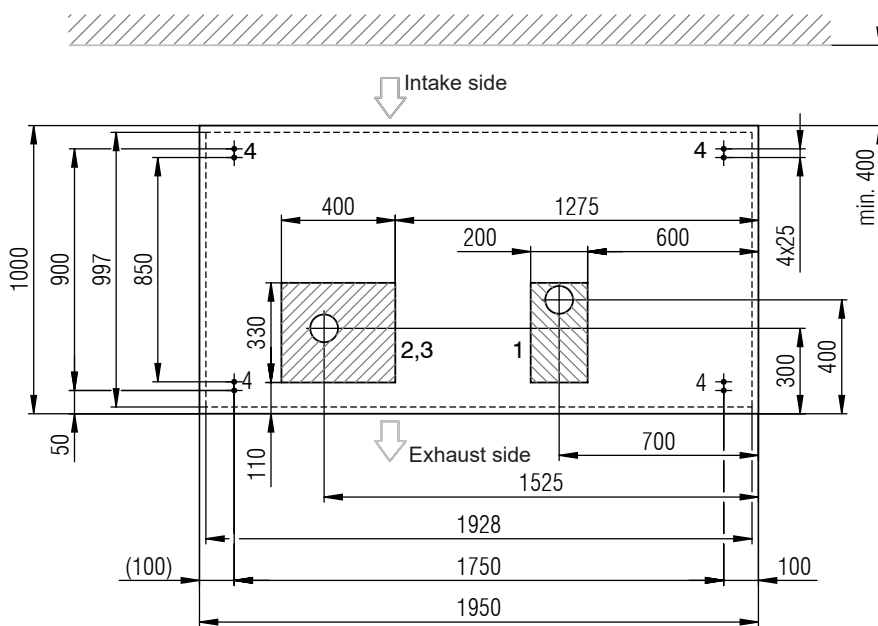

- Possible area for empty tubes in the strip foundation / floor plate
- Possible area for condensate drain in the strip foundation / floor plate

- 1 Condensate drain area
- 2 Area Flow hydraulics Return hydraulics
- 3 Electrics area
- 4 Attachment points M8 Belaria® pro (dowels in scope of delivery)

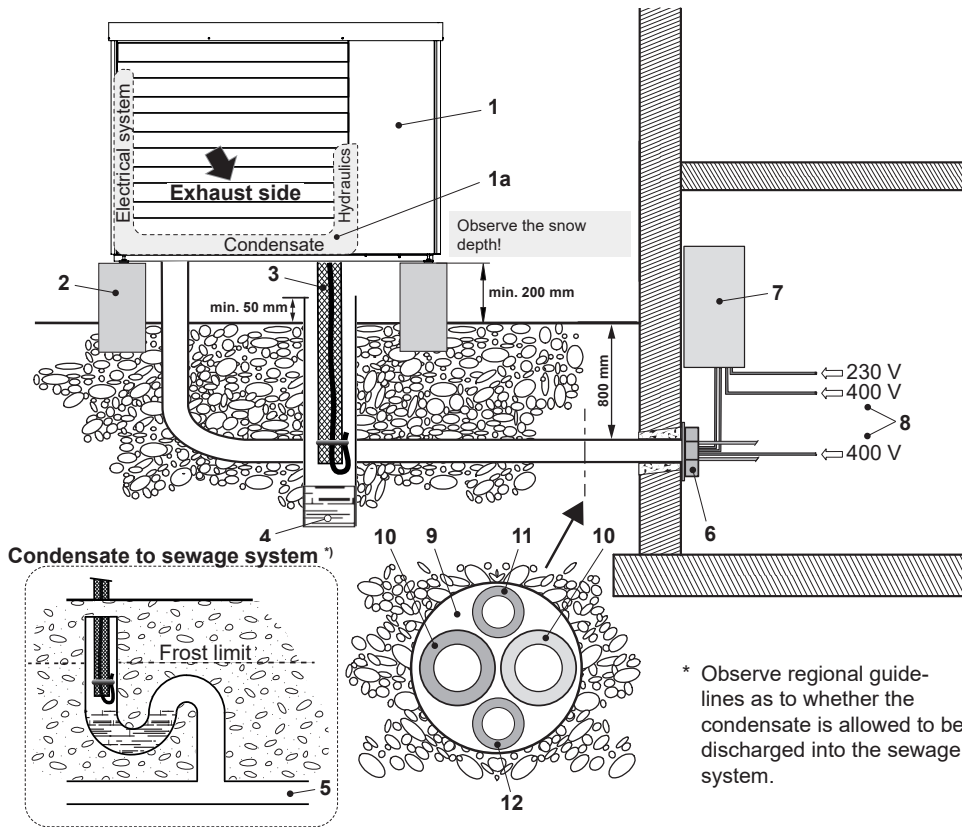

- 1 Outdoor unit
- 1 a Space for connection of hydraulics (flow + return), condensate drain and electrics.
- 2 Strip foundation
- 3 Condensate drain heat pump Ø 28 mm, drain pipe DN 100
- 4 Variant 1: Seepage (duct/gravel layer)
- 5 Variant 2: Discharging into the sewage system (penetration into the soil must be made leak-tight)
- 6 Wall lead-through (hydraulic and electrical connections)
- 7 Electrical box
- 8 Main current: 3 x 400 V/50 Hz
Control current: 1 x 230 V/50 Hz
Electric heating element main current: 3 x 400 V/50 Hz
- 9 Network cables (optional)
- 9 Empty tube for hydraulics and electrics
- 10 Connection line flow + return
- 11 Empty tube for electrical connections for outdoor unit
- Main current outdoor unit: 3 x 400 V/50 Hz
- Control current outdoor unit: 1 x 230 V/50 Hz
- 12 Empty tube for data bus RS485

Drainage, condensate drain:

- Air heat pumps generate condensate during operation. This can amount to 15 litres per defrost cycle within 2 minutes for the outdoor unit of the Belaria® pro.
- The condensate drain must be frost-proof.
- If there is a risk of frost, a siphon must be installed in the shaft immediately before the condensate drain is introduced into the downpipe.
- The condensate drain pipe must be routed with a downhill slope. A siphon is only required if the condensate drain opens into a duct. This must be placed inside the building.
- The heat pump has a condensate drip tray incl. tray heating. The heating tape of the condensate tray heater has an excess length of approx. 1 m and must be inserted into the condensate drain (infiltration, drainage, condensate drain).

- The outdoor unit should be installed at a slight elevation compared to relief features in the immediate vicinity; the recommendation is at least 200 mm (expected snow depth).
- The hydraulic lines and the condensate drain are connected under the outdoor unit.
- The connecting lines for the electrics and hydraulics must be laid at least 800 mm below ground level.
- For efficiency reasons, the line length with the Belaria® pro between the calorifier and the indoor unit is not allowed to be more than 10 m.
- The maximum permitted single cable length is 30 m between the outdoor unit, via the indoor unit and the buffer storage tank. This must not be exceeded. In general, the customer must assess whether the next larger pipe dimension is more suitable due to the pressure drop
- A strainer is located in the outdoor unit. At least one sludge and magnetite separator must be installed in the heating return. A system water protection filter is recommended.
- We recommend the use of flexible, pre-insulated pipes of type WA-HP. Available with inner diameter DN 40.
- The connection tube must be sealed with an end cap.



- Store the outdoor unit in a cool place without fire hazard and without direct exposure to heat sources.
- The ambient temperature must not exceed 43 °C.
- The same regulations apply for storage as for installation (no recesses, ventilation pipes, ignition sources in the storage area).
- Pay attention to the centre of gravity when transporting! The centre of gravity of the system is not in the middle.
- The outdoor unit can be lifted by a crane and carried to the installation site. For this purpose, there are three stiffening brackets below the cover with openings for the passage of the transport straps.
- In particular, see all the information in the instructions for the unit.

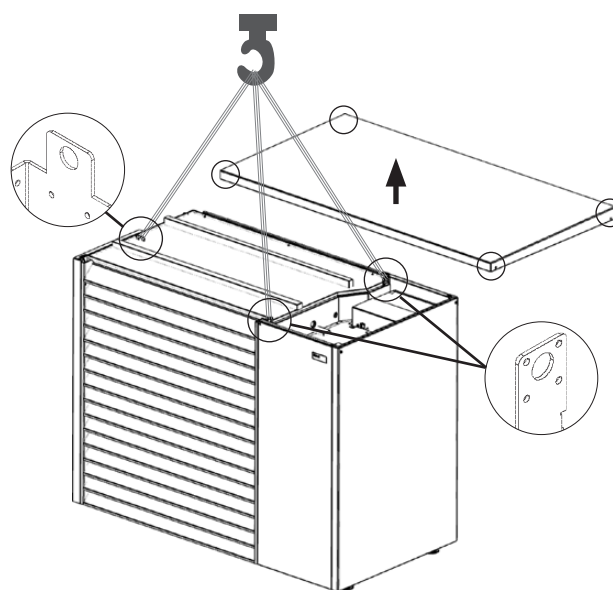

Centre of gravity

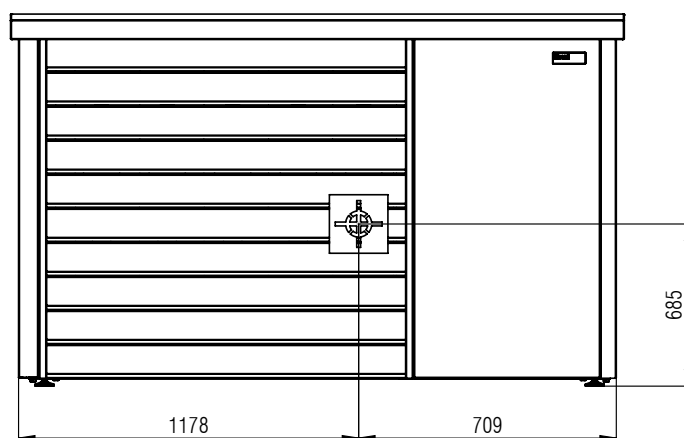
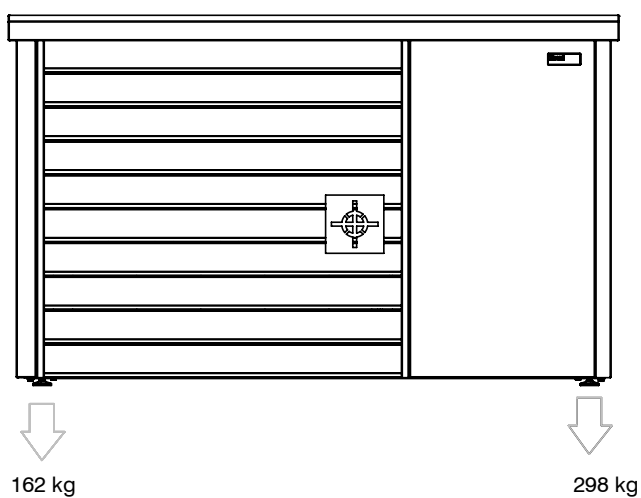

Installation of the indoor unit
(wall-mounted)
(Dimensions in mm)

Belaria® pro
Electrical box wall-mounted

To ensure good operability and accessibility to the electrical/hydraulic connections, a clearance of max. 1000 mm must be provided from the ground to the lower edge of the indoor unit.

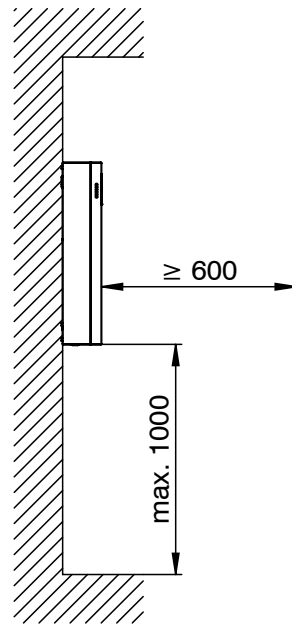
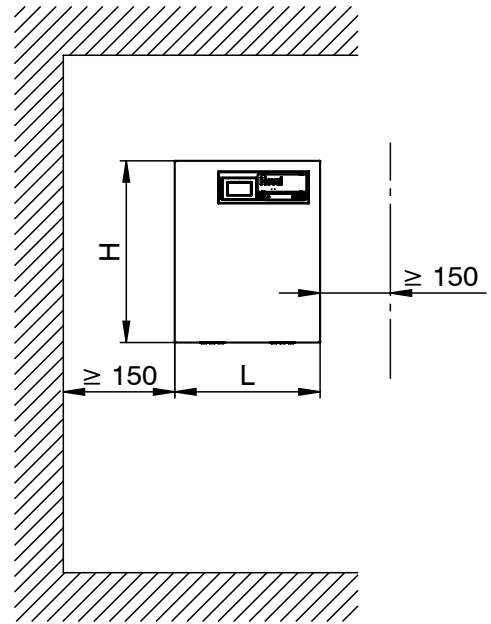

- The electrical installation company should be installed at an early stage. The hydraulic and wiring diagram must be forwarded to this company.
- The electrician must be informed that a special fault-current circuit breaker (common when using inverter compressors) must be installed for the main power supply cable (type B). See accompanying diagram.
- A “TN-S zeroing” (S stands for separate) can also be used instead of the fault-current circuit breaker. This means that the neutral conductor (N) and protective earth conductor (PE) are routed separately throughout the system. The decision as to which protective measure is to be applied lies with the electrical company carrying out the work or the technical connection conditions of the grid operator (TAB).
- To avoid static charge, the protective earth conductor must be connected properly.

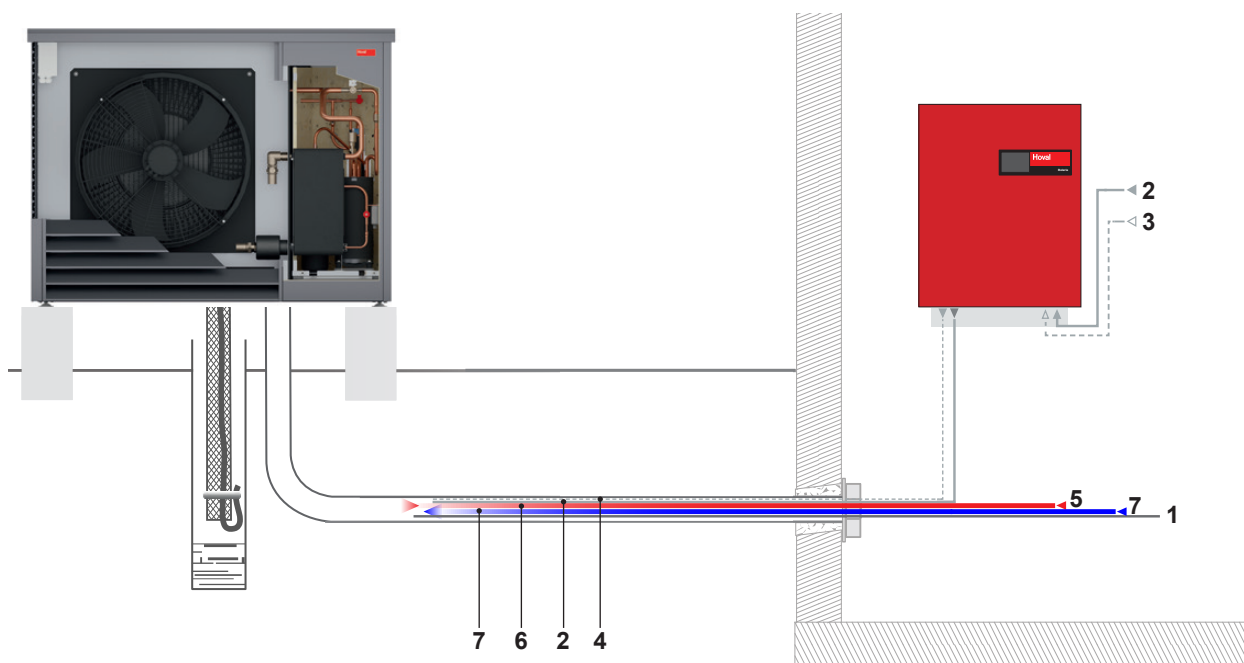

- 1 Main current:
3 x 400 V/50 Hz, 5-pin 400 V (4 mm²), fuse C20A
Fault-current circuit breaker (FI): type B, I Δ n \geq 300 mA (opt. zeroing)
- 2 Control current :
1 x 230 V/50 Hz, 3-pin 230 V (1.5 mm²), fuse B13A
Fault-current circuit breaker (FI): type A, I Δ n \geq 30 mA (opt. zeroing)
- 3 Network cables (optional):
RS485, (4-wire) 2 x 2 x 0.5 mm, Li2YCY
- 4 Data bus:
RS485, (4-wire) 2 x 2 x 0.5 mm, Li2YCY
- 5 Flow heating
- 6 Heat pump flow
- 7 Return

- Commissioning at cold outside temperatures is only possible if the system is preheated on site (e.g. with an electric bake-out device). During commissioning, the room temperature of the heated rooms must be at least 15 °C (compressor operation is not possible below this temperature, as there would be too little energy for defrosting).
If a buffer storage tank is provided, its heating water temperature is not allowed to be less than 20 °C during commissioning.
- A heat pump should not be used for drying out of the building (screed heating), as this can significantly reduce the service life of the device.
Alternatively, heating via a mobile heating station or E-set is a sensible option.
This is particularly true for air/water heat pumps, since the heating output here is strongly dependent on the outside temperature and drying out of the building is not possible at temperatures below the frost line in the building carcass.

Important:

Drying out of the building takes 21 to 28 days, depending on the type of screed used, and requires an enormously high energy input in the order of 20 - 25 kWh/m². Accordingly, the heating process for a common single-family home requires more than 3000 kWh of energy. Depending on the heat pump type, this means an operating time of more than 400 hours, which are usually operated at maximum output!



Hoval quality.
You can count on us.

Hoval is one of the leading international companies for heating and indoor climate solutions. Drawing on more than 80 years of experience and benefiting from a close-knit team culture, the Hoval Group delivers exciting solutions and develops technically superior products. This leadership role requires a sense of responsibility for energy and the environment, which is expressed in an intelligent combination of different heating technologies and customised indoor climate solutions.

Hoval also provides personal consultations and comprehensive customer service. With around 2500 employees in 15 companies around the world, Hoval sees itself not as a conglomerate, but as a large family that thinks and acts globally.

Hoval heating and indoor climate solutions are currently exported to more than 50 countries.

Responsibility for energy and environment

Your Hoval partner

Liechtenstein

Hoval Aktiengesellschaft
9490 Vaduz
+423 399 24 00
hoval.com

United Kingdom

Hoval Ltd.
Newark Notts. NG 24 1JN
+44 1636 672 711
hoval.co.uk