

**Buffer storage tank
EnerVal (100-300)**

- Steel buffer storage tank for the hydraulic integration of energy generators
- Thermal insulation made of polyurethane hard foam, foamed on the storage
- Removable foil casing in red
- (100): 2 connection sleeves Rp 1 ½", 2 connection nozzles R 1"
- (200): 5 connection sleeves Rp 1 ½"
- (300): 8 connection sleeves Rp 1 ½"
- 1 sleeve Rp ½" with thermometer and immersion sleeve mounted
- 2 sensor channels

Delivery

- Buffer storage tank with foil casing completely mounted and packed



**Buffer storage tank
EnerVal (500)**

- Steel buffer storage tank for the hydraulic integration of energy generators
- Thermal insulation made of polyurethane hard foam, foamed on the calorifier
- Removable foil casing in red
- 8 connection sleeves Rp 1 ½"
- 1 sleeve Rp 1 ½" for screw-in electrical heating inset
- 1 sleeve Rp ½" with thermometer and immersion sleeve mounted
- 2 sensor channels

Delivery

- Buffer storage tank with foil casing completely mounted and packed

Range EnerVal type		Nominal content l	Operating pressure bar
(100)	A ➤	117	3
(200)	B ➤	222	3
(300)	B ➤	283	3
(500)	B ➤	473	3
(800)		781	3
(1000)		922	3
(1500)		1416	3
(2000)		2032	3

**Buffer storage tank
EnerVal (800-2000)**

- Steel buffer storage tank for the hydraulic integration of energy generators
- Thermal insulation made of polyester fleece with foil jacket, colour red
- 10 connection sleeves G 2" (IT)
- 2 sleeves G 1 ½" (IT) for screw-in electric heating element
- 3 sleeves G ½" (IT) for sensor/thermometer
- Terminal strips for contact sensors
- 1 sleeve G 1" (IT) for circulation lance only with EnerVal (800,1000)
- 1 sleeve G 1" (IT) for ventilation
- Perforated separating plate in the central area for separation of the temperature zones
- Flow diversions permanently installed
- 13 insulated cover caps made of EPP hard foam, 2-piece (can be broken out)

Delivery

- Buffer storage tank with foil casing completely mounted and packed
- Insulated cover caps already installed (can be removed and broken out)

Buffer storage tank

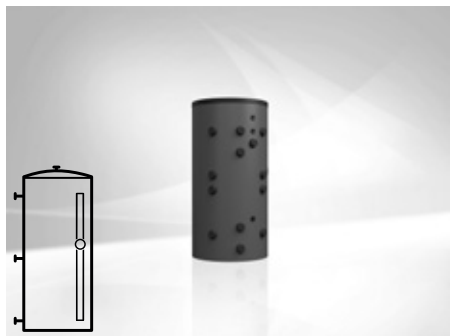

EnerVal (100-2000)

Steel container raw on the inside,
EnerVal (100-500) pre-installed,
EnerVal (800-2000) thermal insulation pre-
installed

EnerVal type		Nominal content l
(100)	A	117
(200)	B	222
(300)	B	283
(500)	B	473
(800)		781
(1000)		922
(1500)		1416
(2000)		2032

Part No.

7016 826
7013 681
7015 975
7015 976
7019 129
7019 130
7019 131
7019 132

Electric heating elements

see chapter "Electric heating elements"

Accessories

Protective tube immersion

sleeve set 200 1/2", 4 x
For installation of maximum 4 sensors
Nickel-plated brass
Installation length = 187 mm
Outer Ø: 18 mm, inner Ø: 16 mm
including 3 segment springs 90°,
1 Omega clamping spring

6061 045



Protective tube immersion sleeve SB280 1/2"

Nickel-plated brass
Installation length = 280 mm
Outer Ø: 9 mm, inner Ø: 7 mm

2018 837



Thermometer kit

for EnerVal (200-6000)
Thermometer 0-120 °C with
chromium plated edge and Hoval logo
Stem length: 80 mm, stem Ø: 9 (13) mm,
External Ø: 80 mm
incl. immersion sleeve 1/2" nickel-plated
brass, installation length: 200 mm,
external Ø: 16 mm, internal Ø: 15 mm
and clamping spring

6052 107



Inject lance

for EnerVal (200-500)
For horizontal installation in the
buffer storage tank.
For the decrease of the turbulence of
the attached water.
Screw-in depth: 450 mm
Connection: Rp 1 1/2"

6051 645

Services



Commissioning

Commissioning by works service or Hoval trained authorised serviceman/company is condition for warranty.

For commissioning and other services please contact your Hoval sales office.

Part No.

EnerVal (100-2000)

Type		(100)	(200)	(300)	(500)	(800)	(1000)	(1500)	(2000)
• Volume	litres	117	222	283	473	781	922	1416	2012
• Max. operating/test pressure	bar	3/4	3/4	3/4	3/4	3/4	3/4	3/4	3/4
• Min. operating temperature	°C	5	5	5	5	20	20	20	20
• Max. operating temperature	°C	95	95	95	95	95	95	95	95
• Thermal insulation PU rigid foam, foam-lined	mm	50	50	75	75	-	-	-	-
• Thermal insulation polyester fleece	mm	-	-	-	-	150	150	150	150
• Thermal insulation λ	W/mK	0.027	0.027	0.027	0.027	0.04	0.04	0.04	0.04
• Fire protection class		B2	B2	B2	B2	B2	B2	B2	B2
• Heat loss at 65 °C	W	51	53	54	72	119	130	158	185
• Transport weight	kg	41	59	79	111	165	180	284	515
• U value	W/m ² K	0.359	0.359	0.279	0.296	0.360	0.341	0.328	0.311
• Dimensions		see table of dimensions							

Outflow velocity flow lance DN 40

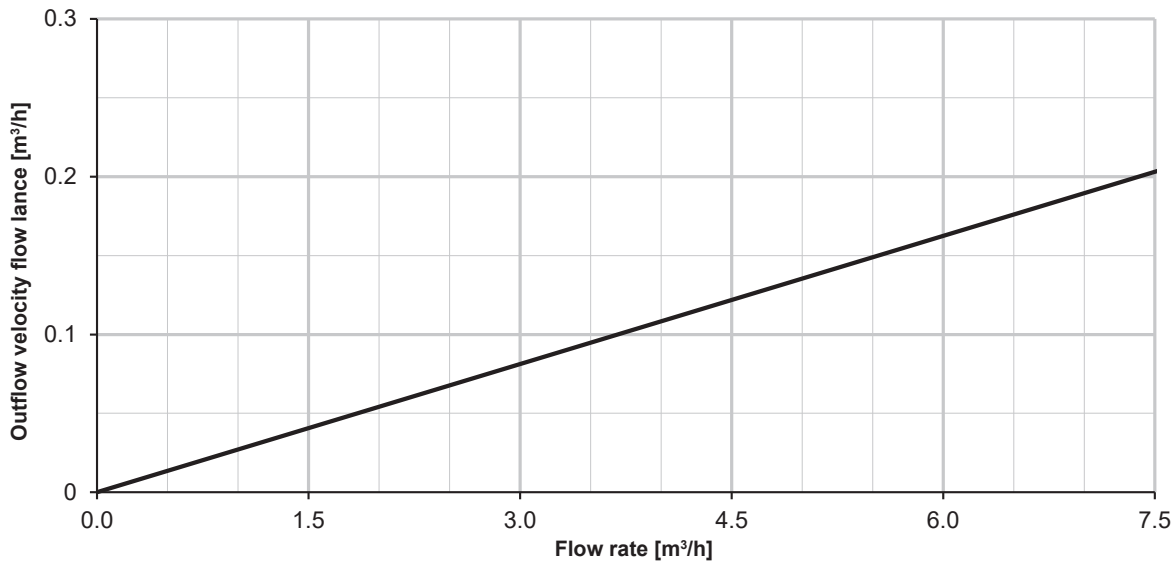

Velocity in the connection nozzles and inflow velocity with flow deflection in the EnerVal (800-2000)

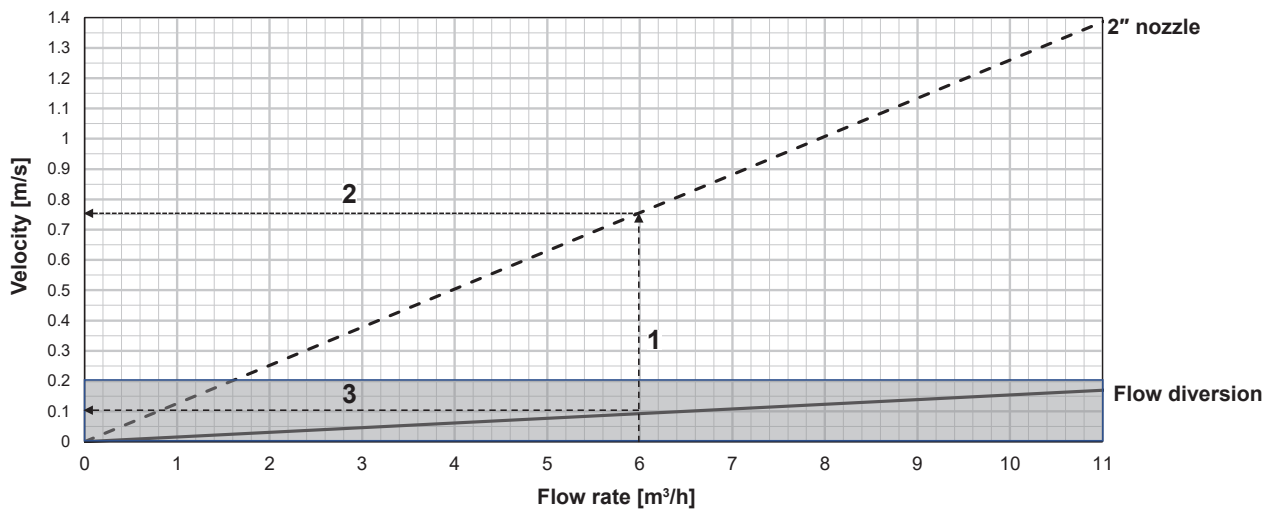

- 1 = flow rate
- 2 = velocity in the connection nozzles
- 3 = inflow velocity with flow deflection in the EnerVal

Example of inlet velocity distribution by flow diversions

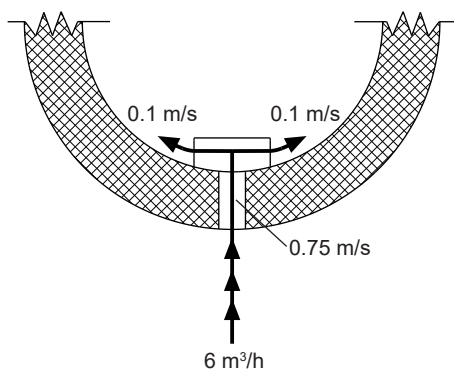

EnerVal (100)
(Dimensions in mm)

EnerVal (200-500)

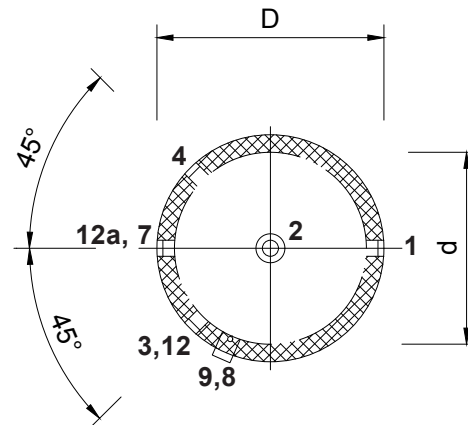
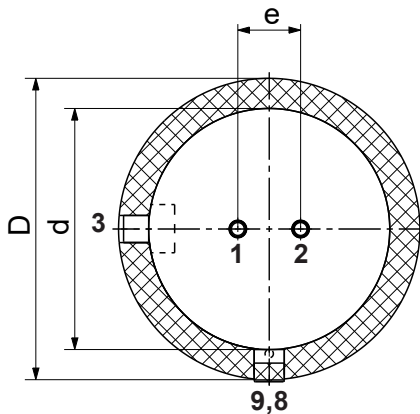
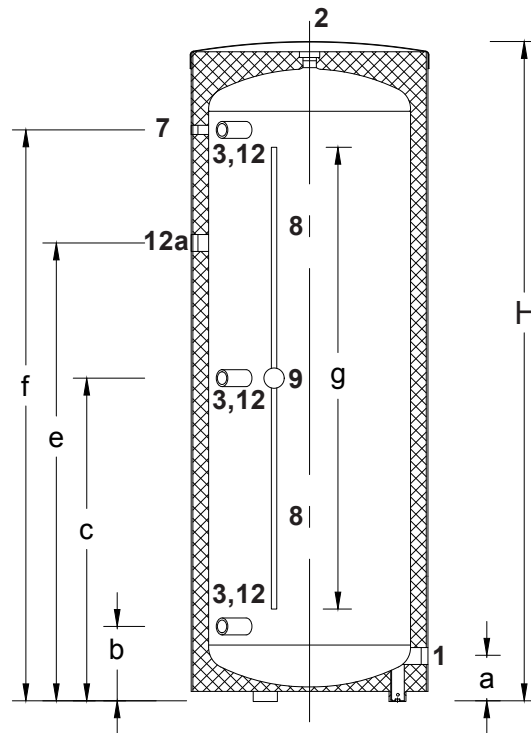
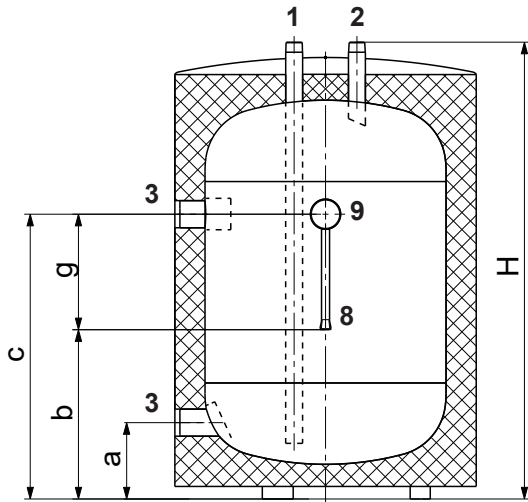

Type (100) Type (200-500)

- 1 Heating connection return discharge
- 2 Heating connection flow discharge
- 3 Heat generator connection flow/return
- 4 Heat generator connection flow/return 3 x, only with EnerVal (300,500)
- 7 Sleeve with mounted immersion sleeve and thermometer
- 8 Sensor channel inner Ø 11 mm
- 9 Removable cap (60 mm) for positioning the sensor in the sensor channel
- 12 Connection for screw-in electric heating element
- 12a Additional connection for screw-in electric heating element, only for EnerVal (500)

- R 1" (ET)
- R 1" (ET)
- G 1½" (IT)
- G 1½" (IT)
- G 1½" (IT)
- G 1½" (IT)
- G 1½" (IT)
- G 1½" (IT)

1 + 2 For EnerVal (100), suitable for direct installation of an armature group LG/HA 25-2 and 32-2

EnerVal type	D	d	H	a	b	c	e	f	g	Tilting dimension
(100)	600	480	910	152	337	567	125	-	230	985
(200)	600	480	1440	152	300	720	-	1140	860	1560
(300)	650	480	1780	152	300	890	-	1479	1285	1895
(500)	750	597	1921	127	220	946	1400	1670	1360	2025

Variation because of the production tolerance possible
Dimension +/- 10 mm

EnerVal (800-2000)
(Dimensions in mm)

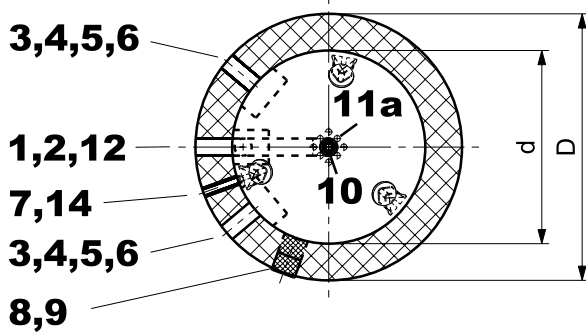
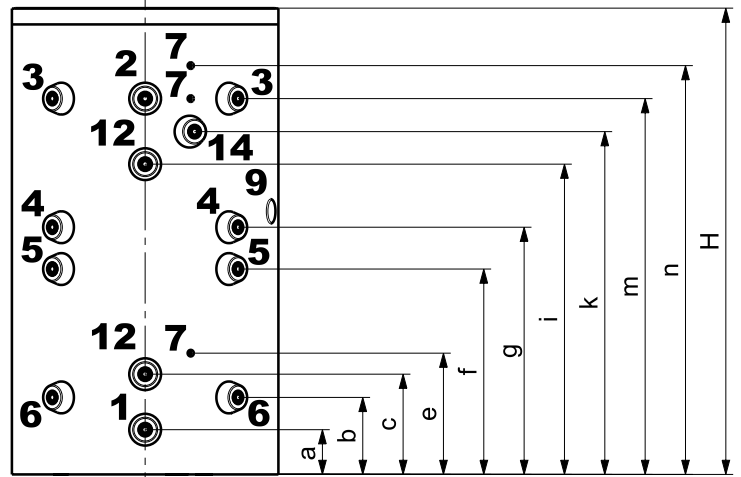
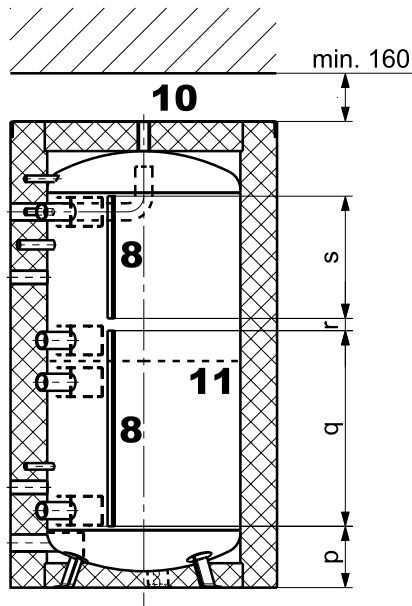

Variation because of the production tolerance possible
Dimension +/- 10 mm

- 1 Heating connection return discharge (inflow restrictor) G 2" (IT)
- 2 Heating connection flow discharge (single-layer elbow pipe) G 2" (IT)
- 3 Heat generator connection flow top (inflow restrictor) G 2" (IT)
- 4 Heat generator connection return top (inflow restrictor) G 2" (IT)
- 5 Heat generator connection flow bottom (inflow restrictor) G 2" (IT)
- 6 Heat generator connection return bottom (inflow restrictor) G 2" (IT)
- 7 Sleeve for immersion sleeve, thermostat or thermometer G 1/2" (IT)
- 8 Sensor terminal strip 2 x
- 9 Removable cap (100 mm) for positioning the sensor
- 10 Possible air vent G 1" (IT)
- 11 Separating plate
- 11a Holes in the separating plate 12 x
- 12 Connection for electric heating element G 1 1/2" (IT)
- 14 Connection for circulation lance, **attention:** only for type (800,1000) G 1" (IT)

EnerVal type	D	d	H	a	b	c	e	f	g	i	k	m	n	p	q	r	s	Tilting dimension
(800)	1090	790	1907	183	315	410	496	840	1011	1269	1402	1537	1672	251	800	50	500	1945
(1000)	1090	790	2197	183	369	468	569	970	1171	1472	1596	1759	1942	370	800	100	500	2230
(1500)	1300	1000	2135	220	368	451	549	941	1137	1431	-	1699	1839	339	800	100	500	2179
(2000)	1500	1200	2145	220	382	430	529	928	1127	1425	-	1672	1839	350	800	80	500	2210