



**Hoval**

# Decentralised indoor climate systems

At a glance

Efficient | Flexible | Reliable

Hoval | Responsibility for energy and environment

# Hoval – heating and climate technology for industrial, commercial and leisure applications.

**With over 75 years' experience, Hoval is one of the leading international companies for indoor climate systems. For our customers, we develop modern, decentralised heating, cooling and ventilation solutions for large halls for a diverse range of applications.**

From workshops, production halls and logistics centres to aircraft hangars, shopping centres and swimming pools – our experts can design indoor climate systems tailored to your individual requirements.

And the best part: the flexibility of our systems means they can easily be adapted to meet your changing needs in the future, giving you excellent long-term results.

As a specialist in universal systems for heating, cooling and ventilation, we assist our customers at every stage of the system lifecycle at their facility – from planning and operation right through to modernisation. In doing so, we help our customers to benefit from energy-efficient solutions and first-class air quality both today and tomorrow.



# The perfect climate in every hall.

**The perfect climate and pleasant, performance-enhancing conditions for both work and well-being in halls for industrial, commercial and leisure applications. The new generation of decentralised indoor climate systems from Hoval makes it all possible.**

The modular ventilation, heating and cooling systems consist of units distributed within the hall space with demand-driven control. Installed in a select number of specific locations, these systems ensure optimum climate conditions throughout the entire hall, even where different requirements are involved. The supply and extract air handling units, supply air units and recirculation units are equipped with optimised air distribution and, if desired, their own heat and cold generation system.

## Hoval indoor climate systems overcome any challenge

- Decentralised and modular
- Efficient and economical
- Clean and ecological
- Competent and reliable

## A single system – the interplay of perfectly matched products

- **RoofVent®**  
Supply and extract air handling units for ventilating, heating and cooling high spaces with energy recovery.  
Additional variants:
  - with heat pump for decentralised heating and cooling
  - with gas condensing boiler for decentralised heating
  
- **TopVent®**  
Recirculation and supply air units for cost-effective heating and cooling of high spaces with recirculated or mixed air  
Additional variants:
  - as roof units for more space and undisturbed operation in the hall
  - with heat pump for decentralised heating and cooling
  - with gas condensing boiler for decentralised heating
  
- **ProcessVent**  
compact units for ventilating, heating and cooling production halls with highly efficient energy recovery from process air



## Decentralised and modular.

**We design our Hoval indoor climate systems as technically autonomous and energy-independent individual solutions.**

Quick and easy to plan, our systems can be perfectly integrated into virtually any environment without the need for structural measures.

And if things change in the future, our solutions simply develop along with your plans. Whether converting or expanding, the modular structure of the Hoval systems allows you to adapt to new challenges with minimal expense and low investment costs.

**Maximum practicality and perfectly matched – we tailor your indoor climate system to your exact specifications**

- Efficient air distribution with the integrated Air-Injector – reduced heat loss and no pressure drops in ducts
- Huge choice of units and specific designs for every application
- Completely preassembled, ready-to-connect systems for hassle-free installation, quick start-up and easy maintenance
- Compatible, open-interface components for easy connectivity to external connections and perfect integration with the building management system





## Efficient and economical.

**Hoval indoor climate systems are an easy and efficient solution. The patented Hoval Air-Injector air supply and distribution system helps reduce temperature stratification in the halls. The difference between the room temperature under the roof and the outside temperature remains small and only a minimal amount of energy is lost through the roof.**

The Air-Injector’s powerful, efficient air distribution allows the components to cover a large operating area, meaning that only a relatively low air flow rate is required. Not only does this save on investment costs, but also on drive energy and running costs too. Potential energy savings for specific applications can quickly and easily be calculated using the Hoval calculation tool.

The ready-to-connect, pre-installed units with integrated measurement, control and regulation components also ensure cost-effective, quick and smooth system planning, installation and start-up of the systems.

### Efficient indoor climate systems are good for the environment – and your finances

- Ideal air supply and distribution for minimum energy loss and maximum comfort
- Connection of recirculation units optimised according to requirements
- “Air-Quality” operating mode for ventilation according to requirements
- Economical night cooling with temporarily adapted reduced air volume
- 24/7 cooling and overheating protection
- Hoval energy recovery – offering superior performance and even higher energy efficiency

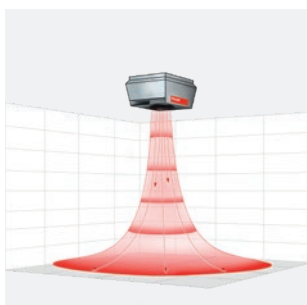

**Heating operation:** The supply air is warmer and thus lighter than the room air. The vertical inflow of air ensures that the heat reaches the areas where it is needed.



**Cooling operation:** The inflowing air is colder than the room air and sinks. To avoid draughts, it is injected horizontally.

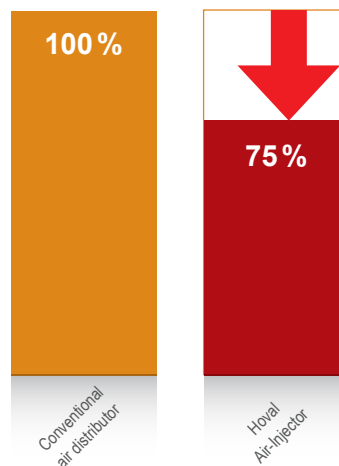

Compared to other systems, they often require far lower air flow rates to achieve the required and desired conditions.

# Clean and ecological.

**Hoval indoor climate systems create a comfortable climate and always ensure fresh air. By guiding the air streams separately in the plate heat exchanger, dirt and odours from the extract air are diverted directly outside, preventing contamination of the supply air.**

The individual indoor climate system units are installed on the ceiling or in the roof, distributed throughout the interior. Supply and extract air ducts are not required and there are no contaminated, difficult-to-clean pipes. Duct-free ventilation is therefore able to ensure maximum hygiene and comfort.

### **Fresh air at all times – a plus for the environment and your health**

- Renewable energy for heating and cooling
- Highly efficient energy recovery
- Fully separate air streams in energy recovery
- Clean supply air at all times, as difficult-to-clean air ducts are not required

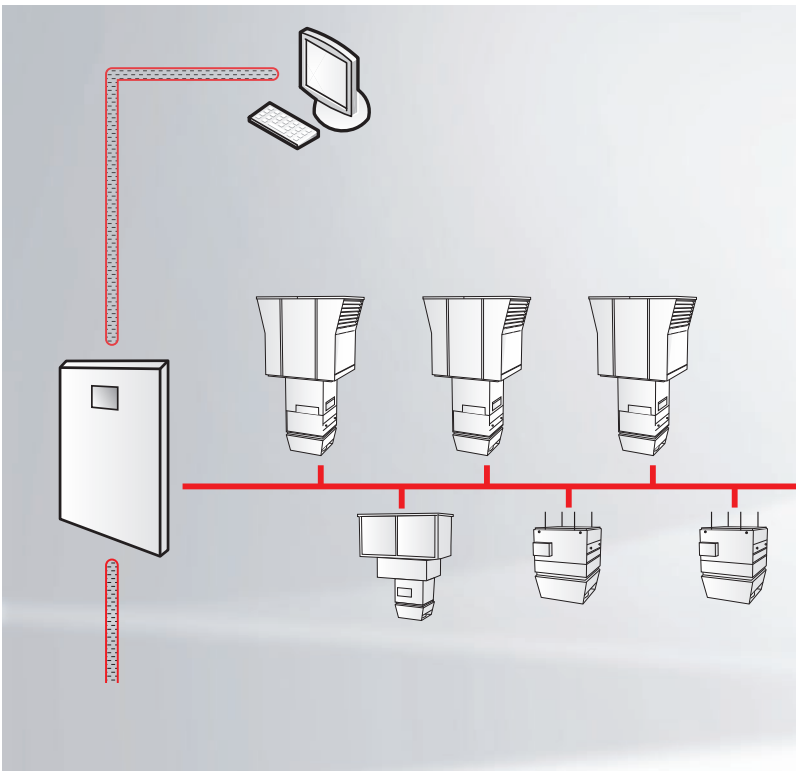

The zone-based control concept enables need-based ventilation, heating and cooling of indoor areas used for various purposes.



## Competent and reliable.

Right from the planning stage, our specialists get to grips with your system's unique requirements profile. Drawing on their expertise and years of experience, they bring together the best possible units and components from across the Hoval product ranges to create your tailor-made indoor climate system. Energy efficient and cost effective, easy to operate, environmentally friendly, easy to service and good for your staff.

### You can rely on Hoval – over the entire lifecycle of our products

- Ready-to-connect systems with pre-defined hydraulic and electric connection points for hassle-free planning
- Compact and simple function units with easy, clearly defined operating modes for smooth integration in any building
- Patented control algorithms with our specialists' expertise for energy-efficient operation
- Safety guarantee with CE certification
- Reliable, durable operation and hassle-free maintenance during operating times due to units that can be deactivated individually
- Independent unit response to alarm messages with alarm notification via e-mail
- Local contact for guaranteed close cooperation and immediate assistance at all times
- One contact person for the entire system



# RoofVent® supply and extract air handling units

## Ventilation, heating and cooling of high spaces with energy recovery.

There is more than 45 years of climate technology experience in the new RoofVent® generation. This experience has allowed us to see what an environmentally compatible and easy-to-use indoor climate system looks like. The units in the RoofVent® product range control the supply of fresh air and the removal of extract air through the roof – all while guaranteeing maximum energy efficiency. This economical and ecological indoor climate solution is perfect for use in combination with heat pumps.

### RoofVent® supply and extract air handling units – it doesn't get more efficient than this

- Huge amount of flexibility and customised applications due to diverse product variants with optional equipment
- Heat recovery rate of up to 86% with the Hoval high-performance plate heat exchanger
- Suitable for combination with reversible heat pumps with a heating and cooling capacity of up to 67 kilowatts
- Reduced investment costs, as an equipment room and water supply network are not required
- Easily extendable with additional units
- Connection point for the entire electrical system on the below-roof unit – the electrical supply for the roof unit is integrated and tested at the factory
- Hoval HK-Select planning tool with all technical data for the quick and easy design of the RoofVent® units
- Efficient air distribution with the integrated Air-Injector – reduced heat loss and no pressure drops in ducts

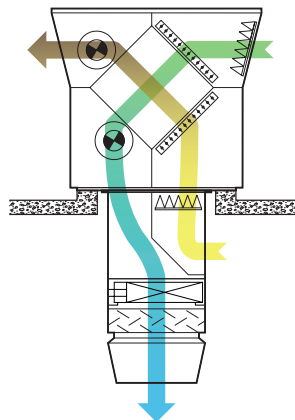

Technical data	
Air flow rate	m <sup>3</sup> /h
Heat output	kW
Cooling capacity (total)	kW
Operating distance	m x m
Weight	kg



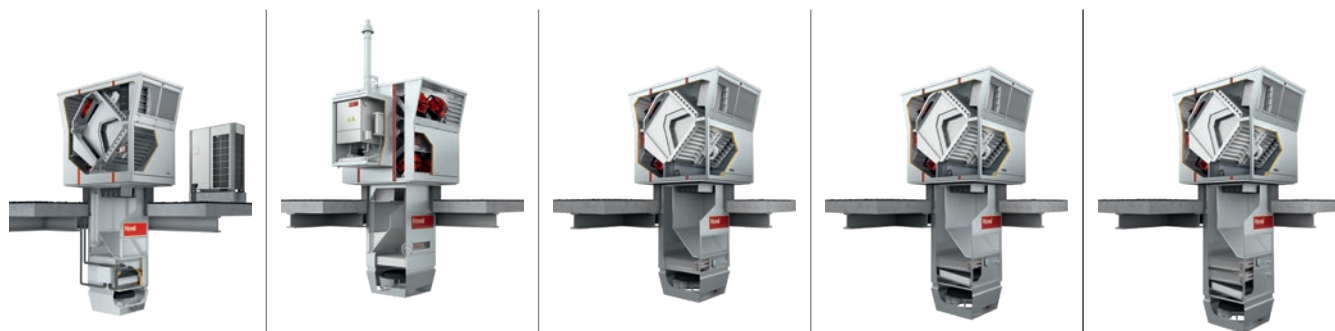

**Supply and extract air handling units with efficient air distribution**

<b>RoofVent® RP</b> Heating and cooling with decentralised heat pump		<b>RoofVent® RG</b> Heating with gas-fired heat generation	<b>RoofVent® RH</b> Heating with central heat generation		<b>RoofVent® RC</b> Heating and cooling with central heat and cold generation in the 2-pipe system		<b>RoofVent® RHC</b> Heating and cooling with central heat and cold generation in the 4-pipe system	
<b>Ventilation</b> <ul style="list-style-type: none"> <li>■ Fresh air supply</li> <li>■ Extract air removal</li> <li>■ Filters fresh air, recirculated air and extract air</li> <li>■ Air distribution with Air-Injector</li> <li>■ Recirculation operation</li> </ul>		<b>Ventilation</b> <ul style="list-style-type: none"> <li>■ Fresh air supply</li> <li>■ Extract air removal</li> <li>■ Filters fresh air, recirculated air and extract air</li> <li>■ Air distribution with Air-Injector</li> <li>■ Recirculation operation</li> </ul>	<b>Ventilation</b> <ul style="list-style-type: none"> <li>■ Fresh air supply</li> <li>■ Extract air removal</li> <li>■ Filters fresh air, recirculated air and extract air</li> <li>■ Air distribution with Air-Injector</li> <li>■ Recirculation operation</li> </ul>		<b>Ventilation</b> <ul style="list-style-type: none"> <li>■ Fresh air supply</li> <li>■ Extract air removal</li> <li>■ Filters fresh air, recirculated air and extract air</li> <li>■ Air distribution with Air-Injector</li> <li>■ Recirculation operation</li> </ul>		<b>Ventilation</b> <ul style="list-style-type: none"> <li>■ Fresh air supply</li> <li>■ Extract air removal</li> <li>■ Filters fresh air, recirculated air and extract air</li> <li>■ Air distribution with Air-Injector</li> <li>■ Recirculation operation</li> </ul>	
<b>Heating</b> <ul style="list-style-type: none"> <li>■ With heat pump</li> </ul>		<b>Heating</b> <ul style="list-style-type: none"> <li>■ With condensing gas boiler</li> </ul>	<b>Heating</b> <ul style="list-style-type: none"> <li>■ With connection to boiler system</li> </ul>		<b>Heating</b> <ul style="list-style-type: none"> <li>■ With connection to boiler system</li> </ul>		<b>Heating</b> <ul style="list-style-type: none"> <li>■ With connection to boiler system</li> </ul>	
<b>Cooling</b> <ul style="list-style-type: none"> <li>■ Free cooling</li> <li>■ With heat pump</li> </ul>		<b>Cooling</b> <ul style="list-style-type: none"> <li>■ Free cooling</li> </ul>	<b>Cooling</b> <ul style="list-style-type: none"> <li>■ Free cooling</li> </ul>		<b>Cooling</b> <ul style="list-style-type: none"> <li>■ Free cooling</li> <li>■ With connection to water chiller</li> </ul>		<b>Cooling</b> <ul style="list-style-type: none"> <li>■ Free cooling</li> <li>■ With connection to water chiller</li> </ul>	
Energy recovery		Energy recovery	Energy recovery		Energy recovery		Energy recovery	
<b>RP-6</b>	<b>RP-9</b>	<b>RG-9</b>	<b>RH-6</b>	<b>RH-9</b>	<b>RC-6</b>	<b>RC-9</b>	<b>RHC-6</b>	<b>RHC-9</b>
5500	8000	8000	5500	8000	5500	8000	5500	8000
upto 44	upto 44/76	upto 70	upto 78	upto 139	upto 78	upto 139	upto 78	upto 139
upto 44	upto 44/76	–	–	–	upto 52	upto 98	upto 52	upto 98
22 x 22	28 x 28	28 x 28	22 x 22	28 x 28	22 x 22	28 x 28	22 x 22	28 x 28
911	1200	1251	849	1104	882	1171	919	1244

# TopVent® recirculation and supply air units

Cost-effective solution for heating and cooling high spaces with supply air, recirculation or mixed air.

From large halls and high spaces to high-bay warehouses and supermarkets, the extensive model range in the TopVent® supply air and recirculation unit series caters to even the most diverse requirements and individual comfort expectations. The combination of decentralised and central heat and cold generation and the decentralised ventilation unit guarantees maximum sustainability in both the medium and long term.

Supply air and recirculation units in different output levels guarantee efficient air distribution via the patented Air-Injector vortex air distributor. Depending on the difference in temperature between the hall air and the air being blown in, the Air-Injector continuously and automatically adjusts the blowing angle and ensures an optimum flow stability.



## The future of indoor climate systems: cost efficient, flexible and environmentally friendly

- Maximum flexibility for all types of halls and hall usages with its modular and scalable system building block design with controller TopTronic® C (heat generation, recirculation air heating and cooling and zone-based control)
- Cost-effective supplement to the RoofVent® supply and extract air handling systems if there is a temporary increase in demand for heat or cooling capacity
- Air duct-free systems for easy assembly and low energy consumption
- Different coil types and accessories for tailor-made solutions
- Air curtains of different sizes and designs to protect entrance areas against the cold
- Control of up to ten units with the EasyTronic EC controller
- All supply air units can easily be adapted for operation with recirculated or mixed air
- All supply air units are available in two sizes, each fitted with a continuously adjustable fan and heating/cooling coil in different output levels for tailor-made solutions
- Hoval HK-Select planning tool with all technical data for the quick and easy design of the TopVent® units
- Efficient air distribution with the integrated Air-Injector – reduced heat loss and no pressure drops in ducts

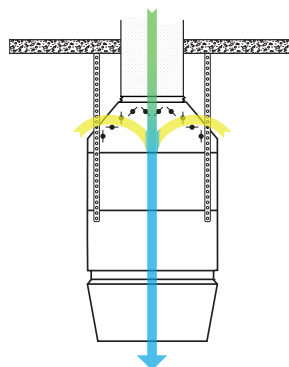

Technical data	
Air flow rate	m³/h
Heat output	kW
Cooling capacity (total)	kW
Operating distance	m x m
Weight	kg

## TopVent® recirculation units



### Recirculation units with efficient air distribution

TopVent® TP Heating and cooling with decentralised heat pump		TopVent® TH Heating with central heat generation		TopVent® TC Heating and cooling with central heat and cold generation in the 2-pipe system		TopVent® THC Heating and cooling with central heat and cold generation in the 4-pipe system	
<b>Ventilation</b> <ul style="list-style-type: none"> <li>■ Recirculation operation</li> <li>■ Air distribution with Air-Injector</li> <li>■ Air filtration (option)</li> </ul>		<ul style="list-style-type: none"> <li>■ Ventilation</li> <li>■ Recirculation operation</li> <li>■ Air distribution with Air-Injector</li> <li>■ Outlet nozzle (option)</li> <li>■ Air filtration (option)</li> </ul>		<b>Ventilation</b> <ul style="list-style-type: none"> <li>■ Recirculation operation</li> <li>■ Air distribution with Air-Injector</li> <li>■ Air filtration (option)</li> </ul>		<b>Ventilation</b> <ul style="list-style-type: none"> <li>■ Recirculation operation</li> <li>■ Air distribution with Air-Injector</li> <li>■ Air filtration (option)</li> </ul>	
<b>Heating</b> <ul style="list-style-type: none"> <li>■ With heat pump</li> </ul>		<b>Heating</b> <ul style="list-style-type: none"> <li>■ With connection to boiler system</li> </ul>		<b>Heating</b> <ul style="list-style-type: none"> <li>■ With connection to boiler system</li> </ul>		<b>Heating</b> <ul style="list-style-type: none"> <li>■ With connection to boiler system</li> </ul>	
<b>Cooling</b> <ul style="list-style-type: none"> <li>■ With heat pump</li> </ul>				<b>Cooling</b> <ul style="list-style-type: none"> <li>■ With connection to water chiller</li> </ul>		<b>Cooling</b> <ul style="list-style-type: none"> <li>■ With connection to water chiller</li> </ul>	
<b>TP-6</b>	<b>TP-9</b>	<b>TH-6</b>	<b>TH-9</b>	<b>TC-6</b>	<b>TC-9</b>	<b>THC-6</b>	<b>THC-9</b>
6000	9000	6000	9000	6000	9000	6000	9000
upto 44	upto 44/76	upto 76	upto 118	upto 76	upto 141	upto 76	upto 118
upto 44	upto 44/76	–	–	upto 44	upto 87	upto 44	upto 87
23 x 23	30 x 30	23 x 23	30 x 30	23 x 23	30 x 30	23 x 23	30 x 30
245	316	111	166	216	276	269	340

## TopVent® recirculation units



### Recirculation units

**TopVent® TW pro**  
Air curtain  
with central heat generation

**TopVent® TV**  
Heating  
with central heat generation

**Ventilation**

- Recirculation operation
- Air distribution via outlet grid

**Ventilation**

- Recirculation operation
- Air distribution via air outlet louvre

**Heating**

- With connection to boiler system
- TW Pro 150-1
- TW Pro 150-2
- TW Pro 200-1
- TW Pro 200-2

**Heating**

- With connection to boiler system

Technical data		150-0	200-0	150-1	200-1	150-2	200-2	TV-2	TV-4	TV-5
Air flow rate	m³/h	8500	12800	7900	11900	7300	10700	2100	4850	5700
Heat output	kW	–	–	up to 32	up to 48	up to 58	up to 88	up to 13	up to 30	up to 45
Cooling capacity (total)	kW	–	–	–	–	–	–	–	–	–
Operating distance	m x m	8.0	8.0	7.5	7.5	7.0	7.0	7 x 7	10 x 10	12 x 12
Weight	kg	43	58	51	66	54	70	16	23	24

## TopVent® supply air units

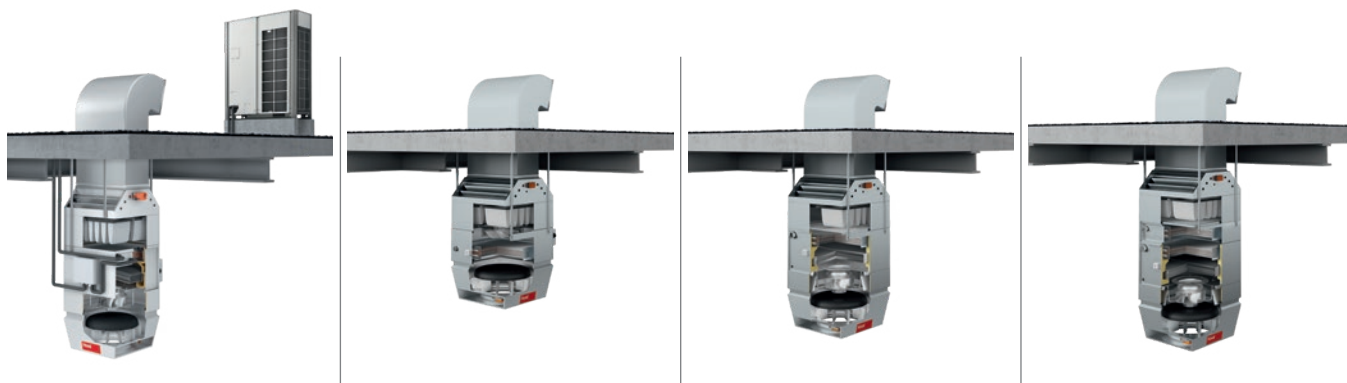

Supply air units with efficient air distribution							
<b>TopVent® MP</b> Heating and cooling with decentralised heat pump		<b>TopVent® MH</b> Heating with central heat generation		<b>TopVent® MC</b> Heating and cooling with central heat and cold generation in the 2-pipe system		<b>TopVent® MHC</b> Heating and cooling with central heat and cold generation in the 4-pipe system	
<b>Ventilation</b> <ul style="list-style-type: none"> <li>■ Fresh air supply (duct connection)</li> <li>■ Mixed air operation</li> <li>■ Recirculation operation</li> <li>■ Air distribution with Air-Injector</li> <li>■ Air filtration</li> </ul>		<b>Ventilation</b> <ul style="list-style-type: none"> <li>■ Fresh air supply (duct connection)</li> <li>■ Mixed air operation</li> <li>■ Recirculation operation</li> <li>■ Air distribution with Air-Injector</li> <li>■ Air filtration</li> </ul>		<b>Ventilation</b> <ul style="list-style-type: none"> <li>■ Fresh air supply (duct connection)</li> <li>■ Mixed air operation</li> <li>■ Recirculation operation</li> <li>■ Air distribution with Air-Injector</li> <li>■ Air filtration</li> </ul>		<b>Ventilation</b> <ul style="list-style-type: none"> <li>■ Fresh air supply (duct connection)</li> <li>■ Mixed air operation</li> <li>■ Recirculation operation</li> <li>■ Air distribution with Air-Injector</li> <li>■ Air filtration</li> </ul>	
<b>Heating</b> <ul style="list-style-type: none"> <li>■ With heat pump</li> </ul>		<b>Heating</b> <ul style="list-style-type: none"> <li>■ With connection to boiler system</li> </ul>		<b>Heating</b> <ul style="list-style-type: none"> <li>■ With connection to boiler system</li> </ul>		<b>Heating</b> <ul style="list-style-type: none"> <li>■ With connection to boiler system</li> </ul>	
<b>Cooling</b> <ul style="list-style-type: none"> <li>■ With heat pump</li> </ul>		<b>Cooling</b> <ul style="list-style-type: none"> <li>■ Free cooling</li> </ul>		<b>Cooling</b> <ul style="list-style-type: none"> <li>■ Free cooling</li> <li>■ With connection to water chiller</li> </ul>		<b>Cooling</b> <ul style="list-style-type: none"> <li>■ Free cooling</li> <li>■ With connection to water chiller</li> </ul>	
<b>MP-6</b>	<b>MP-9</b>	<b>MH-6</b>	<b>MH-9</b>	<b>MC-6</b>	<b>MC-9</b>	<b>MHC-6</b>	<b>MHC-9</b>
6000	9000	6000	9000	6000	9000	6000	9000
up to 44	up to 44/76	up to 78	up to 121	up to 78	up to 145	up to 78	up to 121
up to 44	up to 44/76	–	–	up to 34	up to 68	up to 34	up to 68
23 x 23	30 x 30	23 x 23	30 x 30	23 x 23	30 x 30	23 x 23	30 x 30
304	380	172	228	266	334	305	399

## TopVent® roof units

The TopVent® roof ventilation units have been specially developed for the requirements of modern logistics, production or industrial halls.

- Maintenance access from the outside
- Optimum climate
- Economical

These units are mainly used where **undisturbed hall operation** at a constant temperature is required. Service, maintenance and even installation are performed from the roof, so operation can continue in the hall without any disruption.

4 recirculation and supply air units in each case, with various output levels, guarantee efficient air distribution via the patented Air-Injector vortex air distributor.

Heating and cooling is possible using a central supply or with a decentralised heat pump (TopVent® SH optionally also available with adiabatic cooling).

### For undisturbed hall operation.

- Maintenance work can be performed from the roof, meaning that work in the hall is not restricted.
- Little space is required in the hall – there just needs to be enough room for air distribution.
- Hoval HK-Select planning tool with all technical data for the quick and easy design of the TopVent® units
- Efficient air distribution with the integrated Air-Injector – lower heat losses and no duct pressure losses

## TopVent® roof recirculation units

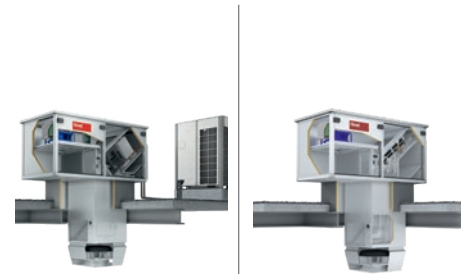

### Roof recirculation units

- |  |   |
|--|---|
| <p><b>TopVent® CP</b><br/>Heating and cooling with decentralised heat pump</p> | <p><b>TopVent® CH</b><br/>Heating with central heat generation in the 2-pipe system</p> |
|--|---|

- |   |   |
|---|---|
| <p><b>Ventilation</b></p> <ul style="list-style-type: none"> <li>■ Recirculation operation</li> <li>■ Air distribution with Air-Injector</li> <li>■ Air filtration</li> </ul> | <p><b>Ventilation</b></p> <ul style="list-style-type: none"> <li>■ Recirculation operation</li> <li>■ Air distribution with Air-Injector</li> <li>■ Outlet nozzle (Option)</li> <li>■ Air filtration</li> </ul> |
|---|---|

- |  |  |
|--|--|
| <p><b>Heating</b></p> <ul style="list-style-type: none"> <li>■ With heat pump</li> </ul> | <p><b>Heating</b></p> <ul style="list-style-type: none"> <li>■ With connection to boiler system</li> </ul> |
|--|--|

- Cooling**
- With heat pump

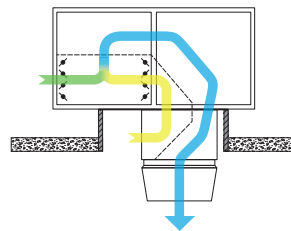

Technical data		CP-6	CP-9	CH-6	CH-9
Air flow rate	m³/h	6000	9000	6000	9000
Heat output	kW	up to 44	up to 44/76	up to 76	up to 118
Cooling capacity (total) kW		up to 44	up to 44/76	–	–
Operating distance	m x m	23 x 23	31 x 31	23 x 23	31 x 31
Weight	kg	672	869	616	719

## TopVent® roof supply air units

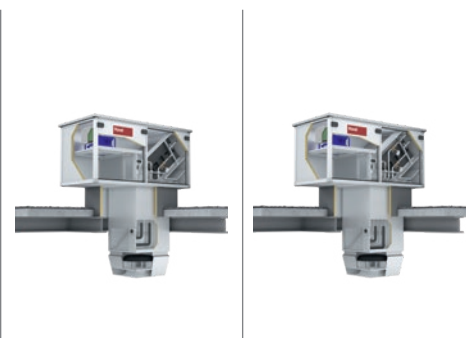

**with efficient air distribution**

<b>TopVent® CC</b> Heating and cooling with central heat and cold generation in the 2-pipe system		<b>TopVent® CHC</b> Heating and cooling with central heat and cold generation in the 4-pipe system	
<b>Ventilation</b> <ul style="list-style-type: none"> <li>Recirculation operation</li> <li>Air distribution with Air-Injector</li> <li>Air filtration</li> </ul>		<b>Ventilation</b> <ul style="list-style-type: none"> <li>Recirculation operation</li> <li>Air distribution with Air-Injector</li> <li>Air filtration</li> </ul>	
<b>Heating</b> <ul style="list-style-type: none"> <li>With connection to boiler system</li> </ul>		<b>Heating</b> <ul style="list-style-type: none"> <li>With connection to boiler system</li> </ul>	
<b>Cooling</b> <ul style="list-style-type: none"> <li>With connection to water chiller</li> </ul>		<b>Cooling</b> <ul style="list-style-type: none"> <li>With connection to water chiller</li> </ul>	
<b>CC-6</b>	<b>CC-9</b>	<b>CHC-6</b>	<b>CHC-9</b>
6000	9000	6000	9000
up to 76	up to 141	up to 76	up to 118
up to 44	up to 87	up to 44	up to 87
23 x 23	31 x 31	23 x 23	31 x 31
647	843	684	898

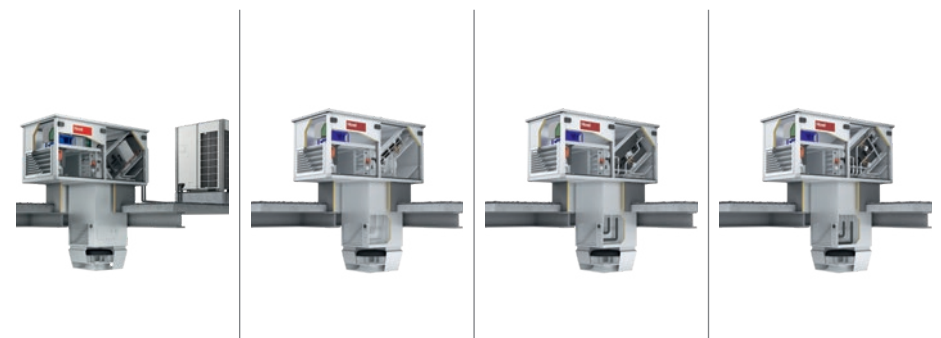

**Roof supply air units with efficient air distribution**

<b>TopVent® SP</b> Heating and cooling with decentralised heat pump		<b>TopVent® SH</b> Heating with central heat generation in the 2-pipe system		<b>TopVent® SC</b> Heating and cooling with central heat and cold generation in the 2-pipe system		<b>TopVent® SHC</b> Heating and cooling with central heat and cold generation in the 4-pipe system	
<b>Ventilation</b> <ul style="list-style-type: none"> <li>Recirculation operation</li> <li>Supply air operating mode</li> <li>Air distribution with Air-Injector</li> <li>Air filtration</li> </ul>		<b>Ventilation</b> <ul style="list-style-type: none"> <li>Recirculation operation</li> <li>Supply air operating mode</li> <li>Air distribution with Air-Injector</li> <li>Outlet nozzle (Option)</li> <li>Air filtration</li> </ul>		<b>Ventilation</b> <ul style="list-style-type: none"> <li>Recirculation operation</li> <li>Supply air operating mode</li> <li>Air distribution with Air-Injector</li> <li>Air filtration</li> </ul>		<b>Ventilation</b> <ul style="list-style-type: none"> <li>Recirculation operation</li> <li>Supply operating air mode</li> <li>Air distribution with Air-Injector</li> <li>Air filtration</li> </ul>	
<b>Heating</b> <ul style="list-style-type: none"> <li>With heat pump</li> </ul>		<b>Heating</b> <ul style="list-style-type: none"> <li>With connection to boiler system</li> </ul>		<b>Heating</b> <ul style="list-style-type: none"> <li>With connection to boiler system</li> </ul>		<b>Heating</b> <ul style="list-style-type: none"> <li>With connection to boiler system</li> </ul>	
<b>Cooling</b> <ul style="list-style-type: none"> <li>Free cooling</li> <li>With heat pump</li> </ul>		<b>Cooling</b> <ul style="list-style-type: none"> <li>Free cooling</li> <li>adiabatic cooling (Option)</li> </ul>		<b>Cooling</b> <ul style="list-style-type: none"> <li>Free cooling</li> <li>With connection to water chiller</li> </ul>		<b>Cooling</b> <ul style="list-style-type: none"> <li>Free cooling</li> <li>With connection to water chiller</li> </ul>	
<b>SP-6</b>	<b>SP-9</b>	<b>SH-6</b>	<b>SH-9</b>	<b>SC-6</b>	<b>SC-9</b>	<b>SHC-6</b>	<b>SHC-9</b>
6000	9000	6000	9000	6000	9000	6000	9000
up to 44	up to 44/76	up to 78	up to 121	up to 78	up to 145	up to 78	up to 121
up to 44	up to 44/76	–	–	up to 34	up to 68	up to 34	up to 68
23 x 23	31 x 31	23 x 23	31 x 31	23 x 23	31 x 31	23 x 23	31 x 31
717	924	661	846	692	898	729	953

## TopVent® gas-fired recirculation and supply air units:

In TopVent® gas units, heat is generated via a decentralised, gas-fired heat exchanger. The modulating premix burners used keep emissions to a minimum, guaranteeing cost effectiveness and environmental efficiency. The systems are delivered ready to install with a suspension set and exhaust accessories.

### Generates heat exactly where it is needed – superior technology for decentralised heating

- Heat is generated exactly where it is needed and is guided directly into the hall without any losses. No pipes or heat loss from the heat generator to the heat consumer
- Reduced investment and running costs, as a boiler room, fuel storage room and hot water supply network are not required for the gas-fired system
- Room air-independent supply – supply air is injected from outside
- Broad model range permits planning to size – precisely attuned to the room circumstances and specific requirements
- TempTronic MTC – cost-effective basic controller for up to 8 TopVent GV units
- Air distribution is continuously adjusted with the integrated Air-Injector

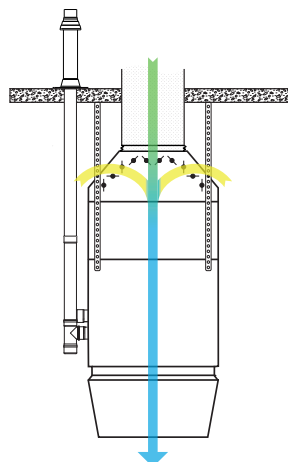
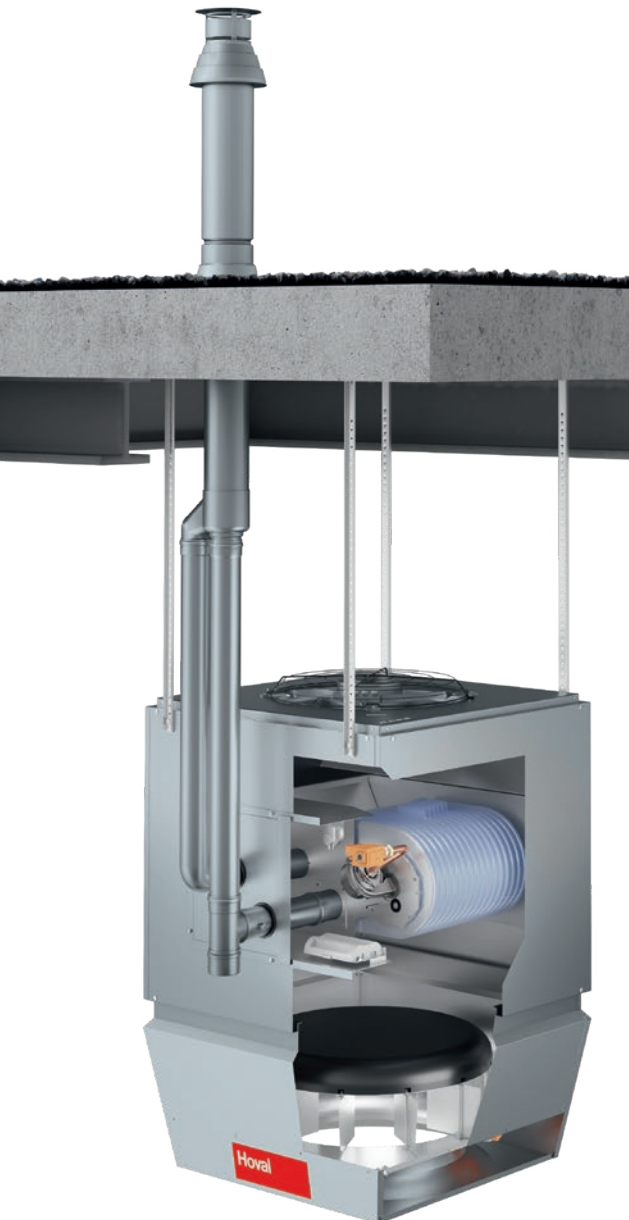

Technical data	
Air flow rate	m <sup>3</sup> /h
Heat output	kW
Operating distance	m x m
Weight	kg



TopVent® gas-fired recirculation and supply air units:

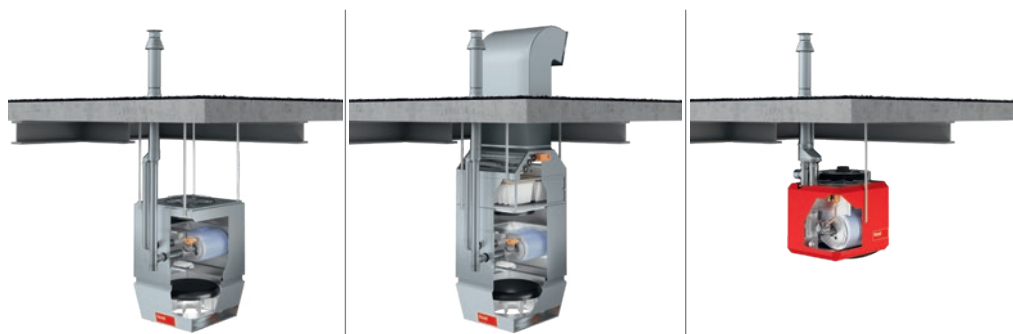

Gas-fired recirculation and supply air units with efficient air distribution					
<b>TopVent® TG</b> Recirculation unit with efficient air distribution		<b>TopVent® MG</b> Supply air unit with efficient air distribution		<b>TopVent® GV</b> Recirculation unit	
<b>Ventilation</b> <ul style="list-style-type: none"> <li>■ Recirculation operation</li> <li>■ Air distribution with Air-Injector</li> <li>■ Air filtration (option)</li> <li>■ Outlet nozzle (option)</li> </ul>		<b>Ventilation</b> <ul style="list-style-type: none"> <li>■ Fresh air supply (duct connection)</li> <li>■ Mixed air operation</li> <li>■ Recirculation operation</li> <li>■ Air distribution with Air-Injector</li> <li>■ Air filtration</li> </ul>		<b>Ventilation</b> <ul style="list-style-type: none"> <li>■ Recirculation operation</li> <li>■ Air distribution via air outlet louvre</li> </ul>	
<b>Heating</b> <ul style="list-style-type: none"> <li>■ With gas-fired heat exchanger</li> </ul>		<b>Heating</b> <ul style="list-style-type: none"> <li>■ With gas-fired heat exchanger</li> </ul>		<b>Heating</b> <ul style="list-style-type: none"> <li>■ With gas-fired heat exchanger</li> </ul>	
<b>TG-6</b>	<b>TG-9</b>	<b>MG-6</b>	<b>MG-9</b>	<b>GV-3</b>	<b>GV-5</b>
7000	11000	7000	11000	4200	8500
30	60	30	60	30	50
28 x 28	31 x 31	28 x 28	31 x 31	12 x 12	16 x 16
125	170	175	230	40	80

## ProcessVent compact units

Ventilation, heating and cooling of production halls with highly efficient energy recovery from process air.

ProcessVent units in combination with an extract air purification plant form a single efficient universal system with outstanding emission levels and heating cost savings of up to 98%. The compact units are deployed in halls with enclosed machine tools or welding plants and are positioned right next to machine groups.

### Clear the air and benefit from a healthy indoor climate and reduced operating costs

- Energy recovery from (clean) process air via an oil-tight plate heat exchanger ensures significantly reduced heat energy costs.
- Ecological! Even vapours which are not captured by the extract air purification plant condense in the oil-tight plate heat exchanger of the ProcessVent units. Cutting fluid can therefore be recovered or disposed of in an environmentally responsible manner.
- Choice of a heating/cooling coil for supplemental heating or cooling of the fresh air, or in recirculation operation
- ProcessVent units use the integrated control to work both in conjunction with the extract air purification plant or autonomously. This means that each unit can be tailored to each operating condition.
- Complies with the legal requirements for energy-efficient, environmentally friendly production methods and healthy working conditions
- Possibility of an investment subsidy through relevant subsidy programmes, including subsidies for cross-sectional technologies or energy recovery and waste heat utilisation measures

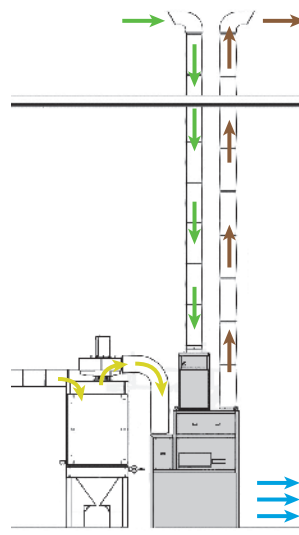
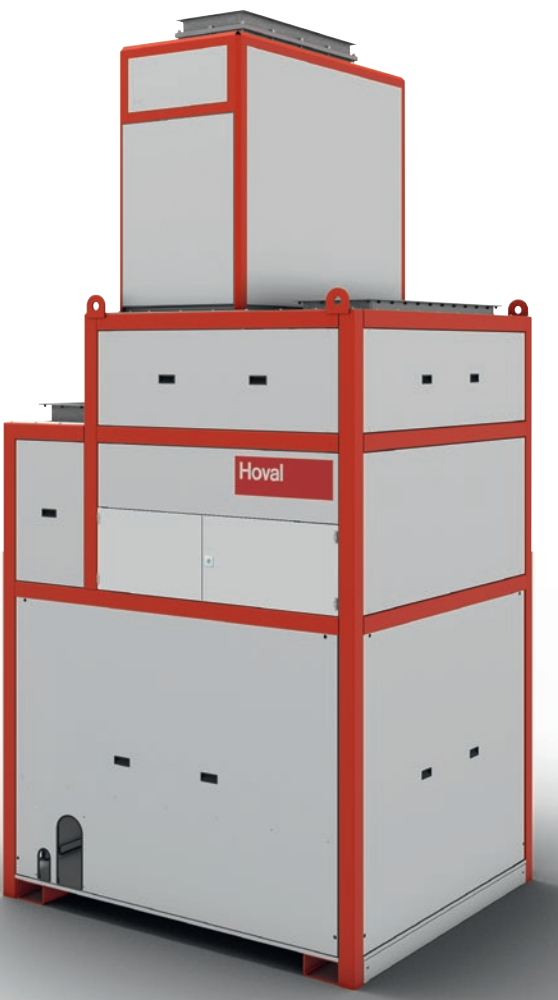

Technical data	
Air flow rate	m <sup>3</sup> /h
Heat output	kW
Cooling capacity (total)	kW
Operating distance	m x m
Weight	kg



**Compact units with energy recovery from process air**

<p><b>ProcessVent PV</b> Compact unit for ventilating with energy recovery from process air</p>	<p><b>ProcessVent PVH</b> Compact unit for ventilating and heating with energy recovery from process air</p>	<p><b>ProcessVent PVC</b> Compact unit for ventilating, heating and cooling with energy recovery from process air</p>
<p><b>Ventilation</b></p> <ul style="list-style-type: none"> <li>■ Fresh air supply</li> <li>■ Extract air removal (air conveyance via the extract air purification plant)</li> <li>■ Recirculation operation</li> <li>■ Air filtration</li> </ul>	<p><b>Ventilation</b></p> <ul style="list-style-type: none"> <li>■ Fresh air supply</li> <li>■ Extract air removal (air conveyance via the extract air purification plant)</li> <li>■ Recirculation operation</li> <li>■ Air filtration</li> </ul>	<p><b>Ventilation</b></p> <ul style="list-style-type: none"> <li>■ Fresh air supply</li> <li>■ Extract air removal (air conveyance via the extract air purification plant)</li> <li>■ Recirculation operation</li> <li>■ Air filtration</li> </ul>
	<p><b>Heating</b></p> <ul style="list-style-type: none"> <li>■ With connection to boiler system</li> </ul>	<p><b>Heating</b></p> <ul style="list-style-type: none"> <li>■ With connection to boiler system</li> </ul>
		<p><b>Cooling</b></p> <ul style="list-style-type: none"> <li>■ With connection to water chiller</li> </ul>
<p><b>Energy recovery from process air</b></p>		
<p><b>PV-10</b></p>	<p><b>PVH-10</b></p>	<p><b>PVC-10</b></p>
<p>10000</p>	<p>10000</p>	<p>10000</p>
<p>–</p>	<p>up to 234</p>	<p>up to 256</p>
<p>–</p>	<p>–</p>	<p>up to 118</p>
<p>–</p>	<p>–</p>	<p>–</p>
<p>1657</p>	<p>1699</p>	<p>1754</p>

# Simply change the world

## Hoval references.

**Hoval's sophisticated air and climate solutions are ensuring the supply of healthy, fresh air and pleasant heat around the world – in distant China and high up on our own mountain peaks. Discover the world of Hoval's indoor climate systems.**

Join us on a journey across the globe and discover more about our technologically superior indoor climate systems::

- 
- In the “green building” at the Pannonian Wood Competence Center in Virovitica, Croatia
- At long-established tool, mould and fixture manufacturer Veith in Öhringen, Baden-Württemberg, Germany

### Fully decentralised solution at HÖRMANN Klatt Conveyors GmbH near Salzburg in Austria

The 4,600 m<sup>2</sup> building consists of a warehouse, a production hall, a final assembly hall and offices. Instead of using gas, the company now heats and cools with nine TopVentTP units and ten heat pumps. The expansion of the existing photovoltaic system provides sufficient green electricity.

In addition to powerful and efficient air distribution, the TopVent TP units are particularly easy to install.

- 9 TopVent® TP-6
- Hoval TopTronic® C control system for energy-efficient ventilation and heating



„The ventilation is barely perceptible,  
but the climatic conditions in the hall are  
always excellent.“

Nana Filipović  
Pannonian Wood Competence Center

### Competence centre housed in “green building”

The largest project to be backed by the European structural and investment funds to date, construction of the “green building” at the Pannonian Wood Competence Center in the Croatian city of Virovitica was completed in 2016. The innovation and development centre supports wood processing companies and was designed according to “green building” principles. Hoval’s decentralised indoor climate system serves to perfectly extend the centre’s sustainability in terms of heating and ventilation

- 2 RoofVent® RH
- 2 TopVent® TH



### Expansion of production at metal processing company Veith

Globally operational and steeped in tradition, Alfred Konrad Veith GmbH & Co. KG’s production operations are spread across two sites with a total of 200 employees and over 7,000 m² of production space. The company has stood for premium products for over 100 years, and Veith’s passion for quality and precision is equally reflected in its choice of ventilation and heating solution.

- 5 RoofVent® RH-9 units ventilate and heat the production hall for stamping parts and the tool shop
- Hoval TopTronic® C controls energy-efficient heating and ventilation
- Overnight cooling with fresh air preserves resources



## All good things come from above

Indoor climate systems in use.

Whatever your requirements, we will make sure that you get the very best air quality – in factory and production halls, logistics centres, airplane hangars, maintenance hangars, shipyards, shopping centres, building centres, sports facilities, swimming pools, trade fair halls, multi-purpose halls, car showrooms, and wherever else you need it.



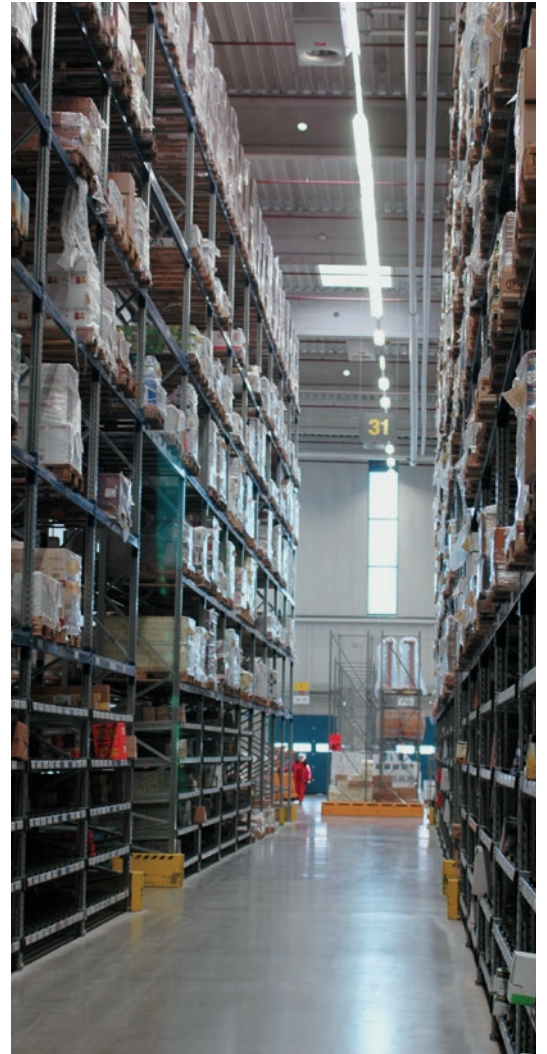

**Hoval quality.**  
You can count on us.

Hoval is one of the leading international companies for heating and indoor climate solutions. Drawing on more than 75 years of experience and benefiting from a close-knit team culture, the Hoval Group delivers exciting solutions and develops technically superior products. This leadership role requires a sense of responsibility for energy and the environment, which is expressed in an intelligent combination of different heating technologies and customised indoor climate solutions.

Hoval also provides personal consultations and comprehensive customer service. With around 2500 employees in 15 companies around the world, Hoval sees itself not as a conglomerate, but as a large family that thinks and acts globally.

Hoval heating and indoor climate solutions are currently exported to more than 50 countries.

## Responsibility for energy and environment

Your Hoval partner

### Liechtenstein

Hoval Aktiengesellschaft  
9490 Vaduz  
+423 399 24 00  
hoval.com

### United Kingdom

Hoval Ltd.  
Newark Notts. NG 24 1JN  
+44 1636 672 711  
hoval.co.uk