

Hoval TransTherm[®] aqua

Calorifier continuous flow system

TransTherm[®] aqua F (6-10)-(6-50)



Table of contents

■ Description	5
■ Part numbers	6
■ Technical data	10
■ Dimensions	17
■ Example	21

Calorifier continuous flow system

Consisting of:

- fresh water module TransTherm® aqua F
- buffer storage tank (option)

Fresh water module TransTherm® aqua F

- Fully installed station with plate heat exchanger for the provision of domestic hot water using the continuous flow principle
- Intended for wall installation
- The primary side (heating side) contains the three-way valve, high-efficiency pump, ventilation, filling/drain valve and balancing valve. These components ensure a constant flow temperature at the plate heat exchanger. Pipes made from steel
- The secondary side (DHW side) contains the safety valve (10 bar), non-return valve and a filling/drain valve. A flow sensor ensures the correct hot water temperature. Pipes made from stainless steel
- Stainless steel plate heat exchanger 1.4404, copper-soldered or copper-free
- EPP insulation, 30 mm, for the heat exchanger
- Flow sensor
- Switch-on and switch-off of the charging pump is regulated via two sensors (included in the scope of delivery) in the storage tank
- Mount tank sensor on the tank on site and connect it to the controller
- T-piece with dummy plug for on-site connection of the circulation group. Connect the pump to the controller on site.
- TopTronic® E control with integrated thermal disinfection of the DHW storage tank (anti-legionella circuit)



Range

Fresh water module

TransTherm® aqua F type	Output kW
(6-10)	50
(6-16)	90
(6-20)	115
(6-30)	175
(6-40)	230
(6-50)	275

Delivery

- The buffer storage tank required is not included in the scope of delivery

On site

- Installation of a circulation unit; the necessary connection is provided
- Electrical connection of the controller

TopTronic® E controller

TopTronic® E basic module district heating/fresh water

- Control unit for controlling district heating transfer stations in non-communicative networks and the corresponding consumers with integrated control functions for
 - primary valve control
 - cascade management
 - 1 heating/cooling circuit with mixer
 - 1 heating/cooling circuit without mixer
 - 1 hot water charging circuit
 - various additional functions
- Various functions for hot water:
 - selection of different basic programs (week programs, economy mode, holiday until, etc.)
 - various operating modes (e.g. accumulator priority or parallel mode)
 - buffer storage circuit on the primary or secondary side
 - adjustable loading criteria (e.g. adjustable loading times, undershooting the minimum nominal value, etc.)

- adjustable switch-off criteria (e.g. achieving the setpoint valve, achieving the lower sensor setpoint value, etc.)
- adjustable loading block (if the loading flow temperature is too low, the setpoint temperature is not reached, differential temperature-dependent solar circuit control)
- Definable switching times for recirculation pump control
- Outdoor sensor
- Immersion sensor (calorifier sensor)
- Contact sensor (flow temperature sensor)
- Complete plug set for DH module
- speed-controlled pumps

No further module expansions or controller modules can be installed in the control panel!

Option

TopTronic® E control module

- Simple, intuitive operating concept
- Display of the most important operating states
- Configurable start screen
- Operating mode selection
- Configurable day and week programs
- Operation of all connected Hoval CAN bus modules
- Commissioning wizard
- Service and maintenance function
- Fault message management
- Analysis function
- Weather display (with HovalConnect option)

- Adaptation of the heating strategy based on the weather forecast (with HovalConnect option)

Notice

The TopTronic® E control module for operating the basic module district heating/fresh water must be ordered separately!

Further information about the TopTronic® E see "Controls"

Delivery

- All armatures required for operation, such as flow balancing and shut-off valves, backflow preventer, air-bleeding and drain valve are fitted.

Caution

As a result of thermal disinfection of the domestic hot water for legionella protection, increased water temperatures (at least 65 ... 70 °C) occur. Depending on the water quality, this may result in increased calcification at the installed armatures and heat exchangers and also brings the risk of scalding at the tapping points. Corresponding protective measures must be implemented on site.

Hot water connection for application according to the SVGW (Swiss association for electricity, gas, district heating and water)
 The installation of ball valves is not permitted in Switzerland according to SVGW regulation W3.

Fresh water module



TransTherm® aqua F

Fully assembled station with plate heat exchanger for the provision of domestic hot water using the continuous flow principle and built-in Hoval TopTronic® E control
The required buffer storage tank is not supplied.

TransTherm® aqua F	Output kW
(6-10)	50
(6-16)	90
(6-20)	115
(6-30)	175
(6-40)	230
(6-50)	275

Authorisation number

TransTherm® aqua F (6-10)-(6-50)
SVGW test number 2407-7331

Version with copper-free heat exchanger

TransTherm® aqua F

with copper-free heat exchanger

TransTherm® aqua F	Output kW
(6-10)	50
(6-16)	90
(6-20)	115
(6-30)	175
(6-40)	230
(6-50)	275

Part No.

8006 387
8006 388
8006 389
8006 390
8006 391
8006 392
8006 521
8006 522
8006 523
8006 524
8006 525
8006 526

Accessories

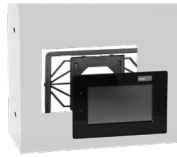

TopTronic® E control module black with 4.3" colour touchscreen

For operation of all controller modules connected to the bus system (basic, solar, buffer modules etc.)
 Connection to the Hoval bus system via RJ45 plug connection or via plug terminals (max. 0.75 mm²), flat design with flexible installation option

Installation:

- in control panel of the heat generator
- in the Hoval wall casing
- in the control panel front, black high-gloss cover, customer-specific configurable start screen,

Display of current weather or weather forecast (only possible in combination with HovalConnect)

Consisting of:

- TopTronic® E control module black
- Clamping device set control module
- RJ45-RAST 5 CAN cable, L = 500



Return changeover valve set

Consisting of:

- temperature sensor
- changeover valve
- drive (8 sec.) DN 20-40
- drive (30 sec.) DN 50-80
- seals
- screw connections

Nominal diameter	Output kW	k _{vs} m ³ /h
DN 20	50-90	6.3
DN 25	115-175	10
DN 32	230-275	16
DN 40	350	25
DN 50	450	40
DN 65	580	63
DN 80	700	100

6043 844

7010 832
 7010 836
 7011 009
 7011 025
 7016 331
 7016 332
 7016 333

Notice

When using a circulation set (also on-site recirculation pump), it is imperative to install a return switching valve set.



Circulation set

for TransTherm® aqua L, L-FW, F
 Piping of parts in contact with domestic water in stainless steel and gunmetal

Consisting of:

- temperature sensor PT1000
- recirculation pump Wilo Yonos PARA
- recirculation pump Wilo Para MAXO
- regulating valve
- non-return valve

Connection	Flow rate m ³ /h	Recirculation pump
DN 20 ¾" Rp	1.9	Z15/7.0 RKC
DN 25 1" Rp	3.4	Z25/180/08/F02
DN 32 1¼" Rp	5.8	Z25/180/08/F02

8005 279
 8005 280
 8005 281

Part No.



Test valve DN 8 G 1/4"
 for TransTherm® aqua L, L-FW, F, FS
 Test valve suitable for flame treatment
 for hygienic-microbiologic
 tests.

2049 861



Sludge separator DM with magnet
 made of technopolymer (PO) or
 brass with insulation (MS)

Type	Connection inches	Flow rate at 1.2 m/s flow speed m³/h	k _v value m³/h
DM PO	Rp 1"	1.3	10.5
DM PO	Rp 1 1/4"	2.1	10.5
DM MS	Rp 1 1/2"	5.4	63.2
DM MS	Rp 2"	8.2	70.0

2054 376
 2085 523
 2085 527
 2085 528

Additional sludge separators
 see "Various system components"







**Insulation for sludge separator
 DM PO 1"**
 10 mm insulating caps made of PE-X foam
 Thermal conductivity 0.035 W/mK
 Fire resistance (DIN 4102): class B2

2085 524



**Insulation for sludge separator
 DM PO 1 1/4"**
 10 mm insulating caps made of PE-X foam
 Thermal conductivity 0.035 W/mK
 Fire resistance (DIN 4102): class B2

2086 031

		Part No.
	Temperature monitor 0 ... 120 °C for TransTherm® aqua L, L-FW, F, FS	2048 299
	Safety temperature monitor 70 ... 130 °C for TransTherm® aqua L, L-FW, F, FS	2048 300
	Safety temperature limiter 70 ... 130 °C for TransTherm® aqua L, L-FW, F, FS	2049 619
	Immersion sleeve G 1/2" stainless steel for thermostat for TransTherm® aqua L, L-FW, F, FS Installation length = 100 mm Outer Ø: 8 mm, inner Ø: 6.5 mm	2048 285
	Immersion sleeve G 1/2" stainless steel for 2 thermostats for TransTherm® aqua L, L-FW, F, FS Installation length = 100 mm Outer Ø: 15 mm, inner Ø: 13.5 mm	2048 288

Services



Services and associated scope of services
see separate catalogue "Hoval Services"

Commissioning by Hoval customer service is a prerequisite for warranty/guarantee activation.

Performance data

TransTherm® aqua F (6-10 to 6-50)

Domestic water secondary		TransTherm® aqua F		Flow temperature heating water											
				55 °C (6-...)						60 °C (6-...)					
				(10)	(16)	(20)	(30)	(40)	(50)	(10)	(16)	(20)	(30)	(40)	(50)
60/5 °C	T return primary	°C		-	-	-	-	-	-	-	-	-	-	-	-
	Ṽ primary	m³/h		-	-	-	-	-	-	-	-	-	-	-	-
	Q max.	kW		-	-	-	-	-	-	-	-	-	-	-	-
	Ṽ secondary	m³/h		-	-	-	-	-	-	-	-	-	-	-	-
60/10 °C	T return primary	°C		-	-	-	-	-	-	-	-	-	-	-	-
	Ṽ primary	m³/h		-	-	-	-	-	-	-	-	-	-	-	-
	Q max.	kW		-	-	-	-	-	-	-	-	-	-	-	-
	Ṽ secondary	m³/h		-	-	-	-	-	-	-	-	-	-	-	-
60/15 °C	T return primary	°C		-	-	-	-	-	-	-	-	-	-	-	-
	Ṽ primary	m³/h		-	-	-	-	-	-	-	-	-	-	-	-
	Q max.	kW		-	-	-	-	-	-	-	-	-	-	-	-
	Ṽ secondary	m³/h		-	-	-	-	-	-	-	-	-	-	-	-
60/20 °C	T return primary	°C		-	-	-	-	-	-	-	-	-	-	-	-
	Ṽ primary	m³/h		-	-	-	-	-	-	-	-	-	-	-	-
	Q max.	kW		-	-	-	-	-	-	-	-	-	-	-	-
	Ṽ secondary	m³/h		-	-	-	-	-	-	-	-	-	-	-	-
55/5 °C	T return primary	°C		-	-	-	-	-	-	30	30	30	30	30	30
	Ṽ primary	m³/h		-	-	-	-	-	-	1.25	2.04	2.51	3.71	4.76	5.66
	Q max.	kW		-	-	-	-	-	-	43	70	86	127	163	194
	Ṽ secondary	m³/h		-	-	-	-	-	-	0.74	1.2	1.48	2.18	2.8	3.33
55/10 °C	T return primary	°C		-	-	-	-	-	-	30	30	30	30	30	30
	Ṽ primary	m³/h		-	-	-	-	-	-	1.11	2.04	2.51	3.71	4.76	5.63
	Q max.	kW		-	-	-	-	-	-	38	70	86	127	163	193
	Ṽ secondary	m³/h		-	-	-	-	-	-	0.73	1.34	1.64	2.43	3.12	3.69
55/15 °C	T return primary	°C		-	-	-	-	-	-	30	30	30	30	30	30
	Ṽ primary	m³/h		-	-	-	-	-	-	0.76	1.46	1.95	3.06	4.23	5.4
	Q max.	kW		-	-	-	-	-	-	26	50	67	105	145	185
	Ṽ secondary	m³/h		-	-	-	-	-	-	0.56	1.08	1.44	2.26	3.12	3.98
55/20 °C	T return primary	°C		-	-	-	-	-	-	30	30	30	30	30	30
	Ṽ primary	m³/h		-	-	-	-	-	-	0.47	0.9	1.17	1.9	2.63	3.36
	Q max.	kW		-	-	-	-	-	-	16	31	40	65	90	115
	Ṽ secondary	m³/h		-	-	-	-	-	-	0.39	0.76	0.99	1.6	2.22	2.83
50/5 °C	T return primary	°C		30	30	30	30	30	30	30	30	30	30	30	30
	Ṽ primary	m³/h		1.29	2.03	2.51	3.67	4.72	5.66	1.28	2.04	2.51	3.71	4.76	5.63
	Q max.	kW		37	58	72	105	135	162	44	70	86	127	163	193
	Ṽ secondary	m³/h		0.71	1.11	1.37	2	2.58	3.09	0.84	1.34	1.64	2.43	3.12	3.69
50/10 °C	T return primary	°C		30	30	30	30	30	30	30	30	30	30	30	30
	Ṽ primary	m³/h		1.29	2.03	2.51	3.67	4.72	5.66	1.28	2.04	2.51	3.73	4.81	5.69
	Q max.	kW		38	58	72	105	135	162	44	70	86	128	165	195
	Ṽ secondary	m³/h		0.82	1.25	1.77	2.26	2.9	3.48	0.95	1.51	1.85	2.75	3.55	4.19
50/15 °C	T return primary	°C		30	30	30	30	30	30	30	30	30	30	30	30
	Ṽ primary	m³/h		1.29	2.03	2.51	3.67	4.72	5.66	1.11	1.95	2.48	3.76	4.76	5.69
	Q max.	kW		37	58	72	105	135	162	38	67	85	129	163	195
	Ṽ secondary	m³/h		0.91	1.43	1.77	2.58	3.32	3.99	0.94	1.65	2.09	3.18	4.01	4.8
50/20 °C	T return primary	°C		30	30	30	30	30	30	30	30	30	30	30	30
	Ṽ primary	m³/h		1.15	2.03	2.55	3.7	4.75	5.69	0.96	1.69	2.13	3.24	3.63	5.16
	Q max.	kW		33	58	73	106	136	163	33	58	73	111	145	177
	Ṽ secondary	m³/h		0.95	1.67	2.1	3.05	3.91	4.69	0.95	1.67	2.1	3.19	4.17	5.09
45/5 °C	T return primary	°C		19	18	18	18	18	17	17	16	16	16	16	15
	Ṽ primary	m³/h		0.86	1.91	2.9	2.9	3.8	4.61	0.86	1.92	2.91	2.91	3.82	4.63
	Q max.	kW		35	80	123	123	162	199	42	95	145	145	192	235
	Ṽ secondary	m³/h		0.76	1.73	2.65	2.65	3.50	4.27	0.90	2.05	3.13	3.13	4.14	5.05
45/10 °C	T return primary	°C		21	21	20	20	20	20	20	19	19	19	18	18
	Ṽ primary	m³/h		0.86	1.91	2.89	2.89	3.81	4.62	0.86	1.92	2.84	2.84	3.63	4.32
	Q max.	kW		33	74	114	114	151	185	39	89	133	133	172	207
	Ṽ secondary	m³/h		0.81	1.84	2.81	2.81	3.74	4.56	0.97	2.20	3.29	3.29	4.25	5.09
45/15 °C	T return primary	°C		24	23	23	23	23	23	23	22	21	21	21	21
	Ṽ primary	m³/h		0.86	1.91	2.91	2.91	3.81	4.62	0.87	1.8	2.61	2.61	3.33	3.98
	Q max.	kW		30	69	106	106	139	170	37	78	115	115	148	178
	Ṽ secondary	m³/h		0.88	1.99	3.05	3.05	4.02	4.90	1.07	2.26	3.31	3.31	4.26	5.12
45/20 °C	T return primary	°C		27	26	26	26	26	26	25	26	24	24	24	24
	Ṽ primary	m³/h		0.86	1.92	2.91	2.91	3.71	4.41	0.85	1.63	2.36	2.36	3.02	3.61
	Q max.	kW		27	63	96	96	124	148	33	65	96	96	123	148
	Ṽ secondary	m³/h		0.96	2.18	3.33	3.33	4.28	5.13	1.16	2.27	3.32	3.32	4.28	5.14

T return primary °C Return temperature primary
 Ṽ primary m³/h Flow rate primary
 Q max. kW Output
 Ṽ secondary m³/h Flow rate secondary

The specified technical data relate to the full load of the module in each case.

Performance data

TransTherm® aqua F (6-10 to 6-50)

Domestic water secondary		TransTherm® aqua F		Flow temperature heating water												
				65 °C (6-...)					70 °C (6-...)							
				(10)	(16)	(20)	(30)	(40)	(50)	(10)	(16)	(20)	(30)	(40)	(50)	
60/5 °C	T return primary	°C	30	30	30	30	30	30	30	30	30	30	30	30	30	30
	V primary	m³/h	1.08	1.88	2.5	3.73	4.84	5.77	1.32	2.09	2.59	3.76	4.82	5.72		
	Q max.	kW	43	75	100	149	193	230	60	95	118	171	219	260		
	V secondary	m³/h	0.67	1.17	1.55	2.33	3.01	3.59	0.94	1.48	1.84	2.67	3.42	4.06		
60/10 °C	T return primary	°C	30	30	30	30	30	30	30	30	30	30	30	30	30	30
	V primary	m³/h	0.8	1.5	2.01	3.16	4.34	5.39	1.08	1.94	2.48	3.77	4.95	5.92		
	Q max.	kW	32	60	80	126	173	215	50	90	115	175	230	275		
	V secondary	m³/h	0.55	1.03	1.38	2.17	2.98	3.7	0.86	1.54	1.98	3.01	3.95	4.73		
60/15 °C	T return primary	°C	30	30	30	30	30	30	30	30	30	30	30	30	30	30
	V primary	m³/h	0.55	1.05	1.38	2.13	3.08	3.96	0.97	1.8	2.37	3.73	4.84	5.72		
	Q max.	kW	22	42	55	85	123	158	44	82	108	170	220	260		
	V secondary	m³/h	0.42	0.8	1.05	1.63	2.35	3.02	0.84	1.57	2.08	3.24	4.21	4.98		
60/20 °C	T return primary	°C	30	30	30	30	30	30	30	30	30	30	30	30	30	30
	V primary	m³/h	0.3	0.6	0.8	1.28	1.75	2.33	0.62	1.14	2.05	2.4	3.43	4.22		
	Q max.	kW	12	24	32	51	70	93	28	52	68	109	156	192		
	V secondary	m³/h	0.26	0.52	0.69	1.1	1.51	2	0.6	1.12	1.47	2.36	3.36	4.14		
55/5 °C	T return primary	°C	30	30	30	30	30	30	30	30	30	30	30	30	30	30
	V primary	m³/h	0.8	1.5	2.01	3.16	4.34	5.39	1.08	2.09	2.53	3.74	4.84	5.76		
	Q max.	kW	32	60	80	126	173	215	50	95	115	170	220	262		
	V secondary	m³/h	0.55	1.03	1.38	2.17	2.98	3.7	0.86	1.63	1.97	2.92	3.78	4.5		
55/10 °C	T return primary	°C	30	30	30	30	30	30	30	30	30	30	30	30	30	30
	V primary	m³/h	1.3	2.06	2.53	3.71	4.81	5.64	1.08	1.87	2.42	3.74	4.84	5.72		
	Q max.	kW	52	82	101	148	192	225	49	85	110	170	220	260		
	V secondary	m³/h	0.99	1.57	1.93	2.83	3.67	4.3	0.94	1.62	2.1	3.24	4.21	4.98		
55/15 °C	T return primary	°C	30	30	30	30	30	30	30	30	30	30	30	30	30	30
	V primary	m³/h	0.97	1.65	2.11	3.71	4.81	5.64	1.1	1.88	2.41	3.74	4.22	5.1		
	Q max.	kW	44	75	96	148	192	225	44	75	96	148	192	232		
	V secondary	m³/h	0.95	1.61	2.07	3.19	4.13	4.84	0.94	1.62	2.1	3.19	4.21	5		
55/20 °C	T return primary	°C	30	30	30	30	30	30	30	30	30	30	30	30	30	30
	V primary	m³/h	0.95	1.68	2.13	3.23	4.24	5.14	0.84	1.47	1.87	2.84	3.72	4.51		
	Q max.	kW	38	67	85	129	169	205	38	67	85	129	169	205		
	V secondary	m³/h	0.94	1.65	2.09	3.18	4.16	5.05	0.94	1.65	2.09	3.18	4.16	5.05		
50/5 °C	T return primary	°C	30	30	30	30	30	30	30	30	30	30	30	30	30	30
	V primary	m³/h	1.25	2.06	2.53	3.71	4.81	5.64	1.08	1.87	2.42	3.56	4.84	5.72		
	Q max.	kW	50	82	101	148	192	225	49	85	110	162	220	260		
	V secondary	m³/h	0.95	1.57	1.93	2.83	3.67	4.3	0.94	1.62	2.1	3.09	4.21	4.98		
50/10 °C	T return primary	°C	30	30	30	30	30	30	30	30	30	30	30	30	30	30
	V primary	m³/h	1.1	1.88	2.41	3.71	4.81	5.64	0.97	1.65	2.11	3.25	4.22	5.1		
	Q max.	kW	44	75	96	148	192	225	44	75	96	148	192	232		
	V secondary	m³/h	0.95	1.61	2.07	3.19	4.13	4.84	0.95	1.61	2.07	3.19	4.13	5		
50/15 °C	T return primary	°C	30	30	30	30	30	30	30	30	30	30	30	30	30	30
	V primary	m³/h	0.95	1.68	2.13	3.23	4.24	5.14	0.84	1.47	1.87	2.84	3.72	4.51		
	Q max.	kW	38	67	85	129	169	205	38	67	85	129	169	205		
	V secondary	m³/h	0.94	1.65	2.09	3.18	4.16	5.05	0.94	1.65	2.09	3.18	4.16	5.05		
50/20 °C	T return primary	°C	30	30	30	30	30	30	30	30	30	30	30	30	30	30
	V primary	m³/h	0.83	1.45	1.81	2.44	3.63	4.44	0.73	1.28	1.61	2.44	3.19	3.89		
	Q max.	kW	33	58	73	111	145	177	33	58	73	111	145	177		
	V secondary	m³/h	0.95	1.67	2.1	3.19	4.17	5.09	0.95	1.67	2.1	3.19	4.17	5.09		
45/5 °C	T return primary	°C	16	15	14	14	14	13	15	13	13	13	12	12	12	12
	V primary	m³/h	0.87	1.83	2.64	2.64	3.38	4.03	0.84	1.62	2.35	2.35	3.01	3.59		
	Q max.	kW	48	104	152	152	196	236	52	104	152	152	196	236		
	V secondary	m³/h	1.04	2.24	3.27	3.27	4.23	5.07	1.13	2.24	3.28	3.28	4.23	5.07		
45/10 °C	T return primary	°C	19	17	17	17	17	16	17	16	16	16	15	15	15	15
	V primary	m³/h	0.87	1.69	2.45	2.45	3.13	3.73	0.77	1.49	2.17	2.17	2.78	3.32		
	Q max.	kW	45	91	134	134	172	206	46	91	133	133	172	206		
	V secondary	m³/h	1.13	2.25	3.30	3.30	4.24	5.09	1.13	2.24	3.29	3.29	4.24	5.09		
45/15 °C	T return primary	°C	21	20	20	20	20	19	20	19	19	19	19	18	18	18
	V primary	m³/h	0.8	1.55	2.24	2.24	2.87	3.43	0.71	1.36	1.98	1.98	2.54	3.03		
	Q max.	kW	39	78	115	115	148	178	40	78	114	114	148	177		
	V secondary	m³/h	1.14	2.27	3.31	3.31	4.26	5.11	1.16	2.26	3.30	3.30	4.26	5.10		
45/20 °C	T return primary	°C	24	23	23	23	23	23	23	23	22	22	22	22	22	22
	V primary	m³/h	0.72	1.4	2.02	2.02	2.59	3.1	0.63	1.22	1.78	1.78	2.29	2.73		
	Q max.	kW	33	66	96	96	123	148	33	65	96	96	124	148		
	V secondary	m³/h	1.16	2.29	3.32	3.32	4.28	5.13	1.15	2.27	3.32	3.32	4.29	5.13		

T return primary °C Return temperature primary
V primary m³/h Flow rate primary
 Q max. kW Output
V secondary m³/h Flow rate secondary
 The specified technical data relate to the full load of the module in each case.

Performance data

TransTherm® aqua F

Residential units standard apartment according to DIN 4708	Peak heat demand standard apartment according to DIN 4708 with preparation 10 min	Sum flow rate domestic hot water calculation flow rate according to DIN 4708	Simultaneity factor according to DIN 4708	Peak flow rate (DHW)	Peak flow rate (DHW)	Peak flow rate (DHW)	Peak output (DHW)	Peak flow rate TransTherm® aqua F (DHW)	Peak flow rate TransTherm® aqua F (DHW)	Peak flow rate TransTherm® aqua F (DHW)	DHW calorifier output TransTherm® aqua F	TransTherm® aqua F	Required heating water volume at 70/30 °C (40 K)	Required heating water buffer storage tank volume at 70/30 °C (40 K)	Buffer storage tank 1 EnerVal	Required recharging capacity	Required recharging capacity	Required recharging capacity
N	Preparation	Σ VR at DHW 60 °C	g	Vs at DHW 60 °C	Vs at DHW 60 °C	Vs at DHW 60 °C		Vs at DHW 60 °C	Vs at DHW 60 °C	Vs at DHW 60 °C	Q at HT 70/30 °C DHW 10/60 °C	Type			Type	Time: 20 min 70/30 °C (40 K)	Time: 30 min 70/30 °C (40 K)	Time: 60 min 70/30 °C (40 K)
	[Wh]	[l/s]		[l/s]	[l/min]	[m³/h]	[kW]	[l/s]	[l/min]	[m³/h]	[kW]		[m³]	[m³]		[kW]	[kW]	[kW]
1	5820	0.17	1.00	0.17	10.01	0.60	35	0.24	14.3	0.86	50	(6-10)	0.13	0.16	(200)	23	15	8
2	11640	0.33	0.680	0.23	13.61	0.82	47	0.24	14.3	0.86	50	(6-10)	0.17	0.22	(200)	31	21	10
3	17460	0.50	0.544	0.27	16.33	0.98	57	0.43	25.8	1.55	90	(6-16)	0.20	0.27	(300)	37	25	12
4	23280	0.67	0.466	0.31	18.66	1.12	65	0.43	25.8	1.55	90	(6-16)	0.23	0.30	(300)	42	28	14
5	29100	0.83	0.415	0.35	20.77	1.25	72	0.43	25.8	1.55	90	(6-16)	0.26	0.34	(500)	47	31	16
6	34920	1.00	0.377	0.38	22.64	1.36	79	0.43	25.8	1.55	90	(6-16)	0.28	0.37	(500)	51	34	17
7	40740	1.17	0.349	0.41	24.45	1.47	85	0.43	25.8	1.55	90	(6-16)	0.31	0.40	(500)	55	37	18
8	46560	1.33	0.349	0.47	27.94	1.68	97	0.55	33.0	1.98	115	(6-20)	0.35	0.45	(500)	63	42	21
9	52380	1.50	0.308	0.46	27.74	1.66	97	0.55	33.0	1.98	115	(6-20)	0.35	0.45	(500)	63	42	21
10	58200	1.67	0.292	0.49	29.23	1.75	102	0.55	33.0	1.98	115	(6-20)	0.37	0.47	(500)	66	44	22
11	64020	1.83	0.279	0.51	30.72	1.84	107	0.55	33.0	1.98	115	(6-20)	0.38	0.50	(500)	70	46	23
12	69840	2.00	0.268	0.54	32.19	1.93	112	0.55	33.0	1.98	115	(6-20)	0.40	0.52	(500)	73	49	24
13	75660	2.17	0.258	0.56	33.57	2.01	117	0.55	33.0	1.98	115	(6-20)	0.42	0.55	(500)	76	51	25
14	81480	2.34	0.249	0.58	34.89	2.09	122	0.84	50.2	3.01	175	(6-30)	0.44	0.57	(500)	79	53	26
15	87300	2.50	0.242	0.61	36.33	2.18	127	0.84	50.2	3.01	175	(6-30)	0.45	0.59	(800)	82	55	27
16	93120	2.67	0.235	0.63	37.63	2.26	131	0.84	50.2	3.01	175	(6-30)	0.47	0.61	(800)	85	57	28
17	98940	2.84	0.228	0.65	38.79	2.33	135	0.84	50.2	3.01	175	(6-30)	0.49	0.63	(800)	88	59	29
18	104760	3.00	0.223	0.67	40.17	2.41	140	0.84	50.2	3.01	175	(6-30)	0.50	0.65	(800)	91	61	30
19	110580	3.17	0.217	0.69	41.27	2.48	144	0.84	50.2	3.01	175	(6-30)	0.52	0.67	(800)	94	62	31
20	116400	3.34	0.212	0.71	42.44	2.55	148	0.84	50.2	3.01	175	(6-30)	0.53	0.69	(800)	96	64	32
21	122220	3.50	0.208	0.73	43.72	2.62	153	0.84	50.2	3.01	175	(6-30)	0.55	0.71	(800)	99	66	33
22	128040	3.67	0.204	0.75	44.92	2.70	157	0.84	50.2	3.01	175	(6-30)	0.56	0.73	(800)	102	68	34
23	133860	3.84	0.200	0.77	46.04	2.76	161	0.84	50.2	3.01	175	(6-30)	0.58	0.75	(800)	104	70	35
24	139680	4.00	0.196	0.78	47.08	2.82	164	0.84	50.2	3.01	175	(6-30)	0.59	0.77	(800)	107	71	36
25	145500	4.17	0.193	0.80	48.29	2.90	168	0.84	50.2	3.01	175	(6-30)	0.60	0.78	(800)	110	73	37
26	151320	4.34	0.190	0.82	49.44	2.97	173	0.84	50.2	3.01	175	(6-30)	0.62	0.80	(800)	112	75	37
27	157140	4.50	0.187	0.84	50.53	3.03	176	0.84	50.2	3.01	175	(6-30)	0.63	0.82	(800)	115	76	38
28	162960	4.67	0.184	0.86	51.56	3.09	180	0.84	50.2	3.01	175	(6-30)	0.64	0.84	(800)	117	78	39
29	168780	4.84	0.181	0.88	52.54	3.15	183	1.10	65.8	3.95	230	(6-40)	0.66	0.85	(800)	119	79	40
30	174600	5.00	0.179	0.90	53.75	3.22	188	1.10	65.8	3.95	230	(6-40)	0.67	0.87	(1000)	122	81	41
31	180420	5.17	0.176	0.91	54.61	3.28	191	1.10	65.8	3.95	230	(6-40)	0.68	0.89	(1000)	124	83	41
32	186240	5.34	0.174	0.93	55.73	3.34	194	1.10	65.8	3.95	230	(6-40)	0.70	0.91	(1000)	126	84	42
33	192060	5.50	0.172	0.95	56.81	3.41	198	1.10	65.8	3.95	230	(6-40)	0.71	0.92	(1000)	129	86	43
34	197880	5.67	0.170	0.96	57.85	3.47	202	1.10	65.8	3.95	230	(6-40)	0.72	0.94	(1000)	131	87	44
35	203700	5.84	0.168	0.98	58.85	3.53	205	1.10	65.8	3.95	230	(6-40)	0.74	0.96	(1000)	133	89	44
36	209520	6.01	0.166	1.00	59.81	3.59	209	1.10	65.8	3.95	230	(6-40)	0.75	0.97	(1000)	136	90	45
37	215340	6.17	0.164	1.01	60.73	3.64	212	1.10	65.8	3.95	230	(6-40)	0.76	0.99	(1000)	138	92	46
38	221160	6.34	0.163	1.03	61.99	3.72	216	1.10	65.8	3.95	230	(6-40)	0.78	1.01	(1000)	141	94	47
39	226980	6.51	0.161	1.05	62.84	3.77	219	1.10	65.8	3.95	230	(6-40)	0.79	1.02	(1000)	143	95	48
40	232800	6.67	0.159	1.06	63.65	3.82	222	1.10	65.8	3.95	230	(6-40)	0.80	1.03	(1000)	144	96	48
41	238620	6.84	0.158	1.08	64.84	3.89	226	1.10	65.8	3.95	230	(6-40)	0.81	1.05	(1000)	147	98	49
42	244440	7.01	0.156	1.09	65.58	3.93	229	1.10	65.8	3.95	230	(6-40)	0.82	1.07	(1000)	149	99	50
43	250260	7.17	0.155	1.11	66.71	4.00	233	1.10	65.8	3.95	230	(6-40)	0.83	1.08	(1000)	151	101	50
44	256080	7.34	0.154	1.13	67.82	4.07	237	1.31	78.8	4.73	275	(6-50)	0.85	1.10	(1500)	154	103	51
45	261900	7.51	0.152	1.14	68.46	4.11	239	1.31	78.8	4.73	275	(6-50)	0.86	1.11	(1500)	155	104	52
46	267720	7.67	0.151	1.16	69.52	4.17	243	1.31	78.8	4.73	275	(6-50)	0.87	1.13	(1500)	158	105	53
47	273540	7.84	0.150	1.18	70.56	4.23	246	1.31	78.8	4.73	275	(6-50)	0.88	1.15	(1500)	160	107	53
48	279360	8.01	0.149	1.19	71.58	4.29	250	1.31	78.8	4.73	275	(6-50)	0.89	1.16	(1500)	162	108	54
49	285180	8.17	0.148	1.21	72.58	4.35	253	1.31	78.8	4.73	275	(6-50)	0.91	1.18	(1500)	165	110	55
50	291000	8.34	0.146	1.22	73.06	4.38	255	1.31	78.8	4.73	275	(6-50)	0.91	1.19	(1500)	166	110	55
51	296820	8.51	0.145	1.23	74.01	4.44	258	1.31	78.8	4.73	275	(6-50)	0.93	1.20	(1500)	168	112	56
52	302640	8.67	0.144	1.25	74.94	4.50	261	1.31	78.8	4.73	275	(6-50)	0.94	1.22	(1500)	170	113	57
53	308460	8.84	0.143	1.26	75.86	4.55	265	1.31	78.8	4.73	275	(6-50)	0.95	1.23	(1500)	172	115	57
54	314280	9.01	0.142	1.28	76.75	4.60	268	1.31	78.8	4.73	275	(6-50)	0.96	1.25	(1500)	174	116	58

Residential units standard apartment according to DIN 4708	Peak heat demand standard apartment according to DIN 4708 with preparation 10 min	Sum flow rate domestic hot water calculation flow rate according to DIN 4708	Simultaneity factor according to DIN 4708	Peak flow rate (DHW)	Peak flow rate (DHW)	Peak flow rate (DHW)	Peak output (DHW)	Peak flow rate TransTherm® aqua F (DHW)	Peak flow rate TransTherm® aqua F (DHW)	Peak flow rate TransTherm® aqua F (DHW)	DHW calorifier output TransTherm® aqua F	TransTherm® aqua F	Required heating water volume at 70/30 °C (40 K)	Required heating water buffer storage tank volume at 70/30 °C (40 K)	Buffer storage tank 1 EnerVal	Required recharging capacity	Required recharging capacity	Required recharging capacity
	[Wh]	[l/s]		[l/s]	[l/min]	[m³/h]	[kW]	[l/s]	[l/min]	[m³/h]	[kW]		[m³]	[m³]		[kW]	[kW]	[kW]
55	320 100	9.17	0.141	1.29	77.62	4.66	271	1.31	78.8	4.73	275	(6-50)	0.97	1.26	(1500)	176	117	59
56	325 920	9.34	0.140	1.31	78.47	4.71	274	1.31	78.8	4.73	275	(6-50)	0.98	1.28	(1500)	178	119	59
57	331 740	9.51	0.140	1.33	79.87	4.79	279	1.31	78.8	4.73	275	(6-50)	1.00	1.30	(1500)	181	121	60
58	337 560	9.67	0.139	1.34	80.69	4.84	282	1.69	101.2	6.07	350	(6-60)	1.01	1.31	(1500)	183	122	61
59	343 380	9.84	0.138	1.36	81.49	4.89	284	1.69	101.2	6.07	350	(6-60)	1.02	1.32	(1500)	185	123	62
60	349 200	10.01	0.137	1.37	82.27	4.94	287	1.69	101.2	6.07	350	(6-60)	1.03	1.34	(1500)	187	124	62
61	355 020	10.18	0.136	1.38	83.03	4.98	290	1.69	101.2	6.07	350	(6-60)	1.04	1.35	(1500)	188	126	63
62	360 840	10.34	0.135	1.40	83.77	5.03	292	1.69	101.2	6.07	350	(6-60)	1.05	1.36	(1500)	190	127	63
63	366 660	10.51	0.135	1.42	85.12	5.11	297	1.69	101.2	6.07	350	(6-60)	1.06	1.38	(1500)	193	129	64
64	372 480	10.68	0.134	1.43	85.83	5.15	299	1.69	101.2	6.07	350	(6-60)	1.07	1.40	(1500)	195	130	65
65	378 300	10.84	0.133	1.44	86.52	5.19	302	1.69	101.2	6.07	350	(6-60)	1.08	1.41	(1500)	196	131	65
66	384 120	11.01	0.132	1.45	87.19	5.23	304	1.69	101.2	6.07	350	(6-60)	1.09	1.42	(1500)	198	132	66
67	389 940	11.18	0.132	1.48	88.52	5.31	309	1.69	101.2	6.07	350	(6-60)	1.11	1.44	(1500)	201	134	67
68	395 760	11.34	0.131	1.49	89.16	5.35	311	1.69	101.2	6.07	350	(6-60)	1.11	1.45	(1500)	202	135	67
69	401 580	11.51	0.130	1.50	89.78	5.39	313	1.69	101.2	6.07	350	(6-60)	1.12	1.46	(1500)	204	136	68
70	407 400	11.68	0.130	1.52	91.08	5.46	318	1.69	101.2	6.07	350	(6-60)	1.14	1.48	(1500)	207	138	69
71	413 220	11.84	0.129	1.53	91.67	5.50	320	1.69	101.2	6.07	350	(6-60)	1.15	1.49	(1500)	208	139	69
72	419 040	12.01	0.128	1.54	92.24	5.53	322	1.69	101.2	6.07	350	(6-60)	1.15	1.50	(1500)	209	139	70
73	424 860	12.18	0.128	1.56	93.52	5.61	326	1.69	101.2	6.07	350	(6-60)	1.17	1.52	(1500)	212	141	71
74	430 680	12.34	0.127	1.57	94.06	5.64	328	1.69	101.2	6.07	350	(6-60)	1.18	1.53	(1500)	213	142	71
75	436 500	12.51	0.127	1.59	95.33	5.72	333	1.69	101.2	6.07	350	(6-60)	1.19	1.55	(1500)	216	144	72
76	442 320	12.68	0.126	1.60	95.84	5.75	334	1.69	101.2	6.07	350	(6-60)	1.20	1.56	(1500)	217	145	72
77	448 140	12.84	0.126	1.62	97.10	5.83	339	1.69	101.2	6.07	350	(6-60)	1.21	1.58	(1500)	220	147	73
78	453 960	13.01	0.125	1.63	97.58	5.86	340	1.69	101.2	6.07	350	(6-60)	1.22	1.59	(1500)	221	148	74
79	459 780	13.18	0.124	1.63	98.04	5.88	342	1.69	101.2	6.07	350	(6-60)	1.23	1.59	(1500)	222	148	74
80	465 600	13.34	0.124	1.65	99.29	5.96	346	1.69	101.2	6.07	350	(6-60)	1.24	1.61	(2000)	225	150	75
81	471 420	13.51	0.123	1.66	99.72	5.98	348	1.69	101.2	6.07	350	(6-60)	1.25	1.62	(2000)	226	151	75
82	477 240	13.68	0.123	1.68	100.95	6.06	352	1.69	101.2	6.07	350	(6-60)	1.26	1.64	(2000)	229	153	76
83	483 060	13.85	0.122	1.69	101.35	6.08	354	1.69	101.2	6.07	350	(6-60)	1.27	1.65	(2000)	230	153	77
84	488 880	14.01	0.122	1.71	102.57	6.15	358	2.17	130.0	7.80	450	(6-70)	1.28	1.67	(2000)	233	155	78
85	494 700	14.18	0.121	1.72	102.94	6.18	359	2.17	130.0	7.80	450	(6-70)	1.29	1.67	(2000)	233	156	78
86	500 520	14.35	0.121	1.74	104.15	6.25	363	2.17	130.0	7.80	450	(6-70)	1.30	1.69	(2000)	236	157	79
87	506 340	14.51	0.120	1.74	104.49	6.27	365	2.17	130.0	7.80	450	(6-70)	1.31	1.70	(2000)	237	158	79
88	512 160	14.68	0.120	1.76	105.69	6.34	369	2.17	130.0	7.80	450	(6-70)	1.32	1.72	(2000)	240	160	80
89	517 980	14.85	0.120	1.78	106.89	6.41	373	2.17	130.0	7.80	450	(6-70)	1.34	1.74	(2000)	242	162	81
90	523 800	15.01	0.119	1.79	107.19	6.43	374	2.17	130.0	7.80	450	(6-70)	1.34	1.74	(2000)	243	162	81
91	529 620	15.18	0.119	1.81	108.38	6.50	378	2.17	130.0	7.80	450	(6-70)	1.36	1.76	(2000)	246	164	82
92	535 440	15.35	0.118	1.81	108.65	6.52	379	2.17	130.0	7.80	450	(6-70)	1.36	1.77	(2000)	246	164	82
93	541 260	15.51	0.118	1.83	109.83	6.59	383	2.17	130.0	7.80	450	(6-70)	1.37	1.79	(2000)	249	166	83
94	547 080	15.68	0.117	1.83	110.07	6.60	384	2.17	130.0	7.80	450	(6-70)	1.38	1.79	(2000)	250	166	83
95	552 900	15.85	0.117	1.85	111.25	6.67	388	2.17	130.0	7.80	450	(6-70)	1.39	1.81	(2000)	252	168	84
96	558 720	16.01	0.117	1.87	112.42	6.74	392	2.17	130.0	7.80	450	(6-70)	1.41	1.83	(2000)	255	170	85
97	564 540	16.18	0.116	1.88	112.62	6.76	393	2.17	130.0	7.80	450	(6-70)	1.41	1.83	(2000)	255	170	85
98	570 360	16.35	0.116	1.90	113.78	6.83	397	2.17	130.0	7.80	450	(6-70)	1.42	1.85	(2000)	258	172	86
99	576 180	16.51	0.116	1.92	114.94	6.90	401	2.17	130.0	7.80	450	(6-70)	1.44	1.87	(2000)	261	174	87
100	582 000	16.68	0.115	1.92	115.10	6.91	402	2.17	130.0	7.80	450	(6-70)	1.44	1.87	(2000)	261	174	87

Performance data

TransTherm® aqua F

N	Residential units standard apartment according to DIN 4708	Peak heat demand standard apartment according to DIN 4708 with preparation 10 min	Sum flow rate domestic hot water calculation flow rate according to DIN 4708	Simultaneity factor according to DIN 4708	Peak flow rate (DHW)	Peak flow rate (DHW)	Peak flow rate (DHW)	Peak output (DHW)	Peak flow rate TransTherm® aqua F (DHW)	Peak flow rate TransTherm® aqua F (DHW)	Peak flow rate TransTherm® aqua F (DHW)	DHW calorifier output TransTherm® aqua F	TransTherm® aqua F	Required heating water volume at 65/30 °C (35 K)	Required heating water buffer storage tank volume at 65/30 °C (35 K)	Buffer storage tank 1 EnerVal	Required recharging capacity	Required recharging capacity	Required recharging capacity
	Preparation	Σ VR at DHW 60 °C	g	Vs at DHW 60 °C	Vs at DHW 60 °C	Vs at DHW 60 °C		Vs at DHW 60 °C	Vs at DHW 60 °C	Vs at DHW 60 °C	Q at HT 65/30 °C DHW 10/60 °C	Type			Type	Time: 20 min 65/30 °C (35 K)	Time: 30 min 65/30 °C (35 K)	Time: 60 min 65/30 °C (35 K)	
	[Wh]	[l/s]		[l/s]	[l/min]	[m³/h]	[kW]	[l/s]	[l/min]	[m³/h]	[kW]		[m³]	[m³]		[kW]	[kW]	[kW]	
1	5820	0.17	1.00	0.17	10.01	0.60	35	0.15	9.2	0.55	32	(6-10)	0.14	0.19	(200)	23	15	8	
2	11640	0.33	0.680	0.23	13.61	0.82	47	0.24	14.3	0.86	60	(6-16)	0.19	0.25	(200)	31	21	10	
3	17460	0.50	0.544	0.27	16.33	0.98	57	0.43	25.8	1.55	60	(6-16)	0.23	0.30	(300)	37	25	12	
4	23280	0.67	0.466	0.31	18.66	1.12	65	0.38	23.0	1.38	80	(6-20)	0.27	0.35	(300)	42	28	14	
5	29100	0.83	0.415	0.35	20.77	1.25	72	0.38	23.0	1.38	80	(6-20)	0.30	0.39	(500)	47	31	16	
6	34920	1.00	0.377	0.38	22.64	1.36	79	0.38	23.0	1.38	80	(6-20)	0.32	0.42	(500)	51	34	17	
7	40740	1.17	0.349	0.41	24.45	1.47	85	0.60	36.2	2.17	126	(6-30)	0.35	0.45	(500)	55	37	18	
8	46560	1.33	0.349	0.47	27.94	1.68	97	0.60	36.2	2.17	126	(6-30)	0.40	0.52	(500)	63	42	21	
9	52380	1.50	0.308	0.46	27.74	1.66	97	0.60	36.2	2.17	126	(6-30)	0.40	0.52	(500)	63	42	21	
10	58200	1.67	0.292	0.49	29.23	1.75	102	0.60	36.2	2.17	126	(6-30)	0.42	0.54	(500)	66	44	22	
11	64020	1.83	0.279	0.51	30.72	1.84	107	0.60	36.2	2.17	126	(6-30)	0.44	0.57	(500)	70	46	23	
12	69840	2.00	0.268	0.54	32.19	1.93	112	0.60	36.2	2.17	126	(6-30)	0.46	0.60	(500)	73	49	24	
13	75660	2.17	0.258	0.56	33.57	2.01	117	0.60	36.2	2.17	126	(6-30)	0.48	0.62	(500)	76	51	25	
14	81480	2.34	0.249	0.58	34.89	2.09	122	0.60	36.2	2.17	126	(6-30)	0.50	0.65	(500)	79	53	26	
15	87300	2.50	0.242	0.61	36.33	2.18	127	0.60	36.2	2.17	126	(6-30)	0.52	0.67	(800)	82	55	27	
16	93120	2.67	0.235	0.63	37.63	2.26	131	0.83	49.7	2.98	173	(6-40)	0.54	0.70	(800)	85	57	28	
17	98940	2.84	0.228	0.65	38.79	2.33	135	0.83	49.7	2.98	173	(6-40)	0.55	0.72	(800)	88	59	29	
18	104760	3.00	0.223	0.67	40.17	2.41	140	0.83	49.7	2.98	173	(6-40)	0.57	0.75	(800)	91	61	30	
19	110580	3.17	0.217	0.69	41.27	2.48	144	0.83	49.7	2.98	173	(6-40)	0.59	0.77	(800)	94	62	31	
20	116400	3.34	0.212	0.71	42.44	2.55	148	0.83	49.7	2.98	173	(6-40)	0.61	0.79	(800)	96	64	32	
21	122220	3.50	0.208	0.73	43.72	2.62	153	0.83	49.7	2.98	173	(6-40)	0.62	0.81	(800)	99	66	33	
22	128040	3.67	0.204	0.75	44.92	2.70	157	0.83	49.7	2.98	173	(6-40)	0.64	0.83	(800)	102	68	34	
23	133860	3.84	0.200	0.77	46.04	2.76	161	0.83	49.7	2.98	173	(6-40)	0.66	0.86	(800)	104	70	35	
24	139680	4.00	0.196	0.78	47.08	2.82	164	0.83	49.7	2.98	173	(6-40)	0.67	0.87	(800)	107	71	36	
25	145500	4.17	0.193	0.80	48.29	2.90	168	0.83	49.7	2.98	173	(6-40)	0.69	0.90	(800)	110	73	37	
26	151320	4.34	0.190	0.82	49.44	2.97	173	0.83	49.7	2.98	173	(6-40)	0.71	0.92	(800)	112	75	37	
27	157140	4.50	0.187	0.84	50.53	3.03	176	0.83	49.7	2.98	173	(6-40)	0.72	0.94	(800)	115	76	38	
28	162960	4.67	0.184	0.86	51.56	3.09	180	1.03	61.7	3.70	215	(6-50)	0.74	0.96	(800)	117	78	39	
29	168780	4.84	0.181	0.88	52.54	3.15	183	1.03	61.7	3.70	215	(6-50)	0.75	0.98	(800)	119	79	40	
30	174600	5.00	0.179	0.90	53.75	3.22	188	1.03	61.7	3.70	215	(6-50)	0.77	1.00	(1000)	122	81	41	
31	180420	5.17	0.176	0.91	54.61	3.28	191	1.03	61.7	3.70	215	(6-50)	0.78	1.01	(1000)	124	83	41	
32	186240	5.34	0.174	0.93	55.73	3.34	194	1.03	61.7	3.70	215	(6-50)	0.80	1.04	(1000)	126	84	42	
33	192060	5.50	0.172	0.95	56.81	3.41	198	1.03	61.7	3.70	215	(6-50)	0.81	1.06	(1000)	129	86	43	
34	197880	5.67	0.170	0.96	57.85	3.47	202	1.03	61.7	3.70	215	(6-50)	0.83	1.07	(1000)	131	87	44	
35	203700	5.84	0.168	0.98	58.85	3.53	205	1.03	61.7	3.70	215	(6-50)	0.84	1.09	(1000)	133	89	44	
36	209520	6.01	0.166	1.00	59.81	3.59	209	1.03	67.7	3.70	215	(6-50)	0.85	1.11	(1000)	136	90	45	
37	215340	6.17	0.164	1.01	60.73	3.64	212	1.03	61.7	3.70	215	(6-50)	0.87	1.13	(1000)	138	92	46	
38	221160	6.34	0.163	1.03	61.99	3.72	216	1.03	61.7	3.70	215	(6-50)	0.89	1.15	(1000)	141	94	47	
39	226980	6.51	0.161	1.05	62.84	3.77	219	1.06	63.7	3.82	220	(6-60)	0.90	1.17	(1000)	143	95	48	
40	232800	6.67	0.159	1.06	63.65	3.82	222	1.06	63.7	3.82	220	(6-60)	0.91	1.18	(1000)	144	96	48	
41	238620	6.84	0.158	1.08	64.84	3.89	226	1.35	81.0	4.86	280	(6-70)	0.93	1.20	(1000)	147	98	49	
42	244440	7.01	0.156	1.09	65.58	3.93	229	1.35	81.0	4.86	280	(6-70)	0.94	1.22	(1000)	149	99	50	
43	250260	7.17	0.155	1.11	66.71	4.00	233	1.35	81.0	4.86	280	(6-70)	0.95	1.24	(1000)	151	101	50	
44	256080	7.34	0.154	1.13	67.82	4.07	237	1.35	81.0	4.86	280	(6-70)	0.97	1.26	(1500)	154	103	51	
45	261900	7.51	0.152	1.14	68.46	4.11	239	1.35	81.0	4.86	280	(6-70)	0.98	1.27	(1500)	155	104	52	
46	267720	7.67	0.151	1.16	69.52	4.17	243	1.35	81.0	4.86	280	(6-70)	0.99	1.29	(1500)	158	105	53	
47	273540	7.84	0.150	1.18	70.56	4.23	246	1.35	81.0	4.86	280	(6-70)	1.01	1.31	(1500)	160	107	53	
48	279360	8.01	0.149	1.19	71.58	4.29	250	1.35	81.0	4.86	280	(6-70)	1.02	1.33	(1500)	162	108	54	
49	285180	8.17	0.148	1.21	72.58	4.35	253	1.35	81.0	4.86	280	(6-70)	1.04	1.35	(1500)	165	110	55	
50	291000	8.34	0.146	1.22	73.06	4.38	255	1.35	81.0	4.86	280	(6-70)	1.04	1.36	(1500)	166	110	55	
51	296820	8.51	0.145	1.23	74.01	4.44	258	1.35	81.0	4.86	280	(6-70)	1.06	1.37	(1500)	168	112	56	
52	302640	8.67	0.144	1.25	74.94	4.50	261	1.35	81.0	4.86	280	(6-70)	1.07	1.39	(1500)	170	113	57	
53	308460	8.84	0.143	1.26	75.86	4.55	265	1.35	81.0	4.86	280	(6-70)	1.08	1.41	(1500)	172	115	57	
54	314280	9.01	0.142	1.28	76.75	4.60	268	1.35	81.0	4.86	280	(6-70)	1.10	1.43	(1500)	174	116	58	

Residential units standard apartment according to DIN 4708	Peak heat demand standard apartment according to DIN 4708 with preparation 10 min	Sum flow rate domestic hot water calculation flow rate according to DIN 4708	Simultaneity factor according to DIN 4708	Peak flow rate (DHW)	Peak flow rate (DHW)	Peak flow rate (DHW)	Peak output (DHW)	Peak flow rate TransTherm® aqua F (DHW)	Peak flow rate TransTherm® aqua F (DHW)	Peak flow rate TransTherm® aqua F (DHW)	DHW calorifier output TransTherm® aqua F	TransTherm® aqua F	Required heating water volume at 65/30 °C (35 K)	Required heating water buffer storage tank volume at 65/30 °C (35 K)	Buffer storage tank 1 EnerVal	Required recharging capacity	Required recharging capacity	Required recharging capacity
	[Wh]	[l/s]		[l/s]	[l/min]	[m³/h]	[kW]	[l/s]	[l/min]	[m³/h]	[kW]		[m³]	[m³]		[kW]	[kW]	[kW]
55	320 100	9.17	0.141	1.29	77.62	4.66	271	1.35	81.0	4.86	280	(6-70)	1.11	1.44	(1500)	176	117	59
56	325 920	9.34	0.140	1.31	78.47	4.71	274	1.35	81.0	4.86	280	(6-70)	1.12	1.46	(1500)	178	119	59
57	331 740	9.51	0.140	1.33	79.87	4.79	279	1.35	81.0	4.86	280	(6-70)	1.14	1.48	(1500)	181	121	60
58	337 560	9.67	0.139	1.34	80.69	4.84	282	1.83	109.8	6.59	380	(6-80)	1.15	1.50	(1500)	183	122	61
59	343 380	9.84	0.138	1.36	81.49	4.89	284	1.83	109.8	6.59	380	(6-80)	1.16	1.51	(1500)	185	123	62
60	349 200	10.01	0.137	1.37	82.27	4.94	287	1.83	109.8	6.59	380	(6-80)	1.18	1.53	(1500)	187	124	62
61	355 020	10.18	0.136	1.38	83.03	4.98	290	1.83	109.8	6.59	380	(6-80)	1.19	1.54	(1500)	188	126	63
62	360 840	10.34	0.135	1.40	83.77	5.03	292	1.83	109.8	6.59	380	(6-80)	1.20	1.56	(1500)	190	127	63
63	366 660	10.51	0.135	1.42	85.12	5.11	297	1.83	109.8	6.59	380	(6-80)	1.22	1.58	(1500)	193	129	64
64	372 480	10.68	0.134	1.43	85.83	5.15	299	1.83	109.8	6.59	380	(6-80)	1.23	1.59	(1500)	195	130	65
65	378 300	10.84	0.133	1.44	86.52	5.19	302	1.83	109.8	6.59	380	(6-80)	1.24	1.61	(1500)	196	131	65
66	384 120	11.01	0.132	1.45	87.19	5.23	304	1.83	109.8	6.59	380	(6-80)	1.25	1.62	(1500)	198	132	66
67	389 940	11.18	0.132	1.48	88.52	5.31	309	1.83	109.8	6.59	380	(6-80)	1.26	1.64	(1500)	201	134	67
68	395 760	11.34	0.131	1.49	89.16	5.35	311	1.83	109.8	6.59	380	(6-80)	1.27	1.66	(1500)	202	135	67
69	401 580	11.51	0.130	1.50	89.78	5.39	313	1.83	109.8	6.59	380	(6-80)	1.28	1.67	(1500)	204	136	68
70	407 400	11.68	0.130	1.52	91.08	5.46	318	1.83	109.8	6.59	380	(6-80)	1.30	1.69	(1500)	207	138	69
71	413 220	11.84	0.129	1.53	91.67	5.50	320	1.83	109.8	6.59	380	(6-80)	1.31	1.70	(1500)	208	139	69
72	419 040	12.01	0.128	1.54	92.24	5.53	322	1.83	109.8	6.59	380	(6-80)	1.32	1.71	(1500)	209	139	70
73	424 860	12.18	0.128	1.56	93.52	5.61	326	1.83	109.8	6.59	380	(6-80)	1.34	1.74	(1500)	212	141	71
74	430 680	12.34	0.127	1.57	94.06	5.64	328	1.83	109.8	6.59	380	(6-80)	1.34	1.75	(1500)	213	142	71
75	436 500	12.51	0.127	1.59	95.33	5.72	333	1.83	109.8	6.59	380	(6-80)	1.36	1.77	(1500)	216	144	72
76	442 320	12.68	0.126	1.60	95.84	5.75	334	1.83	109.8	6.59	380	(6-80)	1.37	1.78	(1500)	217	145	72
77	448 140	12.84	0.126	1.62	97.10	5.83	339	1.83	109.8	6.59	380	(6-80)	1.39	1.80	(1500)	220	147	73
78	453 960	13.01	0.125	1.63	97.58	5.86	340	1.83	109.8	6.59	380	(6-80)	1.39	1.81	(1500)	221	148	74
79	459 780	13.18	0.124	1.63	98.04	5.88	342	1.83	109.8	6.59	380	(6-80)	1.40	1.82	(1500)	222	148	74
80	465 600	13.34	0.124	1.65	99.29	5.96	346	1.83	109.8	6.59	380	(6-80)	1.42	1.84	(2000)	225	150	75
81	471 420	13.51	0.123	1.66	99.72	5.98	348	1.83	109.8	6.59	380	(6-80)	1.42	1.85	(2000)	226	151	75
82	477 240	13.68	0.123	1.68	100.95	6.06	352	1.83	109.8	6.59	380	(6-80)	1.44	1.88	(2000)	229	153	76
83	483 060	13.85	0.122	1.69	101.35	6.08	354	1.83	109.8	6.59	380	(6-80)	1.45	1.88	(2000)	230	153	77
84	488 880	14.01	0.122	1.71	102.57	6.15	358	1.83	109.8	6.59	380	(6-80)	1.47	1.91	(2000)	233	155	78
85	494 700	14.18	0.121	1.72	102.94	6.18	359	1.83	109.8	6.59	380	(6-80)	1.47	1.91	(2000)	233	156	78
86	500 520	14.35	0.121	1.74	104.15	6.25	363	1.83	109.8	6.59	380	(6-80)	1.49	1.93	(2000)	236	157	79
87	506 340	14.51	0.120	1.74	104.49	6.27	365	1.83	109.8	6.59	380	(6-80)	1.49	1.94	(2000)	237	158	79
88	512 160	14.68	0.120	1.76	105.69	6.34	369	1.83	109.8	6.59	380	(6-80)	1.51	1.96	(2000)	240	160	80
89	517 980	14.85	0.120	1.78	106.89	6.41	373	1.83	109.8	6.59	380	(6-80)	1.53	1.99	(2000)	242	162	81
90	523 800	15.01	0.119	1.79	107.19	6.43	374	1.83	109.8	6.59	380	(6-80)	1.53	1.99	(2000)	243	162	81
91	529 620	15.18	0.119	1.81	108.38	6.50	378	1.83	109.8	6.59	380	(6-80)	1.55	2.01	(2000)	246	164	82
92	535 440	15.35	0.118	1.81	108.65	6.52	379	1.83	109.8	6.59	380	(6-80)	1.55	2.02	(2000)	246	164	82
93	541 260	15.51	0.118	1.83	109.83	6.59	383	1.83	109.8	6.59	380	(6-80)	1.57	2.04	(2000)	249	166	83
94	547 080	15.68	0.117	1.83	110.07	6.60	384	1.83	109.8	6.59	380	(6-80)	1.57	2.04	(2000)	250	166	83
95	552 900	15.85	0.117	1.85	111.25	6.67	388	2.51	150.3	9.02	520	(6-90)	1.59	2.07	(2000)	252	168	84
96	558 720	16.01	0.117	1.87	112.42	6.74	392	2.51	150.3	9.02	520	(6-90)	1.61	2.09	(2000)	255	170	85
97	564 540	16.18	0.116	1.88	112.62	6.76	393	2.51	150.3	9.02	520	(6-90)	1.61	2.09	(2000)	255	170	85
98	570 360	16.35	0.116	1.90	113.78	6.83	397	2.51	150.3	9.02	520	(6-90)	1.63	2.11	(2000)	258	172	86
99	576 180	16.51	0.116	1.92	114.94	6.90	401	2.51	150.3	9.02	520	(6-90)	1.64	2.13	(2000)	261	174	87
100	582 000	16.68	0.115	1.92	115.10	6.91	402	2.51	150.3	9.02	520	(6-90)	1.64	2.14	(2000)	261	174	87

Pressure drop ($\Delta P / Q$ max) – domestic water side (secondary)

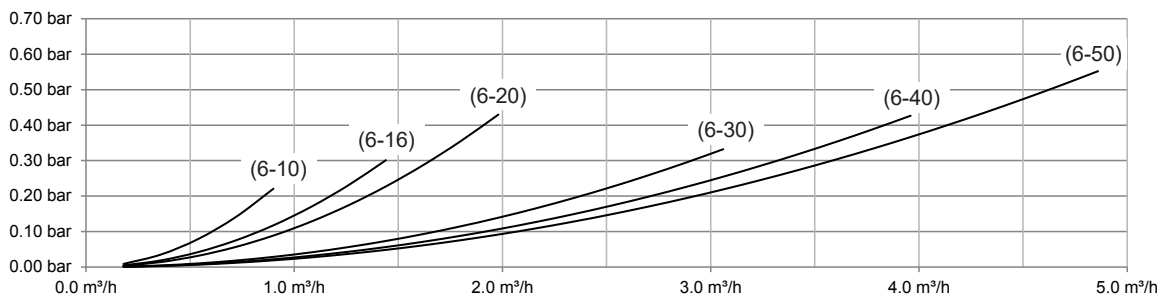

Circulating pumps characteristic curves

for circulation set 3/4"

$\Delta p-v$ (variable)

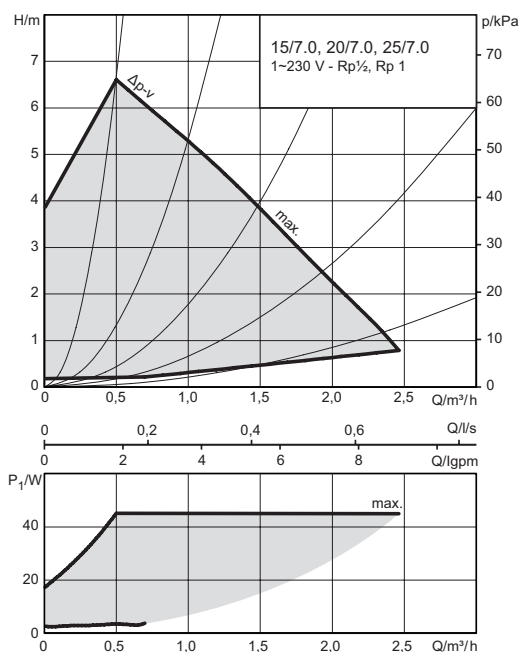

Constant speed

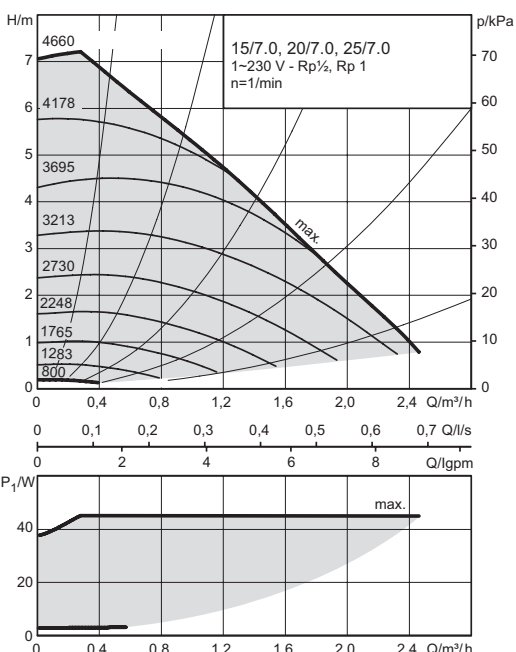

for circulation set 1" and 1¼"

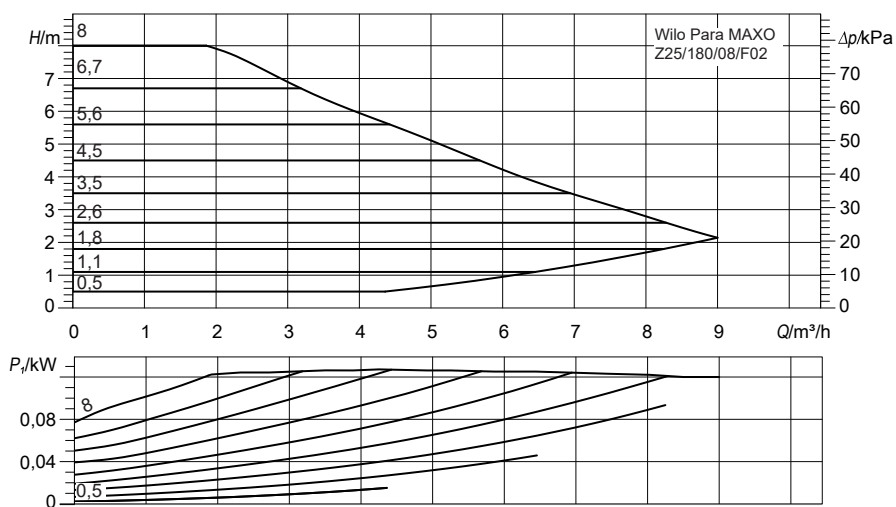

Fresh water module TransTherm® aqua F (6-10 to 6-20)
(Dimensions in mm)

*** For application according to the SVGW**
The installation of ball valves is not permitted in Switzerland according to SVGW regulation W3.

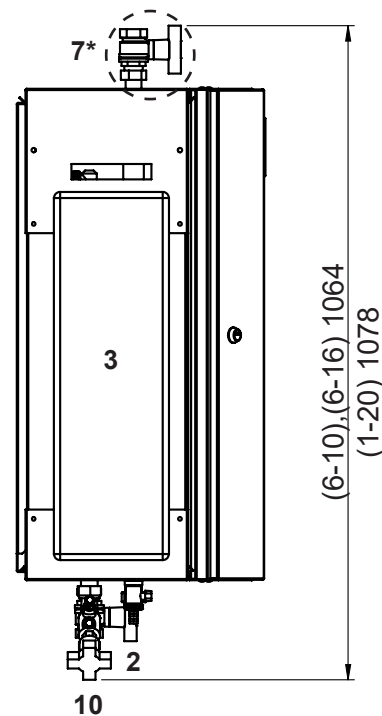
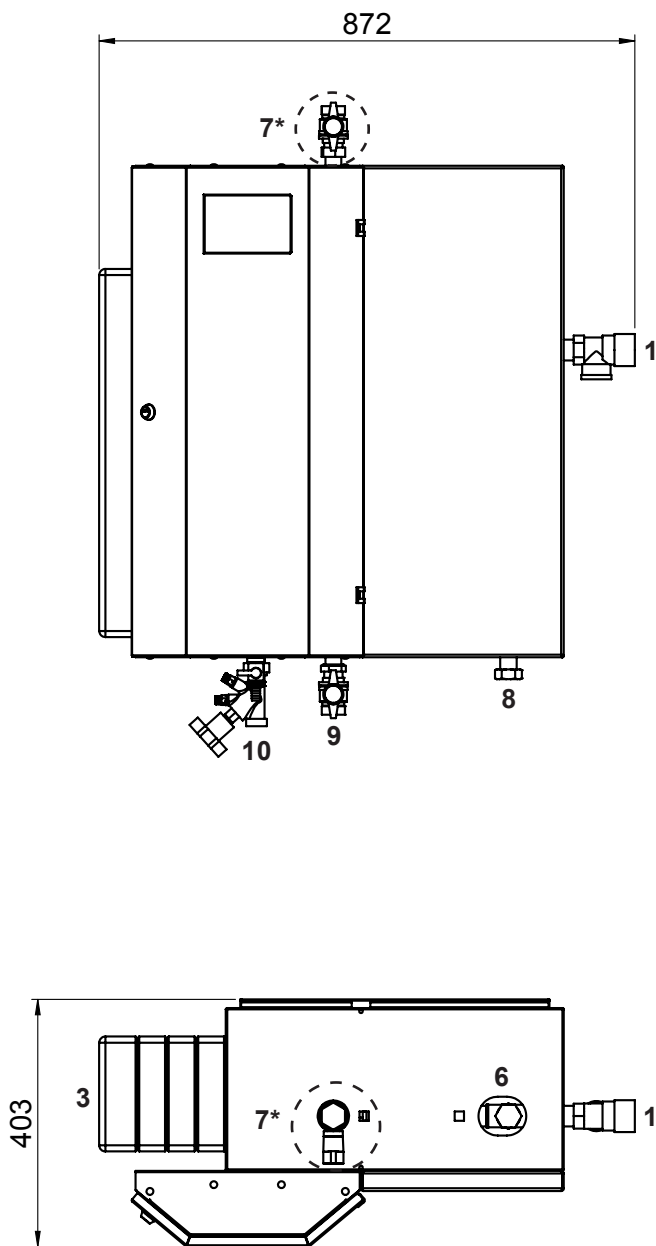

- 1 Safety valve
Hot water 10 bar
- 2 Filling/drain valve
- 3 Heat exchanger

	(6-10)	(6-16)	(6-20)
6 Circulation ¹⁾	DN 25, Rp 1" (20, Rp ¾") (IT)		
7* Hot water	DN 25, Rp 1" (IT)		
8 Cold water	DN 25, Gp 1" (IT)		
9 Flow heating water	DN 25, Rp 1" (IT)		
10 Return heating water	DN 20, Gp 1" (IT)		

¹⁾ Optional, connection and installation on site

Gp = straight internal thread

TransTherm® aqua F	Weight in kg
(6-10)	52
(6-16)	54
(6-20)	56

Fresh water module TransTherm® aqua F (6-10 to 6-20)
(Dimensions in mm)

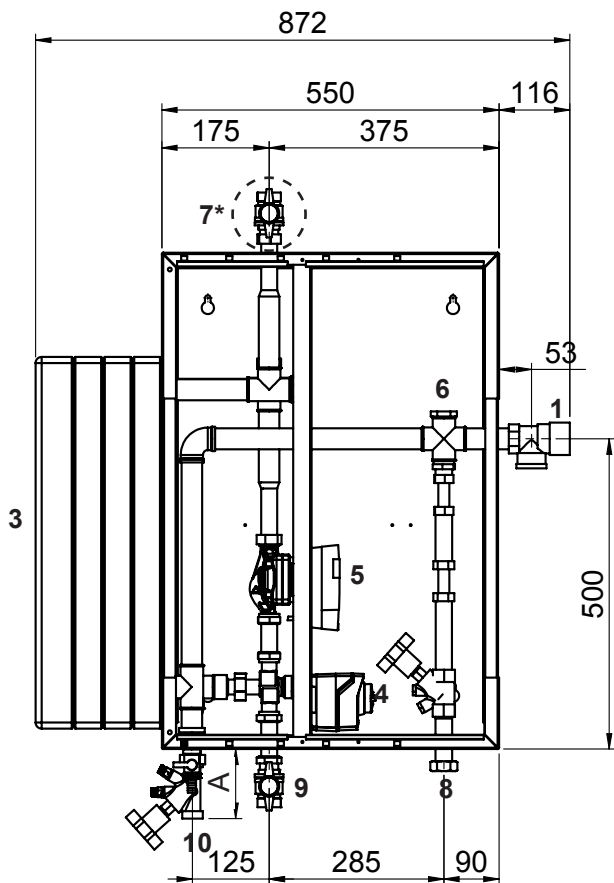

* For application according to the SVGW
The installation of ball valves is not permitted in Switzerland according to SVGW regulation W3.

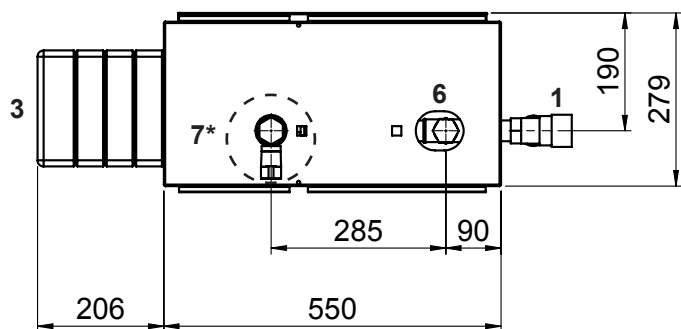
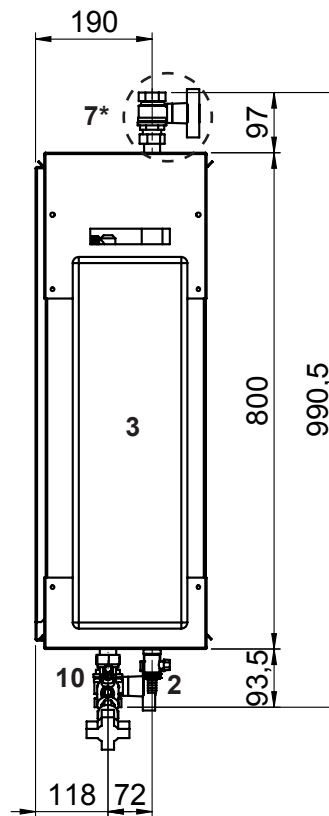

Version incl. circulation set

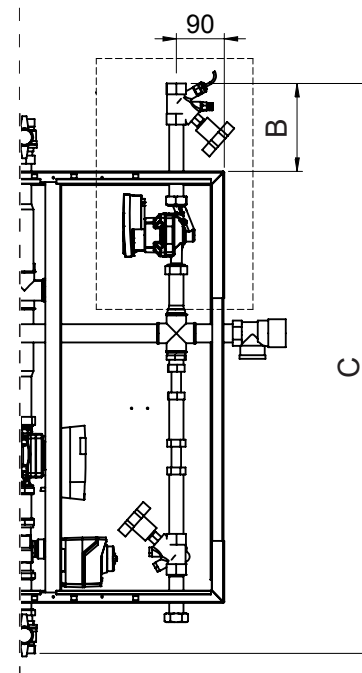

	A	B	C
(6-10)	112	163	1056
(6-16)	112	163	1045
(6-20)	133	246	1143

	(6-10)	(6-16)	(6-20)
1	Safety valve		
2	Hot water 10 bar		
3	Filling/drain valve		
4	Heat exchanger		
5	Primary three-way valve		
6	Primary circulating pump		
7*	Circulation ¹⁾	DN 25, Rp 1" (20, Rp ¾") (IT)	
8	Hot water	DN 25, Rp 1" (IT)	
9	Cold water	DN 25, Gp 1" (IT)	
10	Flow heating water	DN 25, Rp 1" (IT)	
	Return heating water	DN 20, Gp 1" (IT)	

¹⁾ Optional, connection and installation on site

Gp = straight internal thread

Fresh water module TransTherm® aqua F (6-30 to 6-50)
(Dimensions in mm)

*** For application according to the SVGW**
The installation of ball valves is not permitted in Switzerland according to SVGW regulation W3.

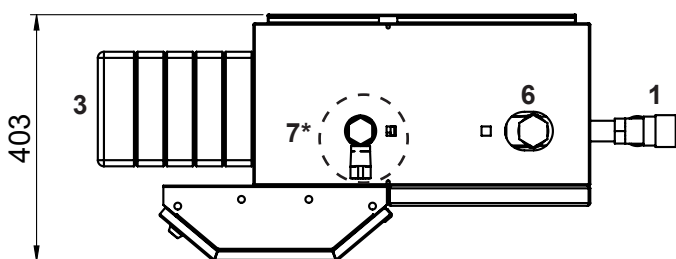
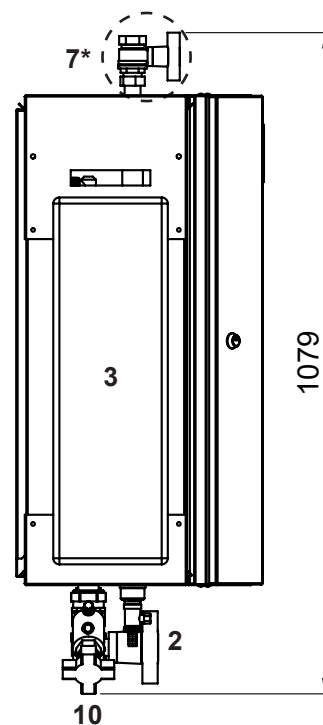
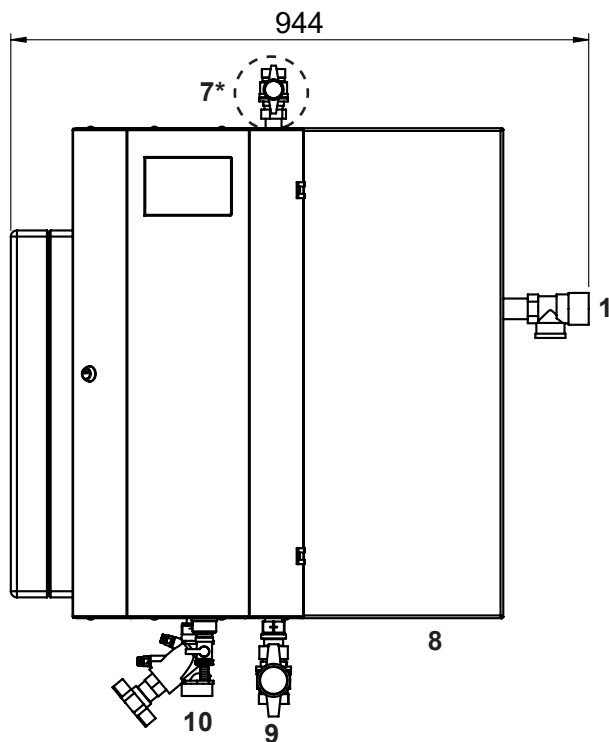

- 1 Safety valve
Hot water 10 bar
- 2 Filling/drain valve
- 3 Heat exchanger

(6-30) (6-40) (6-50)

- | | | |
|----|---------------------------|--|
| 6 | Circulation ¹⁾ | DN 32, Rp 1¼" (25 Rp 1") (20 Rp ¾") (IT) |
| 7* | Hot water | DN 32, Rp 1¼" (IT) |
| 8 | Cold water | DN 32, Rp 1¼" (IT) |
| 9 | Flow heating water | DN 32, Rp 1¼" (IT) |
| 10 | Return heating water | DN 32, Rp 1¼" (IT) |

¹⁾ Optional, connection and installation on site

TransTherm® aqua F Weight in kg

(6-30)	62
(6-40)	64
(6-50)	66

Fresh water module TransTherm® aqua F (6-30 to 6-50)
(Dimensions in mm)

* For application according to the SVGW
The installation of ball valves is not permitted in Switzerland according to SVGW regulation W3.

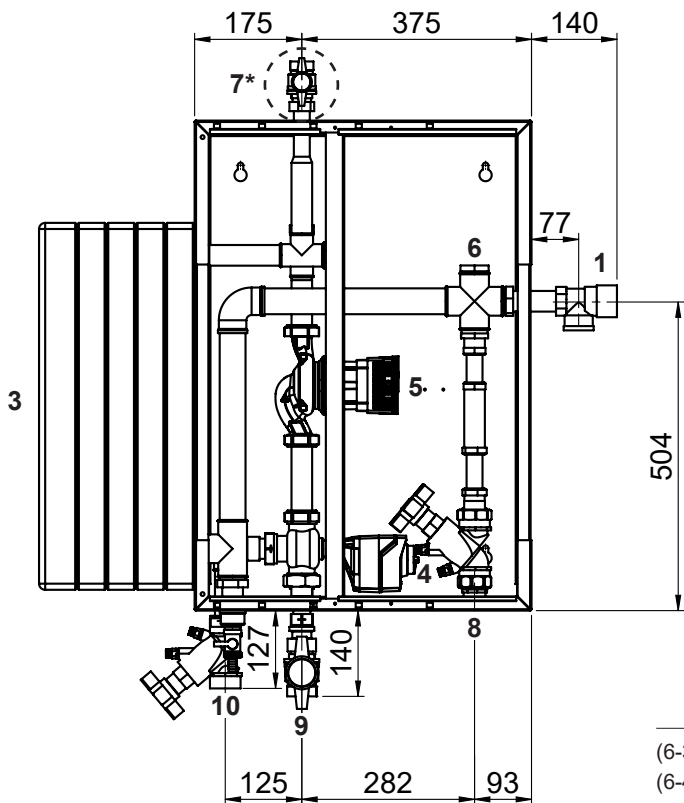

	A
(6-30), (6-50)	1074
(6-40)	1077

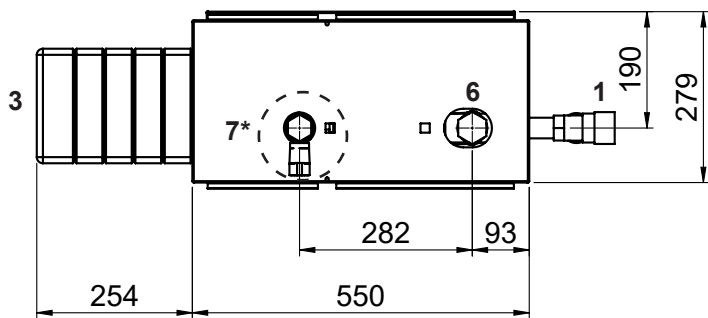
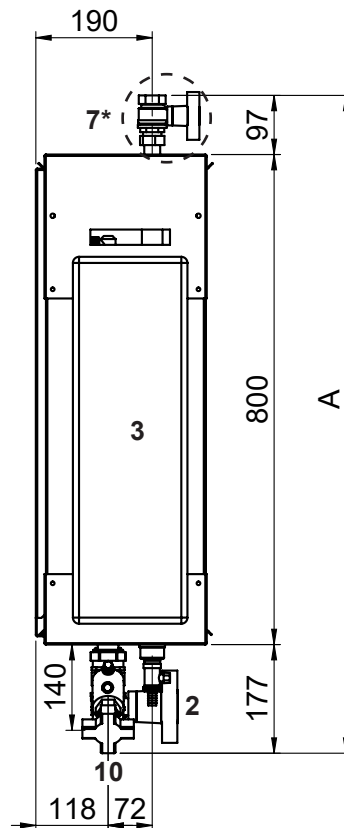

- 1 Safety valve
Hot water 10 bar
- 2 Filling/drain valve
- 3 Heat exchanger
- 4 Primary three-way valve
- 5 Primary circulating pump

(6-30) (6-40) (6-50)

- 6 Circulation ¹⁾ DN 32, Rp 1¼" (25 Rp 1") (20 Rp ¾") (IT)
- 7* Hot water DN 32, Rp 1¼" (IT)
- 8 Cold water DN 32, Rp 1¼" (IT)
- 9 Flow heating water DN 32, Rp 1¼" (IT)
- 10 Return heating water DN 32, Rp 1¼" (IT)

¹⁾ Optional, connection and installation on site

Version incl. circulation set

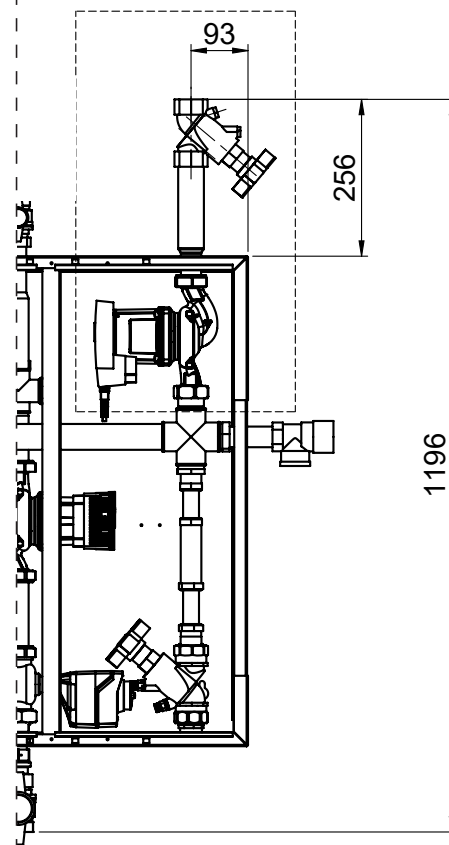

Water heating
TransTherm® aqua F

*** For application according to the SVGW**
The installation of ball valves is not permitted in Switzerland according to SVGW regulation W3.

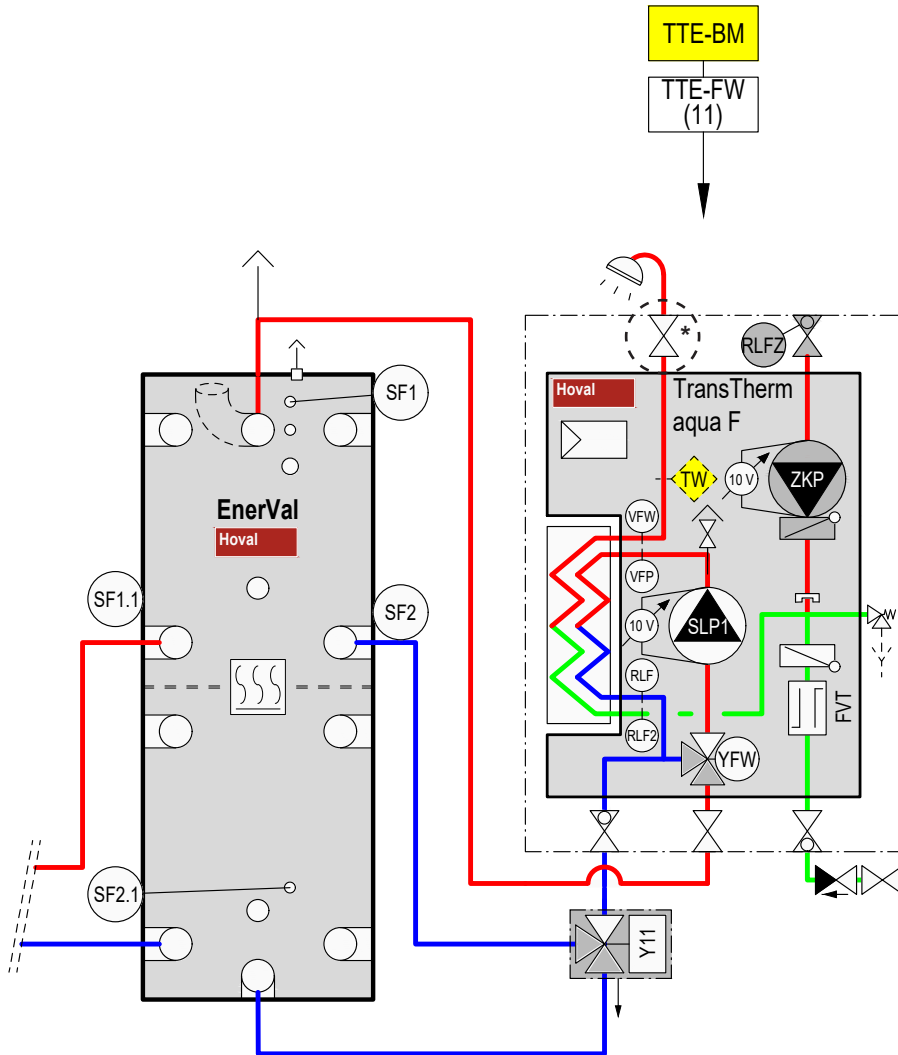

- TTE-FW Basic module district heating/fresh water
- TW Flow temperature monitor (if required)
- VFP Flow sensor primary
- VFW Flow sensor DHW
- RLF Return sensor primary
- RLF2 Return sensor domestic cold water
- SF Calorifier sensor
- SF1 Calorifier sensor 1
- RLFZ Circulation sensor
- SLP1 Calorifier charging pump primary
- FVT Flow rate sensor
- YFW Three-way valve with actuator
- ZKP Recirculation pump
- Y11 Return switching with actuator

Option

- BM TopTronic® E control module
- SF2 Calorifier sensor 2

Hoval quality.
You can count on us.

Hoval is one of the leading international companies for heating and indoor climate solutions. Drawing on more than 80 years of experience and benefiting from a close-knit team culture, the Hoval Group delivers exciting solutions and develops technically superior products. This leadership role requires a sense of responsibility for energy and the environment, which is expressed in an intelligent combination of different heating technologies and customised indoor climate solutions.

Hoval also provides personal consultations and comprehensive customer service. With around 2500 employees in 15 companies around the world, Hoval sees itself not as a conglomerate, but as a large family that thinks and acts globally.

Hoval heating and indoor climate solutions are currently exported to more than 50 countries.

Responsibility for energy and environment

Your Hoval partner

Liechtenstein

Hoval Aktiengesellschaft
9490 Vaduz
+423 399 24 00
hoval.com

United Kingdom

Hoval Ltd.
Newark Notts. NG 24 1JN
+44 1636 672 711
hoval.co.uk

Hoval TransTherm[®] aqua

Calorifier continuous flow system

TransTherm[®] aqua F (6-60)-(6-90)



Table of contents

■ Description	5
■ Part numbers	6
■ Technical data	10
■ Dimensions	19
■ Example	23

Calorifier continuous flow system

Consisting of:

- fresh water module TransTherm® aqua F
- buffer storage tank (option)

Fresh water module TransTherm® aqua F

- Fully installed station with plate heat exchanger for the provision of domestic hot water using the continuous flow principle
- Mounted on stand frame.
Stand frame consisting of:
 - frame with corrosion protection coating RAL 9005
 - height-adjustable and vibration-damped feet
- The primary side (heating side) contains the three-way valve, high-efficiency pump, ventilation, filling/drain valve and balancing valve. These components ensure a constant flow temperature at the plate heat exchanger. Pipes made from steel
- The secondary side (DHW side) contains the safety valve (10 bar), non-return valve and a filling/drain valve. A flow sensor ensures the correct hot water temperature. Pipes made from stainless steel
- Stainless steel plate heat exchanger 1.4404, copper-soldered
- Flow rate sensor
- T-piece with dummy plug for on-site connection of the circulation group. Connect the pump to the controller on site.
- TopTronic® E control with integrated thermal disinfection of the DHW storage tank (anti-legionella circuit)

Thermal insulation consisting of:

- thermal insulation of the heat exchanger with 30-mm EPP mouldings
- thermal insulation of the pipes with EPP mouldings. Insulation thickness of 50 % according to EnEV
- deep black, similar to RAL 9005
- suitable for damp rooms
- CFC-free
- normal flammability according to DIN 4102-1 and EN 13501-1 (fuel class: B2)
- no bleaching and disintegration of the insulation under the influence of UV light

Delivery

- The buffer storage tank required is not included in the scope of delivery

On site

- Installation of a circulation unit; the necessary connection is provided.
- Electrical connection of the controller

TopTronic® E controller

TopTronic® E basic module district heating/fresh water

- Control unit for controlling district heating transfer stations in non-communicative networks and the corresponding consumers with integrated control functions for
 - primary valve control
 - cascade management
 - 1 heating/cooling circuit with mixer
 - 1 heating/cooling circuit without mixer
 - 1 hot water charging circuit
 - various additional functions

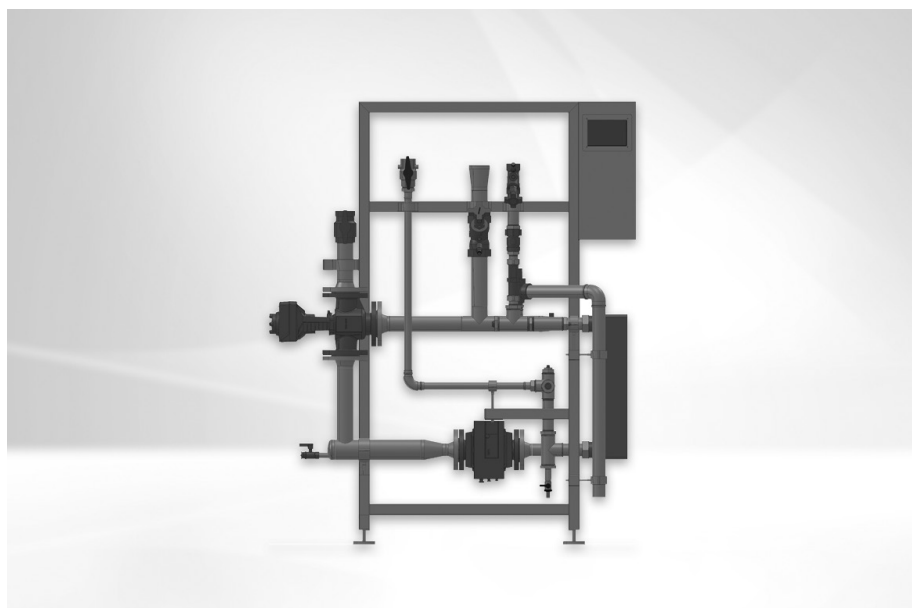

Range

Fresh water module

TransTherm® aqua F type	Output kW
(6-60)	350
(6-70)	450
(6-80)	580
(6-90)	700

- Various functions for hot water:
 - selection of different basic programs (week programs, economy mode, holiday until, etc.)
 - various operating modes (e.g. accumulator priority or parallel mode)
 - buffer storage circuit on the primary or secondary side
 - adjustable loading criteria (e.g.: adjustable loading times, undershooting the minimum nominal value, etc.)
 - adjustable switch-off criteria (e.g. achieving the setpoint valve, achieving the lower sensor setpoint value, etc.)
 - adjustable loading block (if the loading flow temperature is too low, the setpoint temperature is not reached, differential temperature-dependent solar circuit control)
- Definable switching times for recirculation pump control
- Outdoor sensor
- Immersion sensor (calorifier sensor)
- Contact sensor (flow temperature sensor)
- Complete plug set for DH module
- speed-controlled pumps

No further module expansions or controller modules can be installed in the control panel!

Option

TopTronic® E control module

- Simple, intuitive operating concept
- Display of the most important operating states
- Configurable start screen
- Operating mode selection

- Configurable day and week programs
- Operation of all connected Hoval CAN bus modules
- Commissioning wizard
- Service and maintenance function
- Fault message management
- Analysis function
- Weather display (with HovalConnect option)
- Adaptation of the heating strategy based on the weather forecast (with HovalConnect option)

Notice

The TopTronic® E control module for operating the basic module district heating/fresh water must be ordered separately!

Further information about the TopTronic® E see "Controls"

Delivery

- All armatures required for operation, such as strainers, flow balancing and shut-off valves, backflow preventer, air-bleeding and drain valve are fitted.

Caution

As a result of thermal disinfection of the domestic hot water for legionella protection, increased water temperatures (at least 65 ... 70 °C) occur. Depending on the water quality, this may result in increased calcification at the installed armatures and heat exchangers and also brings the risk of scalding at the tapping points. Corresponding protective measures must be implemented on site.

Hot water connection for application according to the SVGW (Swiss association for electricity, gas, district heating and water)

The installation of ball valves is not permitted in Switzerland according to SVGW regulation W3.

Fresh water module

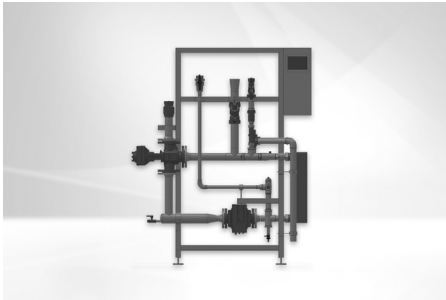

TransTherm® aqua F

Fully assembled station with plate heat exchanger for the provision of domestic hot water using the continuous flow principle and built-in Hoval TopTronic® E control
The required buffer storage tank is not supplied.

Authorisation number

TransTherm® aqua F (6-60)-(6-90)
SVGW test number 2407-7331

TransTherm® aqua F	Output kW	Part No.
(6-60)	350	8006 393
(6-70)	450	8006 394
(6-80)	580	8006 395
(6-90)	700	8006 396

Accessories

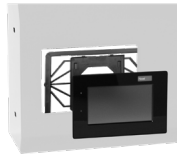

TopTronic® E control module black with 4.3" colour touchscreen

For operation of all controller modules connected to the bus system (basic, solar, buffer modules etc.)
 Connection to the Hoval bus system via RJ45 plug connection or via plug terminals (max. 0.75 mm²), flat design with flexible installation option

Installation:

- in control panel of the heat generator
- in the Hoval wall casing
- in the control panel front, black high-gloss cover, customer-specific configurable start screen,

Display of current weather or weather forecast (only possible in combination with HovalConnect)

Consisting of:

- TopTronic® E control module black
- Clamping device set control module
- RJ45-RAST 5 CAN cable, L = 500



Return changeover valve set

Consisting of:

- temperature sensor
- changeover valve
- drive (8 sec.) DN 20-40
- drive (30 sec.) DN 50-80
- seals
- screw connections

Nominal diameter	Output kW	k _{vs} m ³ /h
DN 20	50-90	6.3
DN 25	115-175	10
DN 32	230-275	16
DN 40	350	25
DN 50	450	40
DN 65	580	63
DN 80	700	100

6043 844

Notice

When using a circulation set (also on-site recirculation pump), it is imperative to install a return switching valve set.



Circulation set

for TransTherm® aqua L, L-FW, F
 Piping of parts in contact with domestic water in stainless steel and gunmetal

Consisting of:

- temperature sensor PT1000
- recirculation pump Wilo Yonos PARA
- recirculation pump Wilo Para MAXO
- regulating valve
- non-return valve

Connection	Flow rate m ³ /h	Recirculation pump
DN 20 ¾" Rp	1.9	Z15/7.0 RKC
DN 25 1" Rp	3.4	Z25/180/08/F02
DN 32 1¼" Rp	5.8	Z25/180/08/F02

8005 279

8005 280

8005 281

Part No.



Test valve DN 8 G 1/4"
 for TransTherm® aqua L, L-FW, F, FS
 Test valve suitable for flame treatment
 for hygienic-microbiologic
 tests.

2049 861



Sludge separator DM with magnet
 made of technopolymer (PO) or
 brass with insulation (MS)

Type	Connection inches	Flow rate at 1.2 m/s flow speed m³/h	k _v value m³/h
DM PO	Rp 1"	1.3	10.5
DM PO	Rp 1 1/4"	2.1	10.5
DM MS	Rp 1 1/2"	5.4	63.2
DM MS	Rp 2"	8.2	70.0

2054 376
 2085 523
 2085 527
 2085 528

Additional sludge separators
 see "Various system components"



**Insulation for sludge separator
 DM PO 1"**
 10 mm insulating caps made of PE-X foam
 Thermal conductivity 0.035 W/mK
 Fire resistance (DIN 4102): class B2

2085 524



**Insulation for sludge separator
 DM PO 1 1/4"**
 10 mm insulating caps made of PE-X foam
 Thermal conductivity 0.035 W/mK
 Fire resistance (DIN 4102): class B2

2086 031

Part No.



Temperature monitor 0 ... 120 °C
for TransTherm® aqua L, L-FW, F, FS

2048 299



Safety temperature monitor 70 ... 130 °C
for TransTherm® aqua L, L-FW, F, FS

2048 300



Safety temperature limiter 70 ... 130 °C
for TransTherm® aqua L, L-FW, F, FS

2049 619



Immersion sleeve G 1/2" stainless steel for thermostat
for TransTherm® aqua L, L-FW, F, FS
Installation length = 100 mm
Outer Ø: 8 mm, inner Ø: 6.5 mm

2048 285



Immersion sleeve G 1/2" stainless steel for 2 thermostats
for TransTherm® aqua L, L-FW, F, FS
Installation length = 100 mm
Outer Ø: 15 mm, inner Ø: 13.5 mm

2048 288

Services



Services and associated scope of services
see separate catalogue "Hoval Services"

Commissioning by Hoval customer service is a prerequisite for warranty/guarantee activation.

Performance data

TransTherm® aqua F (6-60 to 6-90)

Domestic water secondary			Flow temperature heating water											
			52 °C				55 °C				60 °C			
			(60)	(70)	(80)	(90)	(60)	(70)	(80)	(90)	(60)	(70)	(80)	(90)
60/5 °C	T return primary	°C	-	-	-	-	-	-	-	-	-	-	-	-
	Ṽ primary	m³/h	-	-	-	-	-	-	-	-	-	-	-	-
	Q max.	kW	-	-	-	-	-	-	-	-	-	-	-	-
	Ṽ secondary	m³/h	-	-	-	-	-	-	-	-	-	-	-	-
60/10 °C	T return primary	°C	-	-	-	-	-	-	-	-	-	-	-	-
	Ṽ primary	m³/h	-	-	-	-	-	-	-	-	-	-	-	-
	Q max.	kW	-	-	-	-	-	-	-	-	-	-	-	-
	Ṽ secondary	m³/h	-	-	-	-	-	-	-	-	-	-	-	-
60/15 °C	T return primary	°C	-	-	-	-	-	-	-	-	-	-	-	-
	Ṽ primary	m³/h	-	-	-	-	-	-	-	-	-	-	-	-
	Q max.	kW	-	-	-	-	-	-	-	-	-	-	-	-
	Ṽ secondary	m³/h	-	-	-	-	-	-	-	-	-	-	-	-
60/20 °C	T return primary	°C	-	-	-	-	-	-	-	-	-	-	-	-
	Ṽ primary	m³/h	-	-	-	-	-	-	-	-	-	-	-	-
	Q max.	kW	-	-	-	-	-	-	-	-	-	-	-	-
	Ṽ secondary	m³/h	-	-	-	-	-	-	-	-	-	-	-	-
55/5 °C	T return primary	°C	-	-	-	-	-	-	-	-	28	28	28	27
	Ṽ primary	m³/h	-	-	-	-	-	-	-	-	7.27	10.06	12.62	15.81
	Q max.	kW	-	-	-	-	-	-	-	-	270	370	470	600
	Ṽ secondary	m³/h	-	-	-	-	-	-	-	-	4.68	6.42	8.15	10.4
55/10 °C	T return primary	°C	-	-	-	-	-	-	-	-	30	29	29	29
	Ṽ primary	m³/h	-	-	-	-	-	-	-	-	7.30	9.04	11.82	14.63
	Q max.	kW	-	-	-	-	-	-	-	-	255	320	420	530
	Ṽ secondary	m³/h	-	-	-	-	-	-	-	-	4.91	6.17	8.09	10.21
55/15 °C	T return primary	°C	-	-	-	-	-	-	-	-	30	30	30	30
	Ṽ primary	m³/h	-	-	-	-	-	-	-	-	5.20	7.23	9.25	13.01
	Q max.	kW	-	-	-	-	-	-	-	-	180	250	320	450
	Ṽ secondary	m³/h	-	-	-	-	-	-	-	-	3.90	5.42	6.94	9.75
55/20 °C	T return primary	°C	-	-	-	-	-	-	-	-	30	30	30	30
	Ṽ primary	m³/h	-	-	-	-	-	-	-	-	3.18	4.34	5.78	7.51
	Q max.	kW	-	-	-	-	-	-	-	-	110	150	200	260
	Ṽ secondary	m³/h	-	-	-	-	-	-	-	-	2.73	3.72	4.95	6.44
50/5 °C	T return primary	°C	-	-	-	-	25	25	25	24	22	22	21	21
	Ṽ primary	m³/h	-	-	-	-	7.32	8.93	11.59	14.69	7.17	9.14	11.65	13.93
	Q max.	kW	-	-	-	-	250	310	405	520	315	405	520	630
	Ṽ secondary	m³/h	-	-	-	-	4.82	5.97	7.80	10.02	6.07	7.80	10.02	12.14
50/10 °C	T return primary	°C	-	-	-	-	27	27	27	26	24	24	24	23
	Ṽ primary	m³/h	-	-	-	-	7.17	8.95	11.64	14.45	6.78	8.62	11.52	13.16
	Q max.	kW	-	-	-	-	230	290	380	480	280	360	485	560
	Ṽ secondary	m³/h	-	-	-	-	4.99	6.29	8.24	10.4	6.07	7.80	10.51	12.14
50/15 °C	T return primary	°C	-	-	-	-	29	29	29	28	26	26	26	26
	Ṽ primary	m³/h	-	-	-	-	7.25	9.24	11.63	14.5	6.31	8.10	10.97	12.35
	Q max.	kW	-	-	-	-	215	275	350	445	245	315	430	490
	Ṽ secondary	m³/h	-	-	-	-	5.33	6.81	8.67	11.02	6.07	7.80	10.65	12.14
50/20 °C	T return primary	°C	-	-	-	-	30	30	30	30	30	29	29	29
	Ṽ primary	m³/h	-	-	-	-	5.03	6.59	9.02	11.96	6.00	7.6	10.35	11.6
	Q max.	kW	-	-	-	-	145	190	260	345	210	270	370	420
	Ṽ secondary	m³/h	-	-	-	-	4.20	5.49	7.51	9.97	6.07	7.80	10.69	12.14
45/5 °C	T return primary	°C	21	21	21	20	20	19	19	19	18	18	18	17
	Ṽ primary	m³/h	7.20	8.95	11.53	14.54	6.90	8.77	11.62	13.4	5.77	7.36	10.00	11.26
	Q max.	kW	255	320	415	530	280	360	480	560	280	360	490	560
	Ṽ secondary	m³/h	5.53	6.94	9.00	11.50	6.07	7.80	10.4	12.14	6.07	7.80	10.62	12.14
45/10 °C	T return primary	°C	23	23	23	23	22	22	22	21	20	20	20	19
	Ṽ primary	m³/h	7.12	9.21	11.51	14.45	6.44	8.23	11.13	12.57	5.27	6.77	9.24	10.28
	Q max.	kW	235	305	385	490	245	315	430	490	245	315	430	490
	Ṽ secondary	m³/h	5.82	7.56	9.54	12.14	6.07	7.80	10.65	12.14	6.07	7.80	10.65	12.14
45/15 °C	T return primary	°C	25	25	25	25	25	24	24	24	23	22	22	22
	Ṽ primary	m³/h	6.10	8.03	10.67	13.49	6.01	7.63	10.38	11.63	4.88	6.23	8.51	9.53
	Q max.	kW	190	250	335	420	210	270	370	420	210	270	370	420
	Ṽ secondary	m³/h	5.49	7.23	9.68	12.14	6.07	7.80	10.69	12.14	6.07	7.80	10.69	12.14
45/20 °C	T return primary	°C	25	25	25	25	27	27	27	27	25	25	25	25
	Ṽ primary	m³/h	2.73	3.53	4.66	6.42	5.46	6.97	9.57	10.65	4.37	5.59	7.68	8.57
	Q max.	kW	85	110	145	200	175	225	310	350	175	225	310	350
	Ṽ secondary	m³/h	2.95	3.82	5.03	6.94	6.07	7.80	10.75	12.14	6.07	7.80	10.75	12.14

T return primary °C Return temperature primary
Ṽ primary m³/h Flow rate primary
 Q max. kW Output
Ṽ secondary m³/h Flow rate secondary

The specified technical data relate to the full load of the module in each case.

Performance data

TransTherm® aqua F (6-60 to 6-90)

Flow temperature heating water

Domestic water TransTherm® aqua F secondary			65 °C				70 °C			
			(60)	(70)	(80)	(90)	(60)	(70)	(80)	(90)
60/5 °C	T return primary	°C	30	30	30	29	26	26	25	25
	Ṽ primary	m³/h	7.15	9.17	11.72	14.69	7.42	9.40	11.66	14.64
	Q max.	kW	290	370	480	610	375	480	600	760
	Ṽ secondary	m³/h	4.57	5.83	7.57	9.62	5.91	7.57	9.46	11.98
60/10 °C	T return primary	°C	30	30	30	30	28	28	28	27
	Ṽ primary	m³/h	5.45	6.94	9.41	12.88	7.23	9.29	11.92	14.15
	Q max.	kW	220	280	380	520	350	450	580	700
	Ṽ secondary	m³/h	3.82	4.86	6.59	9.02	6.07	7.80	10.06	12.14
60/15 °C	T return primary	°C	30	30	30	30	30	30	30	30
	Ṽ primary	m³/h	3.72	4.83	6.44	8.67	6.72	8.78	11.73	13.49
	Q max.	kW	150	195	260	350	310	405	540	630
	Ṽ secondary	m³/h	2.89	3.76	5.01	6.74	5.97	7.80	10.4	12.14
60/20 °C	T return primary	°C	30	30	30	30	30	30	30	30
	Ṽ primary	m³/h	2.11	2.85	3.72	4.95	4.34	5.64	7.37	9.97
	Q max.	kW	85	115	150	200	200	260	340	460
	Ṽ secondary	m³/h	1.84	2.49	3.25	4.34	4.34	5.64	7.37	9.97
55/5 °C	T return primary	°C	24	24	23	23	22	21	21	21
	Ṽ primary	m³/h	7.42	9.24	11.64	14.38	6.30	8.03	10.99	12.26
	Q max.	kW	350	440	560	700	350	450	620	700
	Ṽ secondary	m³/h	6.07	7.63	9.71	12.14	6.07	7.80	10.75	12.14
55/10 °C	T return primary	°C	26	26	26	25	24	24	24	23
	Ṽ primary	m³/h	7.06	8.96	11.66	13.66	5.96	7.6	10.25	11.6
	Q max.	kW	315	405	530	630	315	405	550	630
	Ṽ secondary	m³/h	6.07	7.80	10.21	12.14	6.07	7.80	10.6	12.14
55/15 °C	T return primary	°C	29	28	28	27	27	26	26	26
	Ṽ primary	m³/h	6.67	8.48	11.48	12.91	5.62	7.16	9.70	10.96
	Q max.	kW	280	360	490	560	280	360	490	560
	Ṽ secondary	m³/h	6.07	7.80	10.62	12.14	6.07	7.80	10.62	12.14
55/20 °C	T return primary	°C	30	30	30	30	29	29	29	28
	Ṽ primary	m³/h	5.95	7.80	10.4	12.14	5.13	6.64	9.01	10.16
	Q max.	kW	240	315	420	490	245	315	430	490
	Ṽ secondary	m³/h	5.95	7.80	10.4	12.14	6.07	7.80	10.65	12.14
50/5 °C	T return primary	°C	20	20	19	19	18	18	17	17
	Ṽ primary	m³/h	6.06	7.72	10.43	11.77	5.30	6.74	9.05	10.27
	Q max.	kW	315	405	550	630	315	405	550	630
	Ṽ secondary	m³/h	6.07	7.80	10.6	12.14	6.07	7.80	10.6	12.14
50/10 °C	T return primary	°C	22	22	22	21	21	20	20	19
	Ṽ primary	m³/h	5.69	7.28	9.81	11.08	4.90	6.24	8.46	9.57
	Q max.	kW	280	360	490	560	280	360	490	560
	Ṽ secondary	m³/h	6.07	7.80	10.62	12.14	6.07	7.80	10.62	12.14
50/15 °C	T return primary	°C	25	25	24	24	23	23	22	22
	Ṽ primary	m³/h	5.30	6.74	9.14	10.29	4.52	5.76	7.82	8.83
	Q max.	kW	245	315	430	490	245	315	430	490
	Ṽ secondary	m³/h	6.07	7.80	10.65	12.14	6.07	7.80	10.65	12.14
50/20 °C	T return primary	°C	27	26	27	26	26	26	25	25
	Ṽ primary	m³/h	4.84	6.00	8.38	9.43	4.12	5.26	7.16	8.07
	Q max.	kW	210	270	370	420	210	270	370	420
	Ṽ secondary	m³/h	6.07	7.80	10.69	12.14	6.07	7.80	10.69	12.14
45/5 °C	T return primary	°C	16	16	16	15	15	14	14	13
	Ṽ primary	m³/h	4.99	6.34	8.58	9.69	4.39	5.59	7.59	8.58
	Q max.	kW	280	360	490	560	280	360	490	560
	Ṽ secondary	m³/h	6.07	7.80	10.62	12.14	6.07	7.80	10.62	12.14
45/10 °C	T return primary	°C	19	18	18	18	17	17	17	16
	Ṽ primary	m³/h	4.57	5.85	7.92	8.94	4.02	5.13	6.98	7.90
	Q max.	kW	245	315	430	490	245	315	430	490
	Ṽ secondary	m³/h	6.07	7.80	10.65	12.14	6.07	7.80	10.65	12.14
45/15 °C	T return primary	°C	21	21	21	20	20	20	20	19
	Ṽ primary	m³/h	4.15	5.30	7.24	8.15	3.64	4.66	6.37	7.18
	Q max.	kW	210	270	370	420	210	270	370	420
	Ṽ secondary	m³/h	6.07	7.80	10.69	12.14	6.07	7.80	10.69	12.14
45/20 °C	T return primary	°C	24	24	24	24	23	23	23	23
	Ṽ primary	m³/h	3.71	4.75	6.51	7.31	3.24	4.15	5.71	6.42
	Q max.	kW	175	225	310	350	175	225	310	350
	Ṽ secondary	m³/h	6.07	7.80	10.75	12.14	6.07	7.80	10.75	12.14

T return primary °C Return temperature primary
Ṽ primary m³/h Flow rate primary
 Q max. kW Output
Ṽ secondary m³/h Flow rate secondary

The specified technical data relate to the full load of the module in each case.

Performance data

TransTherm® aqua F

Residential units standard apartment according to DIN 4708	Peak heat demand standard apartment according to DIN 4708 with preparation 10 min	Sum flow rate domestic hot water calculation flow rate according to DIN 4708	Simultaneity factor according to DIN 4708	Peak flow rate (DHW)	Peak flow rate (DHW)	Peak flow rate (DHW)	Peak output (DHW)	Peak flow rate TransTherm® aqua F (DHW)	Peak flow rate TransTherm® aqua F (DHW)	Peak flow rate TransTherm® aqua F (DHW)	DHW calorifier output TransTherm® aqua F	TransTherm® aqua F	Required heating water volume at 70/30 °C (40 K)	Required heating water buffer storage tank volume at 70/30 °C (40 K)	Buffer storage tank 1 EnerVal	Required recharging capacity	Required recharging capacity	Required recharging capacity
	[Wh]	[l/s]		[l/s]	[l/min]	[m³/h]	[kW]	[l/s]	[l/min]	[m³/h]	[kW]		[m³]	[m³]		[kW]	[kW]	[kW]
1	5820	0.17	1.00	0.17	10.01	0.60	35	0.24	14.3	0.86	50	(6-10)	0.13	0.16	(200)	23	15	8
2	11640	0.33	0.680	0.23	13.61	0.82	47	0.24	14.3	0.86	50	(6-10)	0.17	0.22	(200)	31	21	10
3	17460	0.50	0.544	0.27	16.33	0.98	57	0.43	25.8	1.55	90	(6-16)	0.20	0.27	(300)	37	25	12
4	23280	0.67	0.466	0.31	18.66	1.12	65	0.43	25.8	1.55	90	(6-16)	0.23	0.30	(300)	42	28	14
5	29100	0.83	0.415	0.35	20.77	1.25	72	0.43	25.8	1.55	90	(6-16)	0.26	0.34	(500)	47	31	16
6	34920	1.00	0.377	0.38	22.64	1.36	79	0.43	25.8	1.55	90	(6-16)	0.28	0.37	(500)	51	34	17
7	40740	1.17	0.349	0.41	24.45	1.47	85	0.43	25.8	1.55	90	(6-16)	0.31	0.40	(500)	55	37	18
8	46560	1.33	0.349	0.47	27.94	1.68	97	0.55	33.0	1.98	115	(6-20)	0.35	0.45	(500)	63	42	21
9	52380	1.50	0.308	0.46	27.74	1.66	97	0.55	33.0	1.98	115	(6-20)	0.35	0.45	(500)	63	42	21
10	58200	1.67	0.292	0.49	29.23	1.75	102	0.55	33.0	1.98	115	(6-20)	0.37	0.47	(500)	66	44	22
11	64020	1.83	0.279	0.51	30.72	1.84	107	0.55	33.0	1.98	115	(6-20)	0.38	0.50	(500)	70	46	23
12	69840	2.00	0.268	0.54	32.19	1.93	112	0.55	33.0	1.98	115	(6-20)	0.40	0.52	(500)	73	49	24
13	75660	2.17	0.258	0.56	33.57	2.01	117	0.55	33.0	1.98	115	(6-20)	0.42	0.55	(500)	76	51	25
14	81480	2.34	0.249	0.58	34.89	2.09	122	0.84	50.2	3.01	175	(6-30)	0.44	0.57	(500)	79	53	26
15	87300	2.50	0.242	0.61	36.33	2.18	127	0.84	50.2	3.01	175	(6-30)	0.45	0.59	(800)	82	55	27
16	93120	2.67	0.235	0.63	37.63	2.26	131	0.84	50.2	3.01	175	(6-30)	0.47	0.61	(800)	85	57	28
17	98940	2.84	0.228	0.65	38.79	2.33	135	0.84	50.2	3.01	175	(6-30)	0.49	0.63	(800)	88	59	29
18	104760	3.00	0.223	0.67	40.17	2.41	140	0.84	50.2	3.01	175	(6-30)	0.50	0.65	(800)	91	61	30
19	110580	3.17	0.217	0.69	41.27	2.48	144	0.84	50.2	3.01	175	(6-30)	0.52	0.67	(800)	94	62	31
20	116400	3.34	0.212	0.71	42.44	2.55	148	0.84	50.2	3.01	175	(6-30)	0.53	0.69	(800)	96	64	32
21	122220	3.50	0.208	0.73	43.72	2.62	153	0.84	50.2	3.01	175	(6-30)	0.55	0.71	(800)	99	66	33
22	128040	3.67	0.204	0.75	44.92	2.70	157	0.84	50.2	3.01	175	(6-30)	0.56	0.73	(800)	102	68	34
23	133860	3.84	0.200	0.77	46.04	2.76	161	0.84	50.2	3.01	175	(6-30)	0.58	0.75	(800)	104	70	35
24	139680	4.00	0.196	0.78	47.08	2.82	164	0.84	50.2	3.01	175	(6-30)	0.59	0.77	(800)	107	71	36
25	145500	4.17	0.193	0.80	48.29	2.90	168	0.84	50.2	3.01	175	(6-30)	0.60	0.78	(800)	110	73	37
26	151320	4.34	0.190	0.82	49.44	2.97	173	0.84	50.2	3.01	175	(6-30)	0.62	0.80	(800)	112	75	37
27	157140	4.50	0.187	0.84	50.53	3.03	176	0.84	50.2	3.01	175	(6-30)	0.63	0.82	(800)	115	76	38
28	162960	4.67	0.184	0.86	51.56	3.09	180	0.84	50.2	3.01	175	(6-30)	0.64	0.84	(800)	117	78	39
29	168780	4.84	0.181	0.88	52.54	3.15	183	1.10	65.8	3.95	230	(6-40)	0.66	0.85	(800)	119	79	40
30	174600	5.00	0.179	0.90	53.75	3.22	188	1.10	65.8	3.95	230	(6-40)	0.67	0.87	(1000)	122	81	41
31	180420	5.17	0.176	0.91	54.61	3.28	191	1.10	65.8	3.95	230	(6-40)	0.68	0.89	(1000)	124	83	41
32	186240	5.34	0.174	0.93	55.73	3.34	194	1.10	65.8	3.95	230	(6-40)	0.70	0.91	(1000)	126	84	42
33	192060	5.50	0.172	0.95	56.81	3.41	198	1.10	65.8	3.95	230	(6-40)	0.71	0.92	(1000)	129	86	43
34	197880	5.67	0.170	0.96	57.85	3.47	202	1.10	65.8	3.95	230	(6-40)	0.72	0.94	(1000)	131	87	44
35	203700	5.84	0.168	0.98	58.85	3.53	205	1.10	65.8	3.95	230	(6-40)	0.74	0.96	(1000)	133	89	44
36	209520	6.01	0.166	1.00	59.81	3.59	209	1.10	65.8	3.95	230	(6-40)	0.75	0.97	(1000)	136	90	45
37	215340	6.17	0.164	1.01	60.73	3.64	212	1.10	65.8	3.95	230	(6-40)	0.76	0.99	(1000)	138	92	46
38	221160	6.34	0.163	1.03	61.99	3.72	216	1.10	65.8	3.95	230	(6-40)	0.78	1.01	(1000)	141	94	47
39	226980	6.51	0.161	1.05	62.84	3.77	219	1.10	65.8	3.95	230	(6-40)	0.79	1.02	(1000)	143	95	48
40	232800	6.67	0.159	1.06	63.65	3.82	222	1.10	65.8	3.95	230	(6-40)	0.80	1.03	(1000)	144	96	48
41	238620	6.84	0.158	1.08	64.84	3.89	226	1.10	65.8	3.95	230	(6-40)	0.81	1.05	(1000)	147	98	49
42	244440	7.01	0.156	1.09	65.58	3.93	229	1.10	65.8	3.95	230	(6-40)	0.82	1.07	(1000)	149	99	50
43	250260	7.17	0.155	1.11	66.71	4.00	233	1.10	65.8	3.95	230	(6-40)	0.83	1.08	(1000)	151	101	50
44	256080	7.34	0.154	1.13	67.82	4.07	237	1.31	78.8	4.73	275	(6-50)	0.85	1.10	(1500)	154	103	51
45	261900	7.51	0.152	1.14	68.46	4.11	239	1.31	78.8	4.73	275	(6-50)	0.86	1.11	(1500)	155	104	52
46	267720	7.67	0.151	1.16	69.52	4.17	243	1.31	78.8	4.73	275	(6-50)	0.87	1.13	(1500)	158	105	53
47	273540	7.84	0.150	1.18	70.56	4.23	246	1.31	78.8	4.73	275	(6-50)	0.88	1.15	(1500)	160	107	53
48	279360	8.01	0.149	1.19	71.58	4.29	250	1.31	78.8	4.73	275	(6-50)	0.89	1.16	(1500)	162	108	54
49	285180	8.17	0.148	1.21	72.58	4.35	253	1.31	78.8	4.73	275	(6-50)	0.91	1.18	(1500)	165	110	55
50	291000	8.34	0.146	1.22	73.06	4.38	255	1.31	78.8	4.73	275	(6-50)	0.91	1.19	(1500)	166	110	55
51	296820	8.51	0.145	1.23	74.01	4.44	258	1.31	78.8	4.73	275	(6-50)	0.93	1.20	(1500)	168	112	56
52	302640	8.67	0.144	1.25	74.94	4.50	261	1.31	78.8	4.73	275	(6-50)	0.94	1.22	(1500)	170	113	57
53	308460	8.84	0.143	1.26	75.86	4.55	265	1.31	78.8	4.73	275	(6-50)	0.95	1.23	(1500)	172	115	57
54	314280	9.01	0.142	1.28	76.75	4.60	268	1.31	78.8	4.73	275	(6-50)	0.96	1.25	(1500)	174	116	58

Residential units standard apartment according to DIN 4708	Peak heat demand standard apartment according to DIN 4708 with preparation 10 min	Sum flow rate domestic hot water calculation flow rate according to DIN 4708	Simultaneity factor according to DIN 4708	Peak flow rate (DHW)	Peak flow rate (DHW)	Peak flow rate (DHW)	Peak output (DHW)	Peak flow rate TransTherm® aqua F (DHW)	Peak flow rate TransTherm® aqua F (DHW)	Peak flow rate TransTherm® aqua F (DHW)	DHW calorifier output TransTherm® aqua F	TransTherm® aqua F	Required heating water volume at 70/30 °C (40 K)	Required heating water buffer storage tank volume at 70/30 °C (40 K)	Buffer storage tank 1 EnerVal	Required recharging capacity	Required recharging capacity	Required recharging capacity
N	Preparation	∑ VR at DHW 60 °C	g	\dot{V}_s at DHW 60 °C	\dot{V}_s at DHW 60 °C	\dot{V}_s at DHW 60 °C		\dot{V}_s at DHW 60 °C	\dot{V}_s at DHW 60 °C	\dot{V}_s at DHW 60 °C	Q at HT 70/30 °C DHW 10/60 °C	Type			Type	Time: 20 min 70/30 °C (40 K)	Time: 30 min 70/30 °C (40 K)	Time: 60 min 70/30 °C (40 K)
	[Wh]	[l/s]		[l/s]	[l/min]	[m³/h]	[kW]	[l/s]	[l/min]	[m³/h]	[kW]		[m³]	[m³]		[kW]	[kW]	[kW]
55	320 100	9.17	0.141	1.29	77.62	4.66	271	1.31	78.8	4.73	275	(6-50)	0.97	1.26	(1500)	176	117	59
56	325 920	9.34	0.140	1.31	78.47	4.71	274	1.31	78.8	4.73	275	(6-50)	0.98	1.28	(1500)	178	119	59
57	331 740	9.51	0.140	1.33	79.87	4.79	279	1.31	78.8	4.73	275	(6-50)	1.00	1.30	(1500)	181	121	60
58	337 560	9.67	0.139	1.34	80.69	4.84	282	1.69	101.2	6.07	350	(6-60)	1.01	1.31	(1500)	183	122	61
59	343 380	9.84	0.138	1.36	81.49	4.89	284	1.69	101.2	6.07	350	(6-60)	1.02	1.32	(1500)	185	123	62
60	349 200	10.01	0.137	1.37	82.27	4.94	287	1.69	101.2	6.07	350	(6-60)	1.03	1.34	(1500)	187	124	62
61	355 020	10.18	0.136	1.38	83.03	4.98	290	1.69	101.2	6.07	350	(6-60)	1.04	1.35	(1500)	188	126	63
62	360 840	10.34	0.135	1.40	83.77	5.03	292	1.69	101.2	6.07	350	(6-60)	1.05	1.36	(1500)	190	127	63
63	366 660	10.51	0.135	1.42	85.12	5.11	297	1.69	101.2	6.07	350	(6-60)	1.06	1.38	(1500)	193	129	64
64	372 480	10.68	0.134	1.43	85.83	5.15	299	1.69	101.2	6.07	350	(6-60)	1.07	1.40	(1500)	195	130	65
65	378 300	10.84	0.133	1.44	86.52	5.19	302	1.69	101.2	6.07	350	(6-60)	1.08	1.41	(1500)	196	131	65
66	384 120	11.01	0.132	1.45	87.19	5.23	304	1.69	101.2	6.07	350	(6-60)	1.09	1.42	(1500)	198	132	66
67	389 940	11.18	0.132	1.48	88.52	5.31	309	1.69	101.2	6.07	350	(6-60)	1.11	1.44	(1500)	201	134	67
68	395 760	11.34	0.131	1.49	89.16	5.35	311	1.69	101.2	6.07	350	(6-60)	1.11	1.45	(1500)	202	135	67
69	401 580	11.51	0.130	1.50	89.78	5.39	313	1.69	101.2	6.07	350	(6-60)	1.12	1.46	(1500)	204	136	68
70	407 400	11.68	0.130	1.52	91.08	5.46	318	1.69	101.2	6.07	350	(6-60)	1.14	1.48	(1500)	207	138	69
71	413 220	11.84	0.129	1.53	91.67	5.50	320	1.69	101.2	6.07	350	(6-60)	1.15	1.49	(1500)	208	139	69
72	419 040	12.01	0.128	1.54	92.24	5.53	322	1.69	101.2	6.07	350	(6-60)	1.15	1.50	(1500)	209	139	70
73	424 860	12.18	0.128	1.56	93.52	5.61	326	1.69	101.2	6.07	350	(6-60)	1.17	1.52	(1500)	212	141	71
74	430 680	12.34	0.127	1.57	94.06	5.64	328	1.69	101.2	6.07	350	(6-60)	1.18	1.53	(1500)	213	142	71
75	436 500	12.51	0.127	1.59	95.33	5.72	333	1.69	101.2	6.07	350	(6-60)	1.19	1.55	(1500)	216	144	72
76	442 320	12.68	0.126	1.60	95.84	5.75	334	1.69	101.2	6.07	350	(6-60)	1.20	1.56	(1500)	217	145	72
77	448 140	12.84	0.126	1.62	97.10	5.83	339	1.69	101.2	6.07	350	(6-60)	1.21	1.58	(1500)	220	147	73
78	453 960	13.01	0.125	1.63	97.58	5.86	340	1.69	101.2	6.07	350	(6-60)	1.22	1.59	(1500)	221	148	74
79	459 780	13.18	0.124	1.63	98.04	5.88	342	1.69	101.2	6.07	350	(6-60)	1.23	1.59	(1500)	222	148	74
80	465 600	13.34	0.124	1.65	99.29	5.96	346	1.69	101.2	6.07	350	(6-60)	1.24	1.61	(2000)	225	150	75
81	471 420	13.51	0.123	1.66	99.72	5.98	348	1.69	101.2	6.07	350	(6-60)	1.25	1.62	(2000)	226	151	75
82	477 240	13.68	0.123	1.68	100.95	6.06	352	1.69	101.2	6.07	350	(6-60)	1.26	1.64	(2000)	229	153	76
83	483 060	13.85	0.122	1.69	101.35	6.08	354	1.69	101.2	6.07	350	(6-60)	1.27	1.65	(2000)	230	153	77
84	488 880	14.01	0.122	1.71	102.57	6.15	358	2.17	130.0	7.80	450	(6-70)	1.28	1.67	(2000)	233	155	78
85	494 700	14.18	0.121	1.72	102.94	6.18	359	2.17	130.0	7.80	450	(6-70)	1.29	1.67	(2000)	233	156	78
86	500 520	14.35	0.121	1.74	104.15	6.25	363	2.17	130.0	7.80	450	(6-70)	1.30	1.69	(2000)	236	157	79
87	506 340	14.51	0.120	1.74	104.49	6.27	365	2.17	130.0	7.80	450	(6-70)	1.31	1.70	(2000)	237	158	79
88	512 160	14.68	0.120	1.76	105.69	6.34	369	2.17	130.0	7.80	450	(6-70)	1.32	1.72	(2000)	240	160	80
89	517 980	14.85	0.120	1.78	106.89	6.41	373	2.17	130.0	7.80	450	(6-70)	1.34	1.74	(2000)	242	162	81
90	523 800	15.01	0.119	1.79	107.19	6.43	374	2.17	130.0	7.80	450	(6-70)	1.34	1.74	(2000)	243	162	81
91	529 620	15.18	0.119	1.81	108.38	6.50	378	2.17	130.0	7.80	450	(6-70)	1.36	1.76	(2000)	246	164	82
92	535 440	15.35	0.118	1.81	108.65	6.52	379	2.17	130.0	7.80	450	(6-70)	1.36	1.77	(2000)	246	164	82
93	541 260	15.51	0.118	1.83	109.83	6.59	383	2.17	130.0	7.80	450	(6-70)	1.37	1.79	(2000)	249	166	83
94	547 080	15.68	0.117	1.83	110.07	6.60	384	2.17	130.0	7.80	450	(6-70)	1.38	1.79	(2000)	250	166	83
95	552 900	15.85	0.117	1.85	111.25	6.67	388	2.17	130.0	7.80	450	(6-70)	1.39	1.81	(2000)	252	168	84
96	558 720	16.01	0.117	1.87	112.42	6.74	392	2.17	130.0	7.80	450	(6-70)	1.41	1.83	(2000)	255	170	85
97	564 540	16.18	0.116	1.88	112.62	6.76	393	2.17	130.0	7.80	450	(6-70)	1.41	1.83	(2000)	255	170	85
98	570 360	16.35	0.116	1.90	113.78	6.83	397	2.17	130.0	7.80	450	(6-70)	1.42	1.85	(2000)	258	172	86
99	576 180	16.51	0.116	1.92	114.94	6.90	401	2.17	130.0	7.80	450	(6-70)	1.44	1.87	(2000)	261	174	87
100	582 000	16.68	0.115	1.92	115.10	6.91	402	2.17	130.0	7.80	450	(6-70)	1.44	1.87	(2000)	261	174	87

Performance data

TransTherm® aqua F

Residential units standard apartment according to DIN 4708	Peak heat demand standard apartment according to DIN 4708 with preparation 10 min	Sum flow rate domestic hot water calculation flow rate according to DIN 4708	Simultaneity factor according to DIN 4708	Peak flow rate (DHW)	Peak flow rate (DHW)	Peak flow rate (DHW)	Peak output (DHW)	Peak flow rate TransTherm® aqua F (DHW)	Peak flow rate TransTherm® aqua F (DHW)	Peak flow rate TransTherm® aqua F (DHW)	DHW calorifier output TransTherm® aqua F	TransTherm® aqua F	Required heating water volume at 65/30 °C (35 K)	Required heating water buffer storage tank volume at 65/30 °C (35 K)	Buffer storage tank 1 EnerVal	Required recharging capacity	Required recharging capacity	Required recharging capacity
N	Preparation	Σ VR at DHW 60 °C	g	Vs at DHW 60 °C	Vs at DHW 60 °C	Vs at DHW 60 °C		Vs at DHW 60 °C	Vs at DHW 60 °C	Vs at DHW 60 °C	Q at HT 65/30 °C DHW 10/60 °C	Type			Type	Time: 20 min 65/30 °C (35 K)	Time: 30 min 65/30 °C (35 K)	Time: 60 min 65/30 °C (35 K)
	[Wh]	[l/s]		[l/s]	[l/min]	[m³/h]	[kW]	[l/s]	[l/min]	[m³/h]	[kW]		[m³]	[m³]		[kW]	[kW]	[kW]
1	5820	0.17	1.00	0.17	10.01	0.60	35	0.15	9.2	0.55	32	(6-10)	0.14	0.19	(200)	23	15	8
2	11640	0.33	0.680	0.23	13.61	0.82	47	0.24	14.3	0.86	60	(6-16)	0.19	0.25	(200)	31	21	10
3	17460	0.50	0.544	0.27	16.33	0.98	57	0.43	25.8	1.55	60	(6-16)	0.23	0.30	(300)	37	25	12
4	23280	0.67	0.466	0.31	18.66	1.12	65	0.38	23.0	1.38	80	(6-20)	0.27	0.35	(300)	42	28	14
5	29100	0.83	0.415	0.35	20.77	1.25	72	0.38	23.0	1.38	80	(6-20)	0.30	0.39	(500)	47	31	16
6	34920	1.00	0.377	0.38	22.64	1.36	79	0.38	23.0	1.38	80	(6-20)	0.32	0.42	(500)	51	34	17
7	40740	1.17	0.349	0.41	24.45	1.47	85	0.60	36.2	2.17	126	(6-30)	0.35	0.45	(500)	55	37	18
8	46560	1.33	0.349	0.47	27.94	1.68	97	0.60	36.2	2.17	126	(6-30)	0.40	0.52	(500)	63	42	21
9	52380	1.50	0.308	0.46	27.74	1.66	97	0.60	36.2	2.17	126	(6-30)	0.40	0.52	(500)	63	42	21
10	58200	1.67	0.292	0.49	29.23	1.75	102	0.60	36.2	2.17	126	(6-30)	0.42	0.54	(500)	66	44	22
11	64020	1.83	0.279	0.51	30.72	1.84	107	0.60	36.2	2.17	126	(6-30)	0.44	0.57	(500)	70	46	23
12	69840	2.00	0.268	0.54	32.19	1.93	112	0.60	36.2	2.17	126	(6-30)	0.46	0.60	(500)	73	49	24
13	75660	2.17	0.258	0.56	33.57	2.01	117	0.60	36.2	2.17	126	(6-30)	0.48	0.62	(500)	76	51	25
14	81480	2.34	0.249	0.58	34.89	2.09	122	0.60	36.2	2.17	126	(6-30)	0.50	0.65	(500)	79	53	26
15	87300	2.50	0.242	0.61	36.33	2.18	127	0.60	36.2	2.17	126	(6-30)	0.52	0.67	(800)	82	55	27
16	93120	2.67	0.235	0.63	37.63	2.26	131	0.83	49.7	2.98	173	(6-40)	0.54	0.70	(800)	85	57	28
17	98940	2.84	0.228	0.65	38.79	2.33	135	0.83	49.7	2.98	173	(6-40)	0.55	0.72	(800)	88	59	29
18	104760	3.00	0.223	0.67	40.17	2.41	140	0.83	49.7	2.98	173	(6-40)	0.57	0.75	(800)	91	61	30
19	110580	3.17	0.217	0.69	41.27	2.48	144	0.83	49.7	2.98	173	(6-40)	0.59	0.77	(800)	94	62	31
20	116400	3.34	0.212	0.71	42.44	2.55	148	0.83	49.7	2.98	173	(6-40)	0.61	0.79	(800)	96	64	32
21	122220	3.50	0.208	0.73	43.72	2.62	153	0.83	49.7	2.98	173	(6-40)	0.62	0.81	(800)	99	66	33
22	128040	3.67	0.204	0.75	44.92	2.70	157	0.83	49.7	2.98	173	(6-40)	0.64	0.83	(800)	102	68	34
23	133860	3.84	0.200	0.77	46.04	2.76	161	0.83	49.7	2.98	173	(6-40)	0.66	0.86	(800)	104	70	35
24	139680	4.00	0.196	0.78	47.08	2.82	164	0.83	49.7	2.98	173	(6-40)	0.67	0.87	(800)	107	71	36
25	145500	4.17	0.193	0.80	48.29	2.90	168	0.83	49.7	2.98	173	(6-40)	0.69	0.90	(800)	110	73	37
26	151320	4.34	0.190	0.82	49.44	2.97	173	0.83	49.7	2.98	173	(6-40)	0.71	0.92	(800)	112	75	37
27	157140	4.50	0.187	0.84	50.53	3.03	176	0.83	49.7	2.98	173	(6-40)	0.72	0.94	(800)	115	76	38
28	162960	4.67	0.184	0.86	51.56	3.09	180	1.03	61.7	3.70	215	(6-50)	0.74	0.96	(800)	117	78	39
29	168780	4.84	0.181	0.88	52.54	3.15	183	1.03	61.7	3.70	215	(6-50)	0.75	0.98	(800)	119	79	40
30	174600	5.00	0.179	0.90	53.75	3.22	188	1.03	61.7	3.70	215	(6-50)	0.77	1.00	(1000)	122	81	41
31	180420	5.17	0.176	0.91	54.61	3.28	191	1.03	61.7	3.70	215	(6-50)	0.78	1.01	(1000)	124	83	41
32	186240	5.34	0.174	0.93	55.73	3.34	194	1.03	61.7	3.70	215	(6-50)	0.80	1.04	(1000)	126	84	42
33	192060	5.50	0.172	0.95	56.81	3.41	198	1.03	61.7	3.70	215	(6-50)	0.81	1.06	(1000)	129	86	43
34	197880	5.67	0.170	0.96	57.85	3.47	202	1.03	61.7	3.70	215	(6-50)	0.83	1.07	(1000)	131	87	44
35	203700	5.84	0.168	0.98	58.85	3.53	205	1.03	61.7	3.70	215	(6-50)	0.84	1.09	(1000)	133	89	44
36	209520	6.01	0.166	1.00	59.81	3.59	209	1.03	67.7	3.70	215	(6-50)	0.85	1.11	(1000)	136	90	45
37	215340	6.17	0.164	1.01	60.73	3.64	212	1.03	61.7	3.70	215	(6-50)	0.87	1.13	(1000)	138	92	46
38	221160	6.34	0.163	1.03	61.99	3.72	216	1.03	61.7	3.70	215	(6-50)	0.89	1.15	(1000)	141	94	47
39	226980	6.51	0.161	1.05	62.84	3.77	219	1.06	63.7	3.82	220	(6-60)	0.90	1.17	(1000)	143	95	48
40	232800	6.67	0.159	1.06	63.65	3.82	222	1.06	63.7	3.82	220	(6-60)	0.91	1.18	(1000)	144	96	48
41	238620	6.84	0.158	1.08	64.84	3.89	226	1.35	81.0	4.86	280	(6-70)	0.93	1.20	(1000)	147	98	49
42	244440	7.01	0.156	1.09	65.58	3.93	229	1.35	81.0	4.86	280	(6-70)	0.94	1.22	(1000)	149	99	50
43	250260	7.17	0.155	1.11	66.71	4.00	233	1.35	81.0	4.86	280	(6-70)	0.95	1.24	(1000)	151	101	50
44	256080	7.34	0.154	1.13	67.82	4.07	237	1.35	81.0	4.86	280	(6-70)	0.97	1.26	(1500)	154	103	51
45	261900	7.51	0.152	1.14	68.46	4.11	239	1.35	81.0	4.86	280	(6-70)	0.98	1.27	(1500)	155	104	52
46	267720	7.67	0.151	1.16	69.52	4.17	243	1.35	81.0	4.86	280	(6-70)	0.99	1.29	(1500)	158	105	53
47	273540	7.84	0.150	1.18	70.56	4.23	246	1.35	81.0	4.86	280	(6-70)	1.01	1.31	(1500)	160	107	53
48	279360	8.01	0.149	1.19	71.58	4.29	250	1.35	81.0	4.86	280	(6-70)	1.02	1.33	(1500)	162	108	54
49	285180	8.17	0.148	1.21	72.58	4.35	253	1.35	81.0	4.86	280	(6-70)	1.04	1.35	(1500)	165	110	55
50	291000	8.34	0.146	1.22	73.06	4.38	255	1.35	81.0	4.86	280	(6-70)	1.04	1.36	(1500)	166	110	55
51	296820	8.51	0.145	1.23	74.01	4.44	258	1.35	81.0	4.86	280	(6-70)	1.06	1.37	(1500)	168	112	56
52	302640	8.67	0.144	1.25	74.94	4.50	261	1.35	81.0	4.86	280	(6-70)	1.07	1.39	(1500)	170	113	57
53	308460	8.84	0.143	1.26	75.86	4.55	265	1.35	81.0	4.86	280	(6-70)	1.08	1.41	(1500)	172	115	57
54	314280	9.01	0.142	1.28	76.75	4.60	268	1.35	81.0	4.86	280	(6-70)	1.10	1.43	(1500)	174	116	58

Residential units standard apartment according to DIN 4708	Peak heat demand standard apartment according to DIN 4708 with preparation 10 min	Sum flow rate domestic hot water calculation flow rate according to DIN 4708	Simultaneity factor according to DIN 4708	Peak flow rate (DHW)	Peak flow rate (DHW)	Peak flow rate (DHW)	Peak output (DHW)	Peak flow rate TransTherm® aqua F (DHW)	Peak flow rate TransTherm® aqua F (DHW)	Peak flow rate TransTherm® aqua F (DHW)	DHW calorifier output TransTherm® aqua F	TransTherm® aqua F	Required heating water volume at 65/30 °C (35 K)	Required heating water buffer storage tank volume at 65/30 °C (35 K)	Buffer storage tank 1 EnerVal	Required recharging capacity	Required recharging capacity	Required recharging capacity
	[Wh]	[l/s]		[l/s]	[l/min]	[m³/h]	[kW]	[l/s]	[l/min]	[m³/h]	[kW]		[m³]	[m³]		[kW]	[kW]	[kW]
55	320 100	9.17	0.141	1.29	77.62	4.66	271	1.35	81.0	4.86	280	(6-70)	1.11	1.44	(1500)	176	117	59
56	325 920	9.34	0.140	1.31	78.47	4.71	274	1.35	81.0	4.86	280	(6-70)	1.12	1.46	(1500)	178	119	59
57	331 740	9.51	0.140	1.33	79.87	4.79	279	1.35	81.0	4.86	280	(6-70)	1.14	1.48	(1500)	181	121	60
58	337 560	9.67	0.139	1.34	80.69	4.84	282	1.83	109.8	6.59	380	(6-80)	1.15	1.50	(1500)	183	122	61
59	343 380	9.84	0.138	1.36	81.49	4.89	284	1.83	109.8	6.59	380	(6-80)	1.16	1.51	(1500)	185	123	62
60	349 200	10.01	0.137	1.37	82.27	4.94	287	1.83	109.8	6.59	380	(6-80)	1.18	1.53	(1500)	187	124	62
61	355 020	10.18	0.136	1.38	83.03	4.98	290	1.83	109.8	6.59	380	(6-80)	1.19	1.54	(1500)	188	126	63
62	360 840	10.34	0.135	1.40	83.77	5.03	292	1.83	109.8	6.59	380	(6-80)	1.20	1.56	(1500)	190	127	63
63	366 660	10.51	0.135	1.42	85.12	5.11	297	1.83	109.8	6.59	380	(6-80)	1.22	1.58	(1500)	193	129	64
64	372 480	10.68	0.134	1.43	85.83	5.15	299	1.83	109.8	6.59	380	(6-80)	1.23	1.59	(1500)	195	130	65
65	378 300	10.84	0.133	1.44	86.52	5.19	302	1.83	109.8	6.59	380	(6-80)	1.24	1.61	(1500)	196	131	65
66	384 120	11.01	0.132	1.45	87.19	5.23	304	1.83	109.8	6.59	380	(6-80)	1.25	1.62	(1500)	198	132	66
67	389 940	11.18	0.132	1.48	88.52	5.31	309	1.83	109.8	6.59	380	(6-80)	1.26	1.64	(1500)	201	134	67
68	395 760	11.34	0.131	1.49	89.16	5.35	311	1.83	109.8	6.59	380	(6-80)	1.27	1.66	(1500)	202	135	67
69	401 580	11.51	0.130	1.50	89.78	5.39	313	1.83	109.8	6.59	380	(6-80)	1.28	1.67	(1500)	204	136	68
70	407 400	11.68	0.130	1.52	91.08	5.46	318	1.83	109.8	6.59	380	(6-80)	1.30	1.69	(1500)	207	138	69
71	413 220	11.84	0.129	1.53	91.67	5.50	320	1.83	109.8	6.59	380	(6-80)	1.31	1.70	(1500)	208	139	69
72	419 040	12.01	0.128	1.54	92.24	5.53	322	1.83	109.8	6.59	380	(6-80)	1.32	1.71	(1500)	209	139	70
73	424 860	12.18	0.128	1.56	93.52	5.61	326	1.83	109.8	6.59	380	(6-80)	1.34	1.74	(1500)	212	141	71
74	430 680	12.34	0.127	1.57	94.06	5.64	328	1.83	109.8	6.59	380	(6-80)	1.34	1.75	(1500)	213	142	71
75	436 500	12.51	0.127	1.59	95.33	5.72	333	1.83	109.8	6.59	380	(6-80)	1.36	1.77	(1500)	216	144	72
76	442 320	12.68	0.126	1.60	95.84	5.75	334	1.83	109.8	6.59	380	(6-80)	1.37	1.78	(1500)	217	145	72
77	448 140	12.84	0.126	1.62	97.10	5.83	339	1.83	109.8	6.59	380	(6-80)	1.39	1.80	(1500)	220	147	73
78	453 960	13.01	0.125	1.63	97.58	5.86	340	1.83	109.8	6.59	380	(6-80)	1.39	1.81	(1500)	221	148	74
79	459 780	13.18	0.124	1.63	98.04	5.88	342	1.83	109.8	6.59	380	(6-80)	1.40	1.82	(1500)	222	148	74
80	465 600	13.34	0.124	1.65	99.29	5.96	346	1.83	109.8	6.59	380	(6-80)	1.42	1.84	(2000)	225	150	75
81	471 420	13.51	0.123	1.66	99.72	5.98	348	1.83	109.8	6.59	380	(6-80)	1.42	1.85	(2000)	226	151	75
82	477 240	13.68	0.123	1.68	100.95	6.06	352	1.83	109.8	6.59	380	(6-80)	1.44	1.88	(2000)	229	153	76
83	483 060	13.85	0.122	1.69	101.35	6.08	354	1.83	109.8	6.59	380	(6-80)	1.45	1.88	(2000)	230	153	77
84	488 880	14.01	0.122	1.71	102.57	6.15	358	1.83	109.8	6.59	380	(6-80)	1.47	1.91	(2000)	233	155	78
85	494 700	14.18	0.121	1.72	102.94	6.18	359	1.83	109.8	6.59	380	(6-80)	1.47	1.91	(2000)	233	156	78
86	500 520	14.35	0.121	1.74	104.15	6.25	363	1.83	109.8	6.59	380	(6-80)	1.49	1.93	(2000)	236	157	79
87	506 340	14.51	0.120	1.74	104.49	6.27	365	1.83	109.8	6.59	380	(6-80)	1.49	1.94	(2000)	237	158	79
88	512 160	14.68	0.120	1.76	105.69	6.34	369	1.83	109.8	6.59	380	(6-80)	1.51	1.96	(2000)	240	160	80
89	517 980	14.85	0.120	1.78	106.89	6.41	373	1.83	109.8	6.59	380	(6-80)	1.53	1.99	(2000)	242	162	81
90	523 800	15.01	0.119	1.79	107.19	6.43	374	1.83	109.8	6.59	380	(6-80)	1.53	1.99	(2000)	243	162	81
91	529 620	15.18	0.119	1.81	108.38	6.50	378	1.83	109.8	6.59	380	(6-80)	1.55	2.01	(2000)	246	164	82
92	535 440	15.35	0.118	1.81	108.65	6.52	379	1.83	109.8	6.59	380	(6-80)	1.55	2.02	(2000)	246	164	82
93	541 260	15.51	0.118	1.83	109.83	6.59	383	1.83	109.8	6.59	380	(6-80)	1.57	2.04	(2000)	249	166	83
94	547 080	15.68	0.117	1.83	110.07	6.60	384	1.83	109.8	6.59	380	(6-80)	1.57	2.04	(2000)	250	166	83
95	552 900	15.85	0.117	1.85	111.25	6.67	388	2.51	150.3	9.02	520	(6-90)	1.59	2.07	(2000)	252	168	84
96	558 720	16.01	0.117	1.87	112.42	6.74	392	2.51	150.3	9.02	520	(6-90)	1.61	2.09	(2000)	255	170	85
97	564 540	16.18	0.116	1.88	112.62	6.76	393	2.51	150.3	9.02	520	(6-90)	1.61	2.09	(2000)	255	170	85
98	570 360	16.35	0.116	1.90	113.78	6.83	397	2.51	150.3	9.02	520	(6-90)	1.63	2.11	(2000)	258	172	86
99	576 180	16.51	0.116	1.92	114.94	6.90	401	2.51	150.3	9.02	520	(6-90)	1.64	2.13	(2000)	261	174	87
100	582 000	16.68	0.115	1.92	115.10	6.91	402	2.51	150.3	9.02	520	(6-90)	1.64	2.14	(2000)	261	174	87

Performance data

TransTherm® aqua F (6-60)

Performance data		Q	VS	VS	VS	Buffer storage tank
primary	secondary	kW	l/s	l/min	m ³ /h	min. content in l ¹⁾
70 °C/30 °C	10 °C/60 °C	350	1.67	100.33	6.02	1405
65 °C/30 °C	10 °C/60 °C	220	1.05	63.07	3.78	883
65 °C/30 °C	10 °C/55 °C	315	1.67	100.33	6.02	1405
65 °C/30 °C	10 °C/50 °C	280	1.67	100.33	6.02	1405
60 °C/30 °C	10 °C/55 °C	255	1.35	81.22	4.87	1137
60 °C/30 °C	10 °C/50 °C	280	1.67	100.33	6.02	1405
55 °C/30 °C	10 °C/50 °C	230	1.37	82.42	4.95	1154
55 °C/30 °C	10 °C/45 °C	245	1.67	100.33	6.02	1405

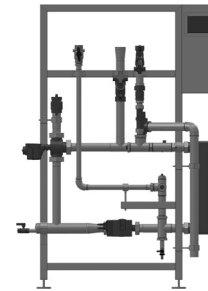

TransTherm® aqua F (6-70)

Performance data		Q	VS	VS	VS	Buffer storage tank
primary	secondary	kW	l/s	l/min	m ³ /h	min. content in l ¹⁾
70 °C/30 °C	10 °C/60 °C	450	2.15	129.00	7.74	1806
65 °C/30 °C	10 °C/60 °C	280	1.34	80.27	4.82	1124
65 °C/30 °C	10 °C/55 °C	405	2.15	129.00	7.74	1806
65 °C/30 °C	10 °C/50 °C	360	2.15	129.00	7.74	1806
60 °C/30 °C	10 °C/55 °C	320	1.70	101.93	6.12	1427
60 °C/30 °C	10 °C/50 °C	360	2.15	129.00	7.74	1806
55 °C/30 °C	10 °C/50 °C	290	1.73	103.92	6.24	1455
55 °C/30 °C	10 °C/45 °C	315	2.15	129.00	7.74	1806

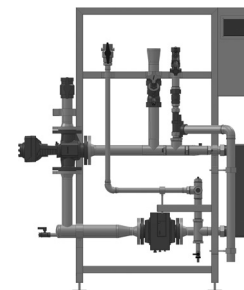

TransTherm® aqua F (6-80)

Performance data		Q	VS	VS	VS	Buffer storage tank
primary	secondary	kW	l/s	l/min	m ³ /h	min. content in l ¹⁾
70 °C/30 °C	10 °C/60 °C	580	2.77	166.27	9.98	2328
65 °C/30 °C	10 °C/60 °C	380	1.82	108.93	6.54	1525
65 °C/30 °C	10 °C/55 °C	530	2.81	168.81	10.13	2363
65 °C/30 °C	10 °C/50 °C	490	2.93	175.58	10.54	2458
60 °C/30 °C	10 °C/55 °C	420	2.23	133.78	8.03	1873
60 °C/30 °C	10 °C/50 °C	485	2.90	173.79	10.43	2433
55 °C/30 °C	10 °C/50 °C	380	2.27	136.17	8.17	1906
55 °C/30 °C	10 °C/45 °C	430	2.93	176.10	10.57	2465

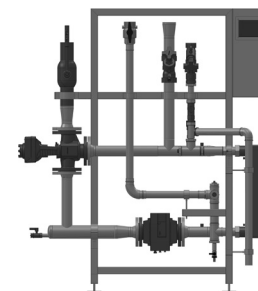

TransTherm® aqua F (6-90)

Performance data		Q	VS	VS	VS	Buffer storage tank
primary	secondary	kW	l/s	l/min	m ³ /h	min. content in l ¹⁾
70 °C/30 °C	10 °C/60 °C	700	3.34	200.67	12.04	2809
65 °C/30 °C	10 °C/60 °C	520	2.48	149.07	8.94	2087
65 °C/30 °C	10 °C/55 °C	630	3.34	200.67	12.04	2809
65 °C/30 °C	10 °C/50 °C	560	3.34	200.67	12.04	2809
60 °C/30 °C	10 °C/55 °C	530	2.81	168.81	10.13	2363
60 °C/30 °C	10 °C/50 °C	560	3.34	200.67	12.04	2809
55 °C/30 °C	10 °C/50 °C	480	2.87	172.00	10.32	2408
55 °C/30 °C	10 °C/45 °C	490	3.34	200.67	12.04	2809

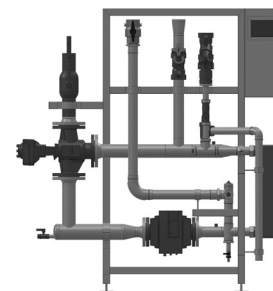

¹⁾ The calculation for the content of the buffer storage tank depends on the temperature spread. Here, 0.7 has been set for the temperature spread and 2 for short non-draw-off times. See calculation of the required buffer volume

Performance data

Calculation of the required buffer volume

In order to provide the required energy for domestic water heating, a fresh water station is generally connected to a buffer storage tank. The volume of the buffer storage tank is determined by the domestic hot water requirement of the installation, the storage temperature in the buffer storage tank and the user behaviour.

$$VP = V \times t \times (Tp/Tww) \times Sn$$

- VP Required minimum volume of the buffer storage tank
- V Calculated peak flow of the fresh water module
- t Time for which the peak flow is required. The value can be gear towards, for example the duration of the tub filling, user information or the standard value from DIN 4708 (10 min.)
- (Tp/Tww) For the temperature spread between the buffer storage tank and domestic water
 - 0.5 for a high temperature spread (e.g. 90/45 °C)
 - 0.7 for a medium temperature spread (e.g. 70/45 °C)
 - 1 for a low temperature spread (e.g. 55/45 °C)
- Sn Safety factor for observing user behaviour
 - 1 normal non-draw-off times
 - 2 short non-draw-off times
 - 3-4 very short non-draw-off times

Example calculation

VP	V	t	(Tp/Tww)	Sn
(l)	(l/min)	(min)		
1576	78.8	10.0	1.0	2.0

	Result
	Input

Pressure drop ($\Delta P / Q$ max) – domestic water side (secondary)

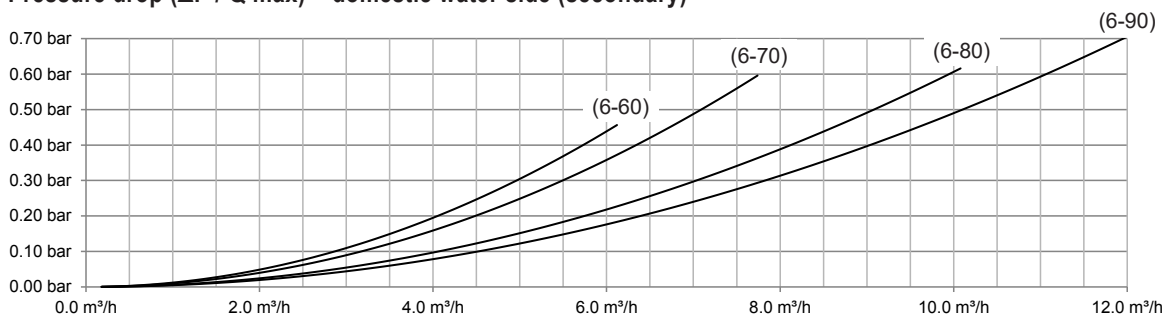

Circulating pump characteristic curves

for circulation set 3/4"

$\Delta p-v$ (variable)

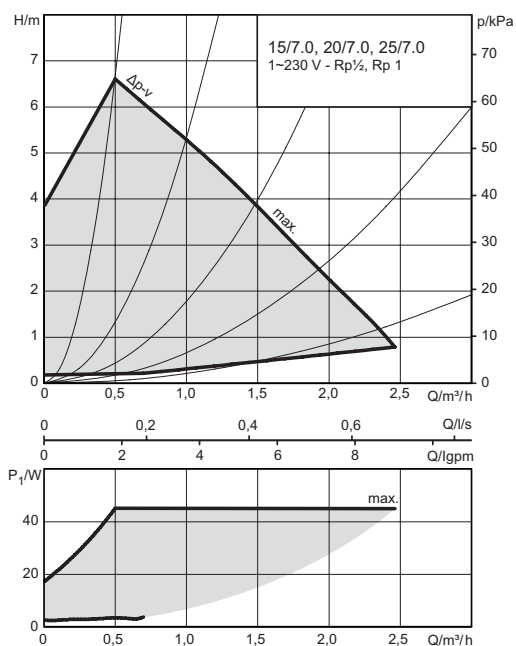

Constant speed

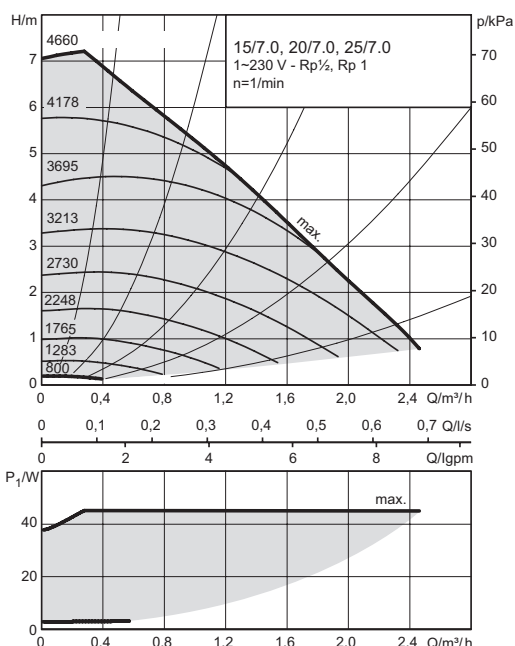

for circulation set 1" and 1 1/4"

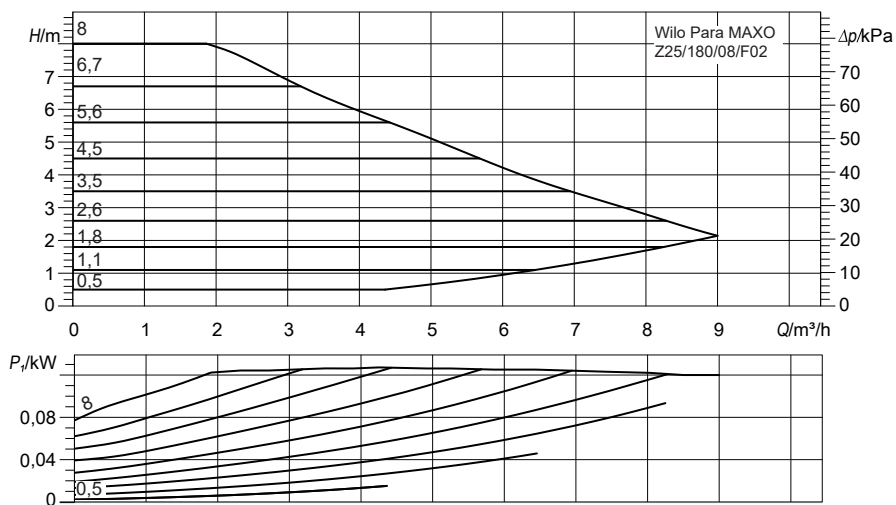

Fresh water module TransTherm® aqua F (6-60)
(Dimensions in mm)

*** For application according to the SVGW**
The installation of ball valves is not permitted in Switzerland according to SVGW regulation W3.

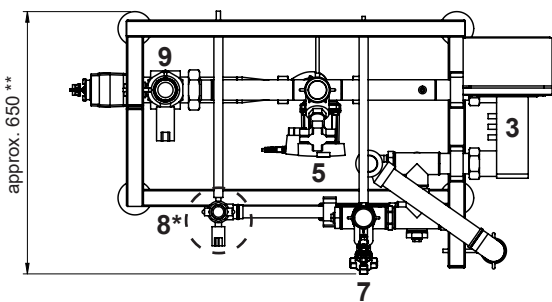
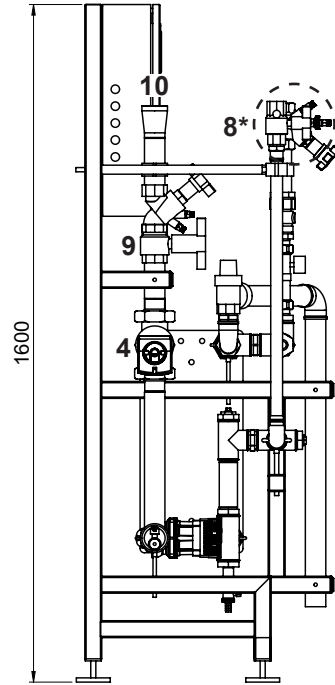
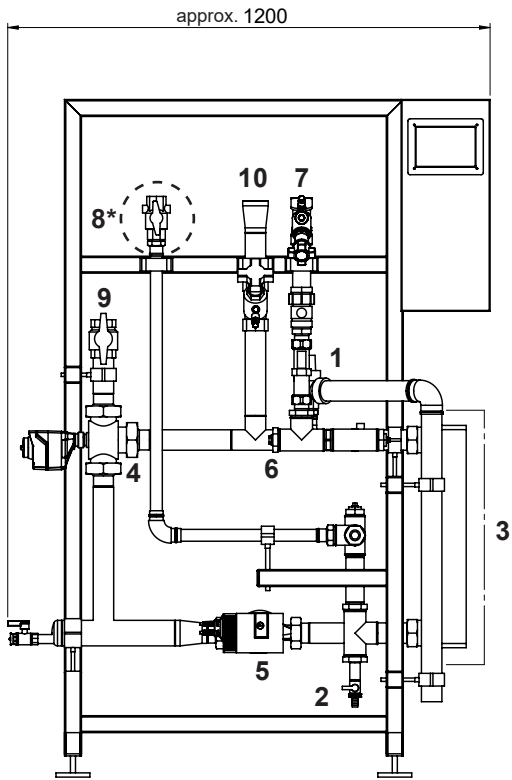

Version incl. circulation set

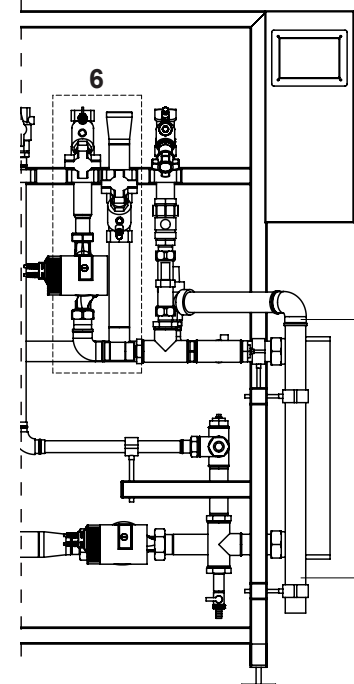

** With circulation 680

TransTherm® aqua F (6-60)	Weight in kg
	123

- 1 Safety valve
Hot water 10 bar
 - 2 Filling/drain valve
 - 3 Heat exchanger
 - 4 Three-way valve
 - 5 Circulating pump
 - 6 Circulation ¹⁾ DN 32, Rp 1¼" (DN 25, Rp 1") (IT)
 - 7 Cold water DN 32, Rp 1¼" (IT)
 - 8* Hot water DN 32, Rp 1¼" (IT)
 - 9 Flow heating water DN 40, Rp 1½" (IT)
 - 10 Return heating water DN 40, Rp 1½" (IT)
- ¹⁾ Optional, connection and installation on site

Fresh water module TransTherm® aqua F (6-70)
(Dimensions in mm)

* For application according to the SVGW
The installation of ball valves is not permitted in Switzerland according to SVGW regulation W3.

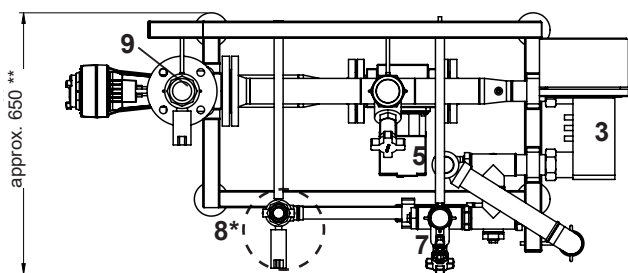
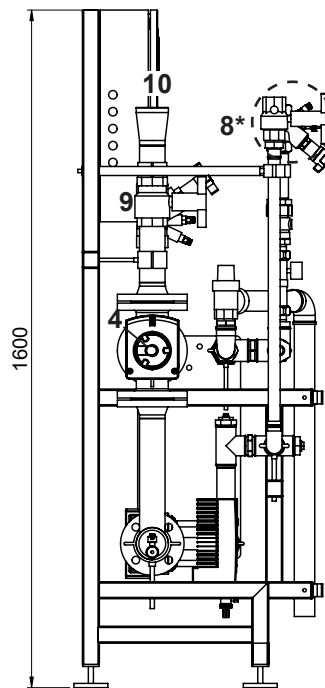
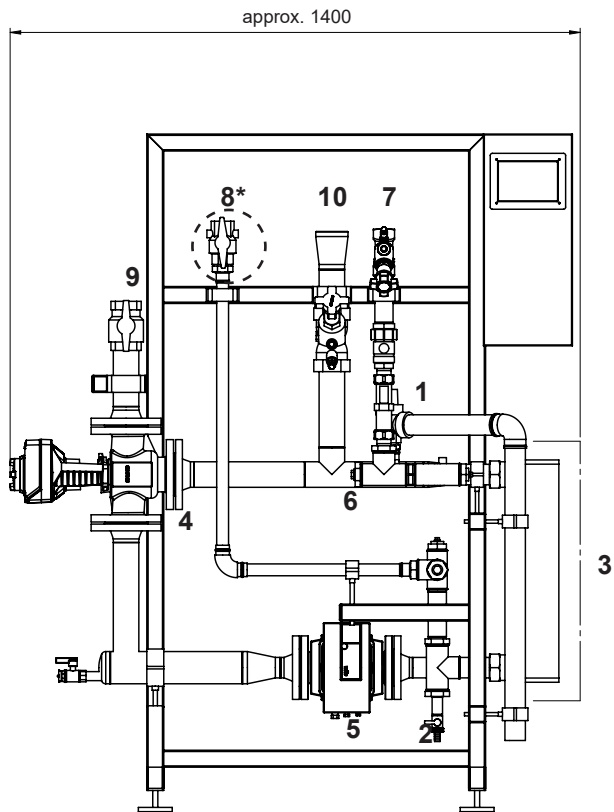

Version incl. circulation set

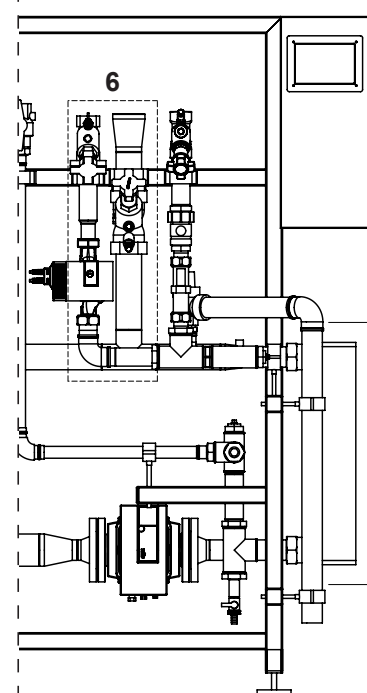

** With circulation 680

TransTherm® aqua F (6-70)	Weight in kg
	172

- 1 Safety valve
Hot water 10 bar
 - 2 Filling/drain valve
 - 3 Heat exchanger
 - 4 Three-way valve
 - 5 Circulating pump
 - 6 Circulation ¹⁾ DN 32, Rp 1 1/4" (DN 25, Rp 1") (IT)
 - 7 Cold water DN 32, Rp 1 1/4" (IT)
 - 8* Hot water DN 32, Rp 1 1/4" (IT)
 - 9 Flow heating water DN 50, Rp 2" (IT)
 - 10 Return heating water DN 50, Rp 2" (IT)
- ¹⁾ Optional, connection and installation on site

Fresh water module TransTherm® aqua F (6-80)
(Dimensions in mm)

*** For application according to the SVGW**
The installation of ball valves is not permitted in Switzerland according to SVGW regulation W3.

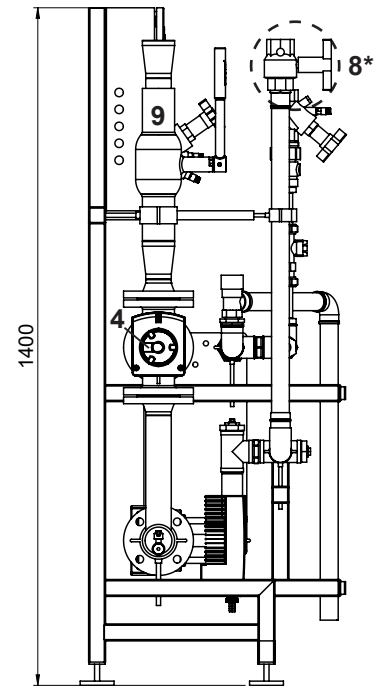
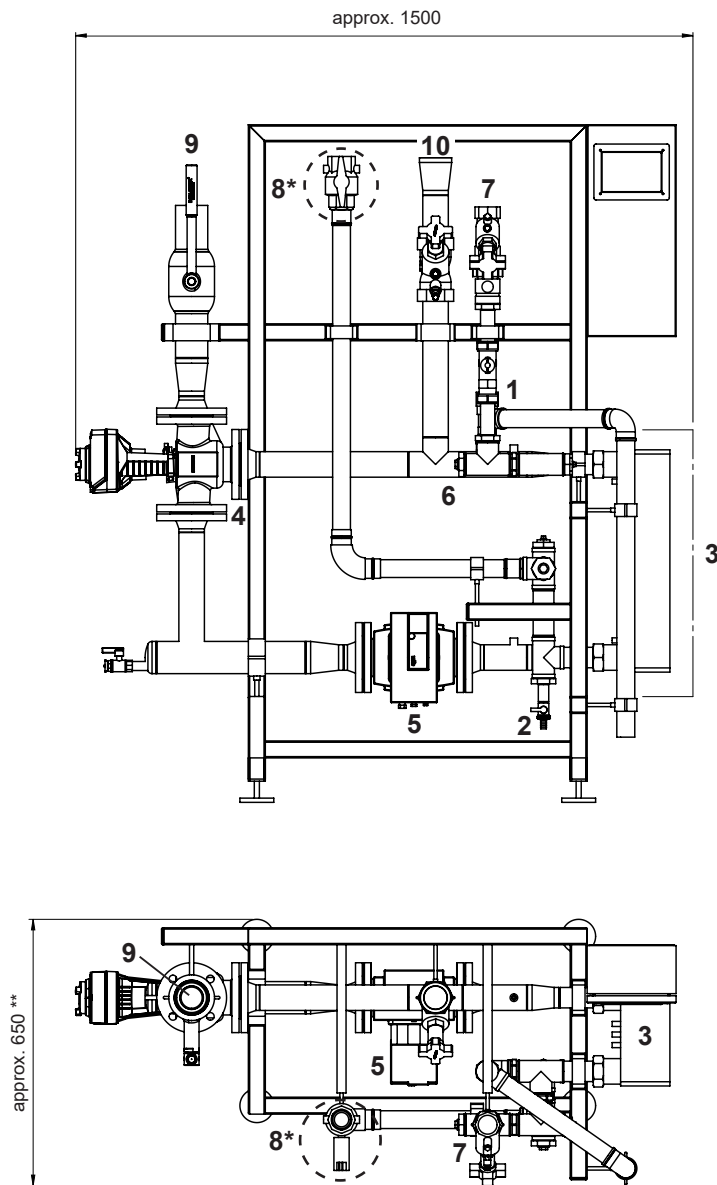

Version incl. circulation set

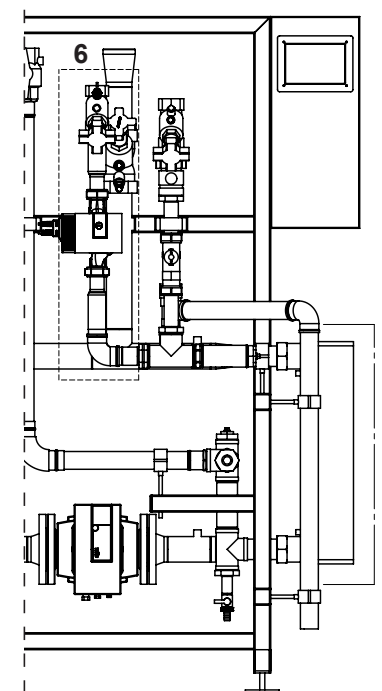

** With circulation 680

TransTherm® aqua F (6-80) Weight in kg 202

- 1 Safety valve Hot water 10 bar
 - 2 Filling/drain valve
 - 3 Heat exchanger
 - 4 Three-way valve
 - 5 Circulating pump
 - 6 Circulation ¹⁾ DN 32, Rp 1¼" (DN 25, Rp 1") (IT)
 - 7 Cold water DN 40, Rp 1½" (IT)
 - 8* Hot water DN 40, Rp 1½" (IT)
 - 9 Flow heating water DN 65 AE (weld-on end)
 - 10 Return heating water DN 65 AE (weld-on end)
- ¹⁾ Optional, connection and installation on site

Fresh water module TransTherm® aqua F (6-90)
(Dimensions in mm)

* For application according to the SVGW
The installation of ball valves is not permitted in Switzerland according to SVGW regulation W3.

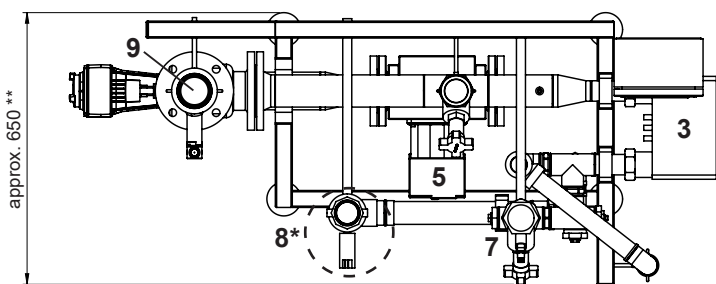
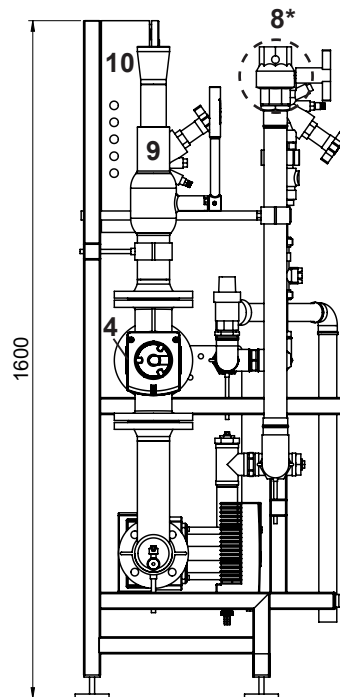
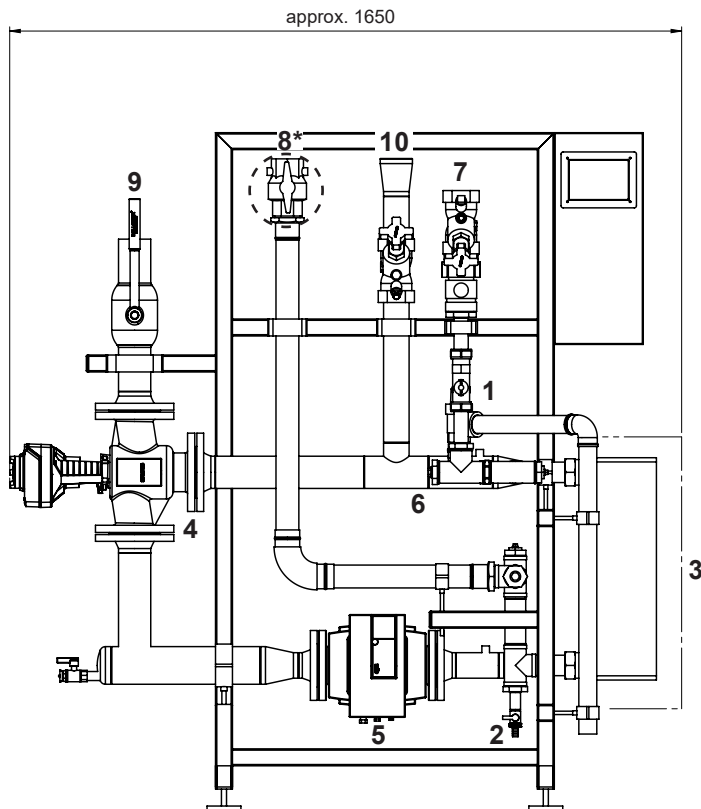

Version incl. circulation set

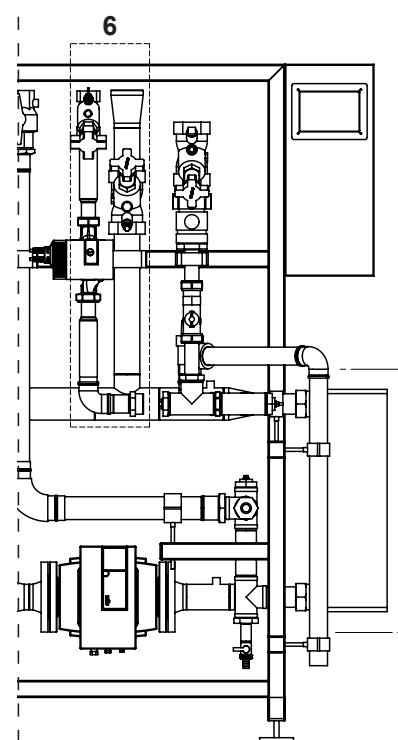

** With circulation 700

TransTherm® aqua F	Weight in kg
(6-90)	214

- 1 Safety valve
Hot water 10 bar
 - 2 Filling/drain valve
 - 3 Heat exchanger
 - 4 Three-way valve
 - 5 Circulating pump
 - 6 Circulation ¹⁾ DN 32, Rp 1¼" (DN 25, Rp 1") (IT)
 - 7 Cold water DN 50, Rp 2" (IT)
 - 8* Hot water DN 50, Rp 2" (IT)
 - 9 Flow heating water DN 65 AE (weld-on end)
 - 10 Return heating water DN 65 AE (weld-on end)
- ¹⁾ Optional, connection and installation on site

Water heating
TransTherm® aqua F

*** For application according to the SVGW**
The installation of ball valves is not permitted in Switzerland according to SVGW regulation W3.

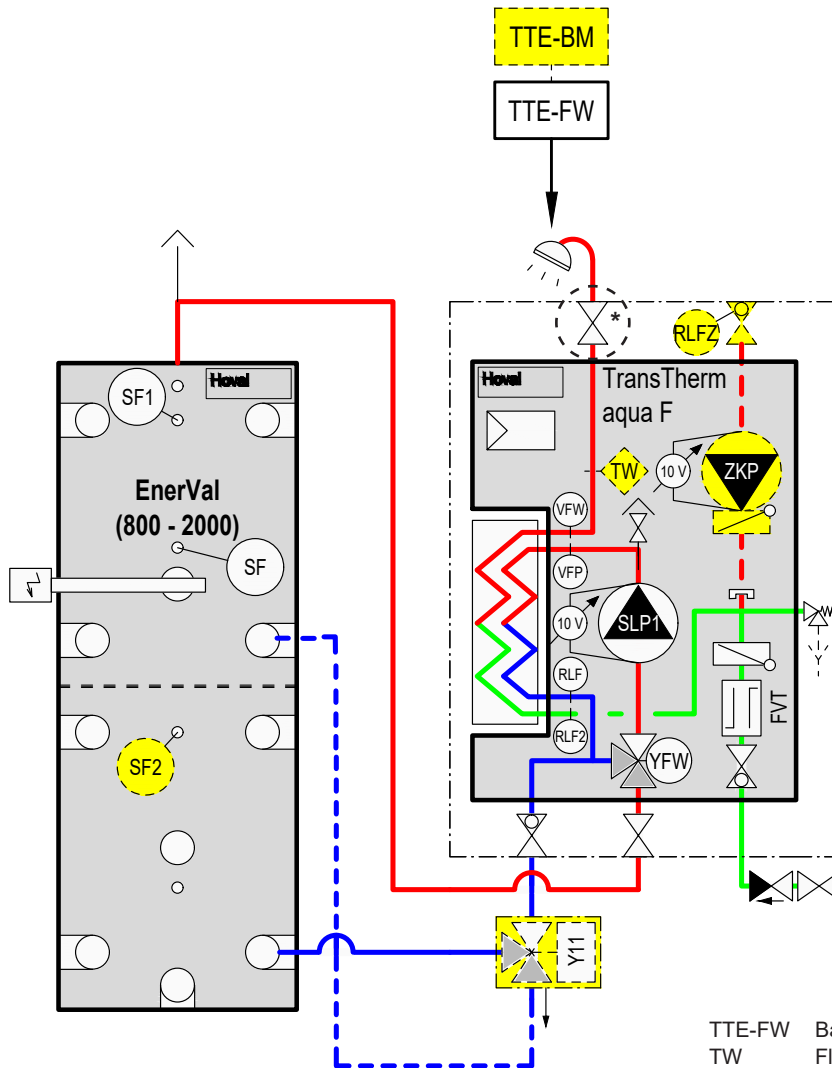

- TTE-FW Basic module district heating/fresh water
 - TW Flow temperature monitor (if required)
 - VFP Flow sensor primary
 - VFW Flow sensor DHW
 - RLF Return sensor primary
 - RLF2 Return sensor domestic cold water
 - SF Calorifier sensor
 - SF1 Calorifier sensor 1
 - RLFZ Circulation sensor
 - SLP1 Calorifier charging pump primary
 - FVT Flow rate sensor
 - YFW Three-way valve with actuator
 - ZKP Recirculation pump
 - Y11 Return switching with actuator
- Option*
- BM TopTronic® E control module
 - SF2 Calorifier sensor 2

Hoval quality.
You can count on us.

Hoval is one of the leading international companies for heating and indoor climate solutions. Drawing on more than 80 years of experience and benefiting from a close-knit team culture, the Hoval Group delivers exciting solutions and develops technically superior products. This leadership role requires a sense of responsibility for energy and the environment, which is expressed in an intelligent combination of different heating technologies and customised indoor climate solutions.

Hoval also provides personal consultations and comprehensive customer service. With around 2500 employees in 15 companies around the world, Hoval sees itself not as a conglomerate, but as a large family that thinks and acts globally.

Hoval heating and indoor climate solutions are currently exported to more than 50 countries.

Responsibility for energy and environment

Your Hoval partner

Liechtenstein

Hoval Aktiengesellschaft
9490 Vaduz
+423 399 24 00
hoval.com

United Kingdom

Hoval Ltd.
Newark Notts. NG 24 1JN
+44 1636 672 711
hoval.co.uk

Hoval TransTherm[®] aqua

Calorifier continuous flow system

TransTherm[®] aqua FS (7-10)-(7-90)

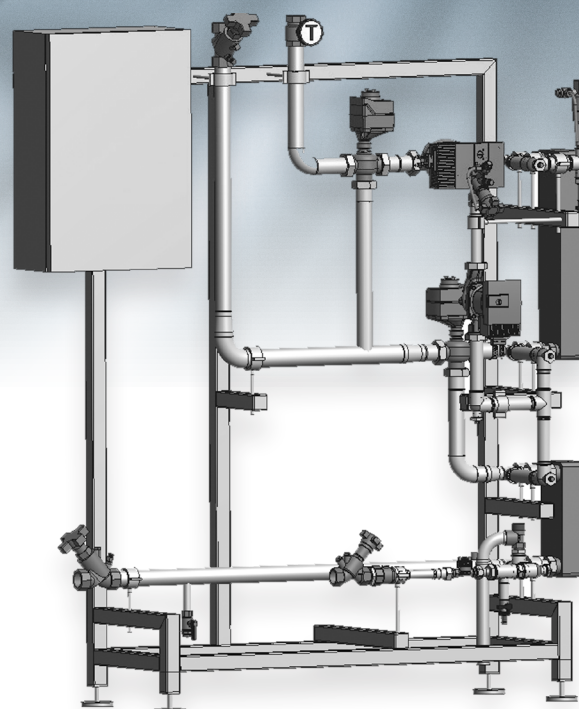

Table of contents

■ Description	5
■ Part numbers	7
■ Technical data	10
■ Dimensions	18
■ Example	20

Calorifier continuous flow system

Consisting of:

- fresh water module TransTherm® aqua FS
- buffer storage tank (option)

Fresh water module TransTherm® aqua FS

Consisting of:

Charging circuit flow:

- ball valve with thermometer handle
- three-way valve
- drive Siemens SAT 61 (0-10 V)
- Stratos pump
- sleeve for cable sensor M10 x 1
- sleeve for AGFW sensor

Charging circuit high temperature return:

- flow rate limiter Hydrocontrol VTR
- test port OVENTROP set 2
- three-way valve
- drive Siemens SAT 61 (0-10 V)
- sleeve for cable sensor M10 x 1
- sleeve for AGFW sensor

Charging circuit low temperature return:

- flow rate limiter Hydrocontrol VTR
- test port OVENTROP set 2
- ball valve WESA 1533
- sleeve for cable sensor M10 x 1
- sleeve for AGFW sensor

Heat exchanger supplementary heater:

- plate heat exchanger DANFOSS

Heat exchanger preheater:

- plate heat exchanger DANFOSS

Domestic hot water DHW:

- ball valve OVENTROP Optibal TW
- bimetallic thermometer OVENTROP TW
- sampling valve OVENTROP Aquastrom P (optional)
- ball valve OVENTROP
- sleeve for AGFW sensor

Domestic hot water circulation DHWC:

- flow rate limiter Aquastrom
- sampling valve OVENTROP Aquastrom P
- measurement nozzle OVENTROP
- circulating pump
- non-return valve TS73S
- sleeve for AGFW sensor

Domestic water DW:

- flow rate limiter Aquastrom C
- non-return valve ROSSWEINER
- adapter
- flow rate sensor HUBA
- ball valve OVENTROP
- sleeve for AGFW sensor
- diaphragm safety valve

Control panel control system:

- control panel casing SCHNEIDER
- control TTE-FW
- fuses
- sockets
- terminals

Stand frame:

- frame with corrosion protection coating RAL 9005
- height-adjustable and vibration-damped feet

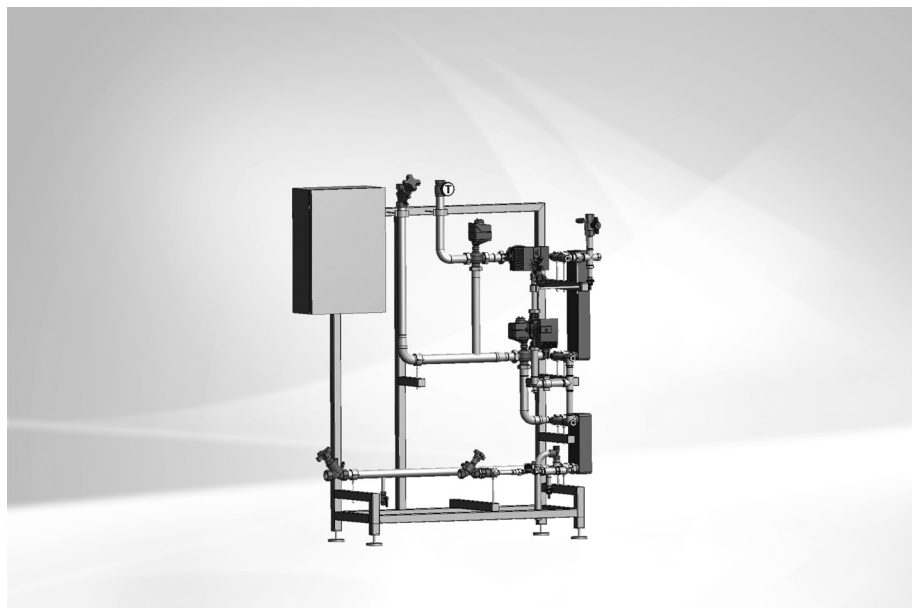

Range

Fresh water module

TransTherm® aqua FS type	Output kW
(7-10)	50
(7-16)	90
(7-20)	130
(7-30)	175
(7-40)	220
(7-50)	275
(7-60)	358
(7-70)	453
(7-80)	569
(7-90)	717

Thermal insulation:

- thermal insulation of the heat exchanger with 30 mm EPP mouldings
- thermal insulation of the pipes with EPP mouldings. insulation thickness of 50 % according to EnEV
- deep black, similar to RAL 9005
- suitable for damp rooms
- CFC-free
- normal flammability according to DIN 4102-1 and EN 13501-1 (fuel class: B2)
- no bleaching or disintegration of the insulation under the influence of UV

Delivery

- The buffer storage tank required is not included in the scope of delivery

On site

- Electrical connection of the controller

Suitable buffer storage tanks
 see separate chapter

Delivery time on request

TopTronic® E controller

TopTronic® E basic module
District heating/fresh water

- Control unit for controlling district heating transfer stations in non-communicative networks and the corresponding consumers with integrated control functions for
 - primary valve control
 - cascade management
 - 1 heating circuit with mixer
 - 1 heating circuit without mixer
 - 1 hot water charging circuit
 - various additional functions
- Various functions for domestic hot water:
 - selection of different basic programs (week programs, eco mode, holiday, etc.)
 - various operating modes (e.g. accumulator priority or parallel mode)
 - buffer storage circuit on the primary or secondary side
 - adjustable loading criteria (e.g. adjustable loading times, undershooting the minimum nominal value, etc.)
 - adjustable switch-off criteria (e.g. achieving the set value, achieving the lower sensor set value, etc.)
 - adjustable loading block (if the loading flow temperature is too low, the setpoint temperature is not reached, differential temperature-dependent solar circuit control)

- Definable switching times for circulating pump control
- Outdoor sensor
- Immersion sensor (calorifier sensor)
- Contact sensor (flow temperature sensor)
- Complete plug set for district heating module
- Speed-controlled pumps

No further module expansions or controller modules can be installed in the control panel!

Option

TopTronic® E control module

- Simple, intuitive operating concept
- Display of the most important operating states
- Configurable start screen
- Operating mode selection
- Configurable day and week programmes
- Operation of all connected Hoval CAN bus modules
- Commissioning wizard
- Service and maintenance function
- Fault message management
- Analysis function
- Weather display (with HovalConnect option)
- Adaptation of the heating strategy based on the weather forecast (with HovalConnect option)

Notice

The TopTronic® E control module for operating the basic module district heating/fresh water must be ordered separately!

For further information about the TopTronic® E, see "Controls"

Delivery

- Incl. thermometer, non-return valves, cut-off ball valves on the domestic water side
- All fittings required for operation, such as strainers, flow balancing and shut-off valves, non-return valves, air vent and drain valve are fitted

Caution

As a result of thermal disinfection of the domestic hot water for legionella protection, increased water temperatures (at least 65 ... 70 °C) occur. Depending on the water quality, this may result in increased calcification at the installed fittings and heat exchangers and also brings the risk of scalding at the tapping points. Corresponding protective measures must be implemented on site.

Calorifier fresh water module

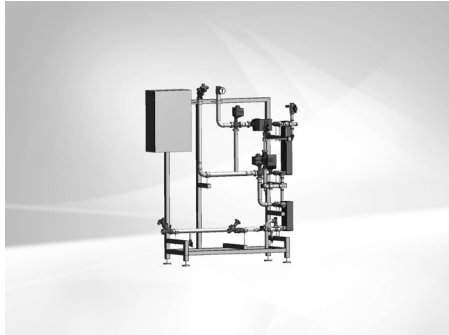

Delivery time on request

TransTherm® aqua FS

Fully assembled station with 2 plate heat exchangers for the provision of domestic hot water using the continuous flow principle and built-in Hoval TopTronic® E control. The buffer storage tanks required for this are not included in the scope of delivery.

TransTherm® aqua FS	Output kW
(7-10)	50
(7-16)	90
(7-20)	130
(7-30)	175
(7-40)	220
(7-50)	275
(7-60)	358
(7-70)	453
(7-80)	569
(7-90)	717

Part No.

8008 017
8008 018
8008 019
8008 020
8008 021
8008 022
8008 023
8008 024
8008 025
8008 026

Version with copper-free heat exchanger

Delivery time on request

TransTherm® aqua FS

with copper-free heat exchanger

TransTherm® aqua FS	Output kW
(7-10)	50
(7-16)	90
(7-20)	130
(7-30)	175
(7-40)	220

8008 027
8008 028
8008 029
8008 030
8008 031

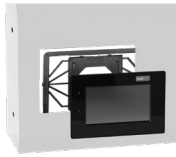

TopTronic® E control module black with 4.3" colour touchscreen

For operation of all controller modules connected to the bus system (basic, solar, buffer modules etc.)
 Connection to the Hoval bus system via RJ45 plug connection or via plug terminals (max. 0.75 mm²), flat design with flexible installation option

Installation:

- in control panel of the heat generator
- in the Hoval wall casing
- in the control panel front, black high-gloss cover, customer-specific configurable start screen, Display of current weather or weather forecast (only possible in combination with HovalConnect)

Consisting of:

- TopTronic® E control module black
- Clamping device set control module
- RJ45-RAST 5 CAN cable, L = 500

Part No.

6043 844



Test valve DN 8 G 1/4"

for TransTherm® aqua L, L-FW, F, FS
 Test valve suitable for flame treatment for hygienic-microbiologic tests.

2049 861



Sludge separator DM with magnet

made of technopolymer (PO) or brass with insulation (MS)

Type	Connection	Flow rate at 1.2 m/s flow speed	k _v value	
	inches	m ³ /h	m ³ /h	
DM PO	Rp 1"	1.3	10.5	2054 376
DM PO	Rp 1 1/4"	2.1	10.5	2085 523
DM MS	Rp 1 1/2"	5.4	63.2	2085 527
DM MS	Rp 2"	8.2	70.0	2085 528

Additional sludge separators
 see "Various system components"



Insulation for sludge separator DM PO 1"

10 mm insulating caps made of PE-X foam
 Thermal conductivity 0.035 W/mK
 Fire resistance (DIN 4102): class B2





2085 524



Insulation for sludge separator DM PO 1 1/4"

10 mm insulating caps made of PE-X foam
 Thermal conductivity 0.035 W/mK
 Fire resistance (DIN 4102): class B2

2086 031

		Part No.
	<p>Temperature monitor 0 ... 120 °C for TransTherm® aqua L, L-FW, F, FS</p>	2048 299
	<p>Safety temperature monitor 70 ... 130 °C for TransTherm® aqua L, L-FW, F, FS</p>	2048 300
	<p>Safety temperature limiter 70 ... 130 °C for TransTherm® aqua L, L-FW, F, FS</p>	2049 619
	<p>Immersion sleeve G 1/2" stainless steel for thermostat for TransTherm® aqua L, L-FW, F, FS Installation length = 100 mm Outer Ø: 8 mm, inner Ø: 6.5 mm</p>	2048 285
	<p>Immersion sleeve G 1/2" stainless steel for 2 thermostats for TransTherm® aqua L, L-FW, F, FS Installation length = 100 mm Outer Ø: 15 mm, inner Ø: 13.5 mm</p>	2048 288

Services



Services and associated scope of services
see separate catalogue "Hoval Services"

Commissioning by Hoval customer service is a prerequisite for warranty/guarantee activation.

Performance data

TransTherm® aqua FS (7-10 to 7-50)

Domestic water secondary			Flow temperature heating water												
			55 °C (6-...)						60 °C (6-...)						
			(10)	(16)	(20)	(30)	(40)	(50)	(10)	(16)	(20)	(30)	(40)	(50)	
60/5 °C	T return primary	°C	-	-	-	-	-	-	-	-	-	-	-	-	-
	Ṽ primary	m³/h	-	-	-	-	-	-	-	-	-	-	-	-	-
	Q max.	kW	-	-	-	-	-	-	-	-	-	-	-	-	-
60/10 °C	T return primary	°C	-	-	-	-	-	-	-	-	-	-	-	-	-
	Ṽ primary	m³/h	-	-	-	-	-	-	-	-	-	-	-	-	-
	Q max.	kW	-	-	-	-	-	-	-	-	-	-	-	-	-
60/15 °C	T return primary	°C	-	-	-	-	-	-	-	-	-	-	-	-	-
	Ṽ primary	m³/h	-	-	-	-	-	-	-	-	-	-	-	-	-
	Q max.	kW	-	-	-	-	-	-	-	-	-	-	-	-	-
60/20 °C	T return primary	°C	-	-	-	-	-	-	-	-	-	-	-	-	-
	Ṽ primary	m³/h	-	-	-	-	-	-	-	-	-	-	-	-	-
	Q max.	kW	-	-	-	-	-	-	-	-	-	-	-	-	-
55/5 °C	T return primary	°C	-	-	-	-	-	-	30	30	30	30	30	30	30
	Ṽ primary	m³/h	-	-	-	-	-	-	1.25	2.04	2.51	3.71	4.76	5.66	6.66
	Q max.	kW	-	-	-	-	-	-	43	70	86	127	163	194	235
55/10 °C	T return primary	°C	-	-	-	-	-	-	30	30	30	30	30	30	30
	Ṽ primary	m³/h	-	-	-	-	-	-	1.11	2.04	2.51	3.71	4.76	5.63	6.63
	Q max.	kW	-	-	-	-	-	-	38	70	86	127	163	193	235
55/15 °C	T return primary	°C	-	-	-	-	-	-	30	30	30	30	30	30	30
	Ṽ primary	m³/h	-	-	-	-	-	-	0.76	1.46	1.95	3.06	4.23	5.4	6.6
	Q max.	kW	-	-	-	-	-	-	26	50	67	105	145	185	235
55/20 °C	T return primary	°C	-	-	-	-	-	-	30	30	30	30	30	30	30
	Ṽ primary	m³/h	-	-	-	-	-	-	0.47	0.9	1.17	1.9	2.63	3.36	4.1
	Q max.	kW	-	-	-	-	-	-	16	31	40	65	90	115	148
50/5 °C	T return primary	°C	30	30	30	30	30	30	30	30	30	30	30	30	30
	Ṽ primary	m³/h	1.29	2.03	2.51	3.67	4.72	5.66	1.28	2.04	2.51	3.71	4.76	5.63	6.63
	Q max.	kW	37	58	72	105	135	162	44	70	86	127	163	193	235
50/10 °C	T return primary	°C	30	30	30	30	30	30	30	30	30	30	30	30	30
	Ṽ primary	m³/h	1.29	2.03	2.51	3.67	4.72	5.66	1.28	2.04	2.51	3.73	4.81	5.69	6.69
	Q max.	kW	38	58	72	105	135	162	44	70	86	128	165	195	235
50/15 °C	T return primary	°C	30	30	30	30	30	30	30	30	30	30	30	30	30
	Ṽ primary	m³/h	1.29	2.03	2.51	3.67	4.72	5.66	1.11	1.95	2.48	3.76	4.76	5.69	6.69
	Q max.	kW	37	58	72	105	135	162	38	67	85	129	163	195	235
50/20 °C	T return primary	°C	30	30	30	30	30	30	30	30	30	30	30	30	30
	Ṽ primary	m³/h	1.15	2.03	2.55	3.7	4.75	5.69	0.96	1.69	2.13	3.24	3.63	5.16	6.16
	Q max.	kW	33	58	73	106	136	163	33	58	73	111	145	177	217
45/5 °C	T return primary	°C	19	18	18	18	18	17	177	16	16	16	16	16	15
	Ṽ primary	m³/h	0.86	1.91	2.9	2.9	3.8	4.61	0.86	1.92	2.91	2.91	3.82	4.63	5.63
	Q max.	kW	35	80	123	123	162	199	42	95	145	145	192	235	285
45/10 °C	T return primary	°C	21	21	20	20	20	20	20	19	19	19	18	18	18
	Ṽ primary	m³/h	0.86	1.91	2.89	2.89	3.81	4.62	0.86	1.92	2.84	2.84	3.63	4.32	5.32
	Q max.	kW	33	74	114	114	151	185	39	89	133	133	172	207	257
45/15 °C	T return primary	°C	24	23	23	23	23	23	23	22	21	21	21	21	21
	Ṽ primary	m³/h	0.86	1.91	2.91	2.91	3.81	4.62	0.87	1.8	2.61	2.61	3.33	3.98	4.98
	Q max.	kW	30	69	106	106	139	170	37	78	115	115	148	178	228
45/20 °C	T return primary	°C	27	26	26	26	26	26	25	25	24	24	24	24	24
	Ṽ primary	m³/h	0.86	1.92	2.91	2.91	3.71	4.41	0.85	1.63	2.36	2.36	3.02	3.61	4.61
	Q max.	kW	27	63	96	96	124	148	33	65	96	96	123	148	198

T return primary °C Return temperature primary
 Ṽ primary m³/h Flow rate primary
 Q max. kW Output
 Ṽ secondary m³/h Flow rate secondary

The specified technical data relate to the full load of the module in each case.

Performance data

TransTherm® aqua FS (7-10 to 7-50)

Domestic water secondary			Flow temperature heating water											
			65 °C (6-...)						70 °C (6-...)					
			(10)	(16)	(20)	(30)	(40)	(50)	(10)	(16)	(20)	(30)	(40)	(50)
60/5 °C	T return primary	°C	30	30	30	30	30	30	30	30	30	30	30	30
	V primary	m³/h	1.08	1.88	2.5	3.73	4.84	5.77	1.32	2.09	2.86	3.76	4.49	5.72
	Q max.	kW	43	75	100	149	193	230	60	95	133	171	209	260
	V secondary	m³/h	0.67	1.17	1.55	2.33	3.01	3.59	0.94	1.48	2.29	2.67	3.59	4.06
60/10 °C	T return primary	°C	30	30	30	30	30	30	30	30	30	30	30	30
	V primary	m³/h	0.8	1.5	2.01	3.16	4.34	5.39	1.08	1.94	2.80	3.77	4.73	5.92
	Q max.	kW	32	60	80	126	173	215	50	90	130	175	220	275
	V secondary	m³/h	0.55	1.03	1.38	2.17	2.98	3.7	0.86	1.54	2.24	3.01	3.78	4.73
60/15 °C	T return primary	°C	30	30	30	30	30	30	30	30	30	30	30	30
	V primary	m³/h	0.55	1.05	1.38	2.13	3.08	3.96	0.97	1.8	2.37	3.73	4.84	5.72
	Q max.	kW	22	42	55	85	123	158	44	82	108	170	220	260
	V secondary	m³/h	0.42	0.8	1.05	1.63	2.35	3.02	0.84	1.57	2.08	3.24	4.21	4.98
60/20 °C	T return primary	°C	30	30	30	30	30	30	30	30	30	30	30	30
	V primary	m³/h	0.3	0.6	0.8	1.28	1.75	2.33	0.62	1.14	2.05	2.4	3.43	4.22
	Q max.	kW	12	24	32	51	70	93	28	52	68	109	156	192
	V secondary	m³/h	0.26	0.52	0.69	1.1	1.51	2	0.6	1.12	1.47	2.36	3.36	4.14
55/5 °C	T return primary	°C	30	30	30	30	30	30	30	30	30	30	30	30
	V primary	m³/h	0.8	1.5	2.01	3.16	4.34	5.39	1.08	2.09	2.53	3.74	4.84	5.76
	Q max.	kW	32	60	80	126	173	215	50	95	115	170	220	262
	V secondary	m³/h	0.55	1.03	1.38	2.17	2.98	3.7	0.86	1.63	1.97	2.92	3.78	4.5
55/10 °C	T return primary	°C	30	30	30	30	30	30	30	30	30	30	30	30
	V primary	m³/h	1.3	2.06	2.53	3.71	4.81	5.64	1.08	1.87	2.42	3.74	4.84	5.72
	Q max.	kW	52	82	101	148	192	225	49	85	110	170	220	260
	V secondary	m³/h	0.99	1.57	1.93	2.83	3.67	4.3	0.94	1.62	2.1	3.24	4.21	4.98
55/15 °C	T return primary	°C	30	30	30	30	30	30	30	30	30	30	30	30
	V primary	m³/h	0.97	1.65	2.11	3.71	4.81	5.64	1.1	1.88	2.41	3.74	4.22	5.1
	Q max.	kW	44	75	96	148	192	225	44	75	96	148	192	232
	V secondary	m³/h	0.95	1.61	2.07	3.19	4.13	4.84	0.94	1.62	2.1	3.19	4.21	5
55/20 °C	T return primary	°C	30	30	30	30	30	30	30	30	30	30	30	30
	V primary	m³/h	0.95	1.68	2.13	3.23	4.24	5.14	0.84	1.47	1.87	2.84	3.72	4.51
	Q max.	kW	38	67	85	129	169	205	38	67	85	129	169	205
	V secondary	m³/h	0.94	1.65	2.09	3.18	4.16	5.05	0.94	1.65	2.09	3.18	4.16	5.05
50/5 °C	T return primary	°C	30	30	30	30	30	30	30	30	30	30	30	30
	V primary	m³/h	1.25	2.06	2.53	3.71	4.81	5.64	1.08	1.87	2.42	3.56	4.84	5.72
	Q max.	kW	50	82	101	148	192	225	49	85	110	162	220	260
	V secondary	m³/h	0.95	1.57	1.93	2.83	3.67	4.3	0.94	1.62	2.1	3.09	4.21	4.98
50/10 °C	T return primary	°C	30	30	30	30	30	30	30	30	30	30	30	30
	V primary	m³/h	1.1	1.88	2.41	3.71	4.81	5.64	0.97	1.65	2.11	3.25	4.22	5.1
	Q max.	kW	44	75	96	148	192	225	44	75	96	148	192	232
	V secondary	m³/h	0.95	1.61	2.07	3.19	4.13	4.84	0.95	1.61	2.07	3.19	4.13	5
50/15 °C	T return primary	°C	30	30	30	30	30	30	30	30	30	30	30	30
	V primary	m³/h	0.95	1.68	2.13	3.23	4.24	5.14	0.84	1.47	1.87	2.84	3.72	4.51
	Q max.	kW	38	67	85	129	169	205	38	67	85	129	169	205
	V secondary	m³/h	0.94	1.65	2.09	3.18	4.16	5.05	0.94	1.65	2.09	3.18	4.16	5.05
50/20 °C	T return primary	°C	30	30	30	30	30	30	30	30	30	30	30	30
	V primary	m³/h	0.83	1.45	1.81	2.44	3.63	4.44	0.73	1.28	1.61	2.44	3.19	3.89
	Q max.	kW	33	58	73	111	145	177	33	58	73	111	145	177
	V secondary	m³/h	0.95	1.67	2.1	3.19	4.17	5.09	0.95	1.67	2.1	3.19	4.17	5.09
45/5 °C	T return primary	°C	16	15	14	14	14	14	15	13	13	13	12	12
	V primary	m³/h	0.87	1.83	2.64	2.64	3.38	4.03	0.84	1.62	2.35	2.35	3.01	3.59
	Q max.	kW	48	104	152	152	196	236	52	104	152	152	196	236
	V secondary	m³/h	1.04	2.24	3.27	3.27	4.23	5.07	1.13	2.24	3.28	3.28	4.23	5.07
45/10 °C	T return primary	°C	19	17	17	17	17	16	17	16	16	16	15	15
	V primary	m³/h	0.87	1.69	2.45	2.45	3.13	3.73	0.77	1.49	2.17	2.17	2.78	3.32
	Q max.	kW	45	91	134	134	172	206	46	91	133	133	172	206
	V secondary	m³/h	1.13	2.25	3.30	3.30	4.24	5.09	1.13	2.24	3.29	3.29	4.24	5.09
45/15 °C	T return primary	°C	21	20	20	20	20	19	20	19	19	19	19	19
	V primary	m³/h	0.8	1.55	2.24	2.24	2.87	3.43	0.71	1.36	1.98	1.98	2.54	3.03
	Q max.	kW	39	78	115	115	148	178	40	78	114	114	148	177
	V secondary	m³/h	1.14	2.27	3.31	3.31	4.26	5.11	1.16	2.26	3.30	3.30	4.26	5.10
45/20 °C	T return primary	°C	24	23	23	23	23	23	23	23	22	22	22	22
	V primary	m³/h	0.72	1.4	2.02	2.02	2.59	3.1	0.63	1.22	1.78	1.78	2.29	2.73
	Q max.	kW	33	66	96	96	123	148	33	65	96	96	124	148
	V secondary	m³/h	1.16	2.29	3.32	3.32	4.28	5.13	1.15	2.27	3.32	3.32	4.29	5.13

T return primary °C Return temperature primary
V primary m³/h Flow rate primary
 Q max. kW Output
V secondary m³/h Flow rate secondary
 The specified technical data relate to the full load of the module in each case.

Performance data

TransTherm® aqua FS (7-60 to 7-90)

			Flow temperature heating water											
			52 °C				55 °C				60 °C			
Domestic water secondary	TransTherm® aqua FS		(60)	(70)	(80)	(90)	(60)	(70)	(80)	(90)	(60)	(70)	(80)	(90)
60/5 °C	T return primary	°C	-	-	-	-	-	-	-	-	-	-	-	-
	Ṽ primary	m³/h	-	-	-	-	-	-	-	-	-	-	-	-
	Q max.	kW	-	-	-	-	-	-	-	-	-	-	-	-
	Ṽ secondary	m³/h	-	-	-	-	-	-	-	-	-	-	-	-
60/10 °C	T return primary	°C	-	-	-	-	-	-	-	-	-	-	-	-
	Ṽ primary	m³/h	-	-	-	-	-	-	-	-	-	-	-	-
	Q max.	kW	-	-	-	-	-	-	-	-	-	-	-	-
	Ṽ secondary	m³/h	-	-	-	-	-	-	-	-	-	-	-	-
60/15 °C	T return primary	°C	-	-	-	-	-	-	-	-	-	-	-	-
	Ṽ primary	m³/h	-	-	-	-	-	-	-	-	-	-	-	-
	Q max.	kW	-	-	-	-	-	-	-	-	-	-	-	-
	Ṽ secondary	m³/h	-	-	-	-	-	-	-	-	-	-	-	-
60/20 °C	T return primary	°C	-	-	-	-	-	-	-	-	-	-	-	-
	Ṽ primary	m³/h	-	-	-	-	-	-	-	-	-	-	-	-
	Q max.	kW	-	-	-	-	-	-	-	-	-	-	-	-
	Ṽ secondary	m³/h	-	-	-	-	-	-	-	-	-	-	-	-
55/5 °C	T return primary	°C	-	-	-	-	-	-	-	28	28	28	27	
	Ṽ primary	m³/h	-	-	-	-	-	-	-	7.27	10.06	12.62	15.81	
	Q max.	kW	-	-	-	-	-	-	-	270	370	470	600	
	Ṽ secondary	m³/h	-	-	-	-	-	-	-	4.68	6.42	8.15	10.4	
55/10 °C	T return primary	°C	-	-	-	-	-	-	-	30	29	29	29	
	Ṽ primary	m³/h	-	-	-	-	-	-	-	7.30	9.04	11.82	14.63	
	Q max.	kW	-	-	-	-	-	-	-	255	320	420	530	
	Ṽ secondary	m³/h	-	-	-	-	-	-	-	4.91	6.17	8.09	10.21	
55/15 °C	T return primary	°C	-	-	-	-	-	-	-	30	30	30	30	
	Ṽ primary	m³/h	-	-	-	-	-	-	-	5.20	7.23	9.25	13.01	
	Q max.	kW	-	-	-	-	-	-	-	180	250	320	450	
	Ṽ secondary	m³/h	-	-	-	-	-	-	-	3.90	5.42	6.94	9.75	
55/20 °C	T return primary	°C	-	-	-	-	-	-	-	30	30	30	30	
	Ṽ primary	m³/h	-	-	-	-	-	-	-	3.18	4.34	5.78	7.51	
	Q max.	kW	-	-	-	-	-	-	-	110	150	200	260	
	Ṽ secondary	m³/h	-	-	-	-	-	-	-	2.73	3.72	4.95	6.44	
50/5 °C	T return primary	°C	-	-	-	-	25	25	25	24	22	22	21	21
	Ṽ primary	m³/h	-	-	-	-	7.32	8.93	11.59	14.69	7.17	9.14	11.65	13.93
	Q max.	kW	-	-	-	-	250	310	405	520	315	405	520	630
	Ṽ secondary	m³/h	-	-	-	-	4.82	5.97	7.80	10.02	6.07	7.80	10.02	12.14
50/10 °C	T return primary	°C	-	-	-	-	27	27	27	26	24	24	24	23
	Ṽ primary	m³/h	-	-	-	-	7.17	8.95	11.64	14.45	6.78	8.62	11.52	13.16
	Q max.	kW	-	-	-	-	230	290	380	480	280	360	485	560
	Ṽ secondary	m³/h	-	-	-	-	4.99	6.29	8.24	10.4	6.07	7.80	10.51	12.14
50/15 °C	T return primary	°C	-	-	-	-	29	29	29	28	26	26	26	26
	Ṽ primary	m³/h	-	-	-	-	7.25	9.24	11.63	14.5	6.31	8.10	10.97	12.35
	Q max.	kW	-	-	-	-	215	275	350	445	245	315	430	490
	Ṽ secondary	m³/h	-	-	-	-	5.33	6.81	8.67	11.02	6.07	7.80	10.65	12.14
50/20 °C	T return primary	°C	-	-	-	-	30	30	30	30	30	29	29	29
	Ṽ primary	m³/h	-	-	-	-	5.03	6.59	9.02	11.96	6.00	7.6	10.35	11.6
	Q max.	kW	-	-	-	-	145	190	260	345	210	270	370	420
	Ṽ secondary	m³/h	-	-	-	-	4.20	5.49	7.51	9.97	6.07	7.80	10.69	12.14
45/5 °C	T return primary	°C	21	21	21	20	20	19	19	19	18	18	18	17
	Ṽ primary	m³/h	7.20	8.95	11.53	14.54	6.90	8.77	11.62	13.4	5.77	7.36	10.00	11.26
	Q max.	kW	255	320	415	530	280	360	480	560	280	360	490	560
	Ṽ secondary	m³/h	5.53	6.94	9.00	11.50	6.07	7.80	10.4	12.14	6.07	7.80	10.62	12.14
45/10 °C	T return primary	°C	23	23	23	23	22	22	22	21	20	20	20	19
	Ṽ primary	m³/h	7.12	9.21	11.51	14.45	6.44	8.23	11.13	12.57	5.36	6.86	9.27	7.24
	Q max.	kW	235	305	385	490	245	315	430	490	245	315	430	490
	Ṽ secondary	m³/h	5.82	7.56	9.54	12.14	6.07	7.80	10.65	12.14	6.07	7.80	10.65	12.14
45/15 °C	T return primary	°C	25	25	25	25	25	24	24	24	23	22	22	22
	Ṽ primary	m³/h	6.10	8.03	10.67	13.49	6.01	7.63	10.38	11.63	4.88	6.23	8.51	9.53
	Q max.	kW	190	250	335	420	210	270	370	420	210	270	370	420
	Ṽ secondary	m³/h	5.49	7.23	9.68	12.14	6.07	7.80	10.69	12.14	6.07	7.80	10.69	12.14
45/20 °C	T return primary	°C	25	25	25	25	27	27	27	27	25	25	25	25
	Ṽ primary	m³/h	2.73	3.53	4.66	6.42	5.46	6.97	9.57	10.65	4.37	5.59	7.68	8.57
	Q max.	kW	85	110	145	200	175	225	310	350	175	225	310	350
	Ṽ secondary	m³/h	2.95	3.82	5.03	6.94	6.07	7.80	10.75	12.14	6.07	7.80	10.75	12.14

T return primary °C Return temperature primary
Ṽ primary m³/h Flow rate primary
 Q max. kW Output
Ṽ secondary m³/h Flow rate secondary

The specified technical data relate to the full load of the module in each case.

Performance data

TransTherm® aqua FS (7-60 to 7-90)

Flow temperature heating water

Domestic water secondary	TransTherm® aqua FS	Flow temperature heating water							
		65 °C				70 °C			
		(60)	(70)	(80)	(90)	(60)	(70)	(80)	(90)
60/5 °C	T return primary °C	30	30	30	29	26	26	25	25
	V primary m³/h	7.15	9.17	11.72	14.69	7.42	9.40	11.80	14.64
	Q max. kW	290	370	480	610	375	480	549	760
	V secondary m³/h	4.57	5.83	7.57	9.62	5.91	7.57	9.44	11.98
60/10 °C	T return primary °C	30	30	30	30	28	28	28	27
	V primary m³/h	5.45	6.94	9.41	12.88	7.23	9.29	12.23	15.42
	Q max. kW	220	280	380	520	358	453	569	717
	V secondary m³/h	3.82	4.86	6.59	9.02	6.16	7.80	9.79	12.14
60/15 °C	T return primary °C	30	30	30	30	30	30	30	30
	V primary m³/h	3.72	4.83	6.44	8.67	6.72	8.78	11.73	13.49
	Q max. kW	150	195	260	350	310	405	540	630
	V secondary m³/h	2.89	3.76	5.01	6.74	5.97	7.80	10.4	12.14
60/20 °C	T return primary °C	30	30	30	30	30	30	30	30
	V primary m³/h	2.11	2.85	3.72	4.95	4.34	5.64	7.37	9.97
	Q max. kW	85	115	150	200	200	260	340	460
	V secondary m³/h	1.84	2.49	3.25	4.34	4.34	5.64	7.37	9.97
55/5 °C	T return primary °C	24	24	23	23	22	21	21	21
	V primary m³/h	7.42	9.24	11.64	14.38	6.30	8.03	10.99	12.26
	Q max. kW	350	440	560	700	350	450	620	700
	V secondary m³/h	6.07	7.63	9.71	12.14	6.07	7.80	10.75	12.14
55/10 °C	T return primary °C	26	26	26	25	24	24	24	23
	V primary m³/h	7.06	8.96	11.66	13.66	5.96	7.6	10.25	11.6
	Q max. kW	315	405	530	630	315	405	550	630
	V secondary m³/h	6.07	7.80	10.21	12.14	6.07	7.80	10.6	12.14
55/15 °C	T return primary °C	29	28	28	27	27	26	26	26
	V primary m³/h	6.67	8.48	11.48	12.91	5.62	7.16	9.70	10.96
	Q max. kW	280	360	490	560	280	360	490	560
	V secondary m³/h	6.07	7.80	10.62	12.14	6.07	7.80	10.62	12.14
55/20 °C	T return primary °C	30	30	30	30	29	29	29	28
	V primary m³/h	5.95	7.80	10.4	12.14	5.13	6.64	9.01	10.16
	Q max. kW	240	315	420	490	245	315	430	490
	V secondary m³/h	5.95	7.80	10.4	12.14	6.07	7.80	10.65	12.14
50/5 °C	T return primary °C	20	20	19	19	18	18	17	17
	V primary m³/h	6.06	7.72	10.43	11.77	5.30	6.74	9.05	10.27
	Q max. kW	315	405	550	630	315	405	550	630
	V secondary m³/h	6.07	7.80	10.6	12.14	6.07	7.80	10.6	12.14
50/10 °C	T return primary °C	22	22	22	21	21	20	20	19
	V primary m³/h	5.69	7.28	9.81	11.08	4.90	6.24	8.46	9.57
	Q max. kW	280	360	490	560	280	360	490	560
	V secondary m³/h	6.07	7.80	10.62	12.14	6.07	7.80	10.62	12.14
50/15 °C	T return primary °C	25	25	24	24	23	23	22	22
	V primary m³/h	5.30	6.74	9.14	10.29	4.52	5.76	7.82	8.83
	Q max. kW	245	315	430	490	245	315	430	490
	V secondary m³/h	6.07	7.80	10.65	12.14	6.07	7.80	10.65	12.14
50/20 °C	T return primary °C	27	26	27	26	26	26	25	25
	V primary m³/h	4.84	6.00	8.38	9.43	4.12	5.26	7.16	8.07
	Q max. kW	210	270	370	420	210	270	370	420
	V secondary m³/h	6.07	7.80	10.69	12.14	6.07	7.80	10.69	12.14
45/5 °C	T return primary °C	16	16	16	15	15	14	14	13
	V primary m³/h	4.99	6.34	8.58	9.69	4.39	5.59	7.59	8.58
	Q max. kW	280	360	490	560	280	360	490	560
	V secondary m³/h	6.07	7.80	10.62	12.14	6.07	7.80	10.62	12.14
45/10 °C	T return primary °C	19	18	18	18	17	17	17	16
	V primary m³/h	4.57	5.85	7.92	8.94	4.02	5.13	6.98	7.90
	Q max. kW	245	315	430	490	245	315	430	490
	V secondary m³/h	6.07	7.80	10.65	12.14	6.07	7.80	10.65	12.14
45/15 °C	T return primary °C	21	21	21	20	20	20	20	19
	V primary m³/h	4.15	5.30	7.24	8.15	3.64	4.66	6.37	7.18
	Q max. kW	210	270	370	420	210	270	370	420
	V secondary m³/h	6.07	7.80	10.69	12.14	6.07	7.80	10.69	12.14
45/20 °C	T return primary °C	24	24	24	24	23	23	23	23
	V primary m³/h	3.71	4.75	6.51	7.31	3.24	4.15	5.71	6.42
	Q max. kW	175	225	310	350	175	225	310	350
	V secondary m³/h	6.07	7.80	10.75	12.14	6.07	7.80	10.75	12.14

T return primary °C Return temperature primary
V primary m³/h Flow rate primary
 Q max. kW Output
V secondary m³/h Flow rate secondary

The specified technical data relate to the full load of the module in each case.

Performance data

TransTherm® aqua FS

N	Residential units standard apartment according to DIN 4708	Peak heat demand standard apartment according to DIN 4708 with preparation 10 min	Sum flow rate domestic hot water calculation flow rate according to DIN 4708	Simultaneity factor according to DIN 4708	Peak flow rate (DHW)	Peak flow rate (DHW)	Peak flow rate (DHW)	Peak output (DHW)	Peak flow rate TransTherm® aqua FS (DHW)	Peak flow rate TransTherm® aqua FS (DHW)	Peak flow rate TransTherm® aqua FS (DHW)	DHW calorifier output TransTherm® aqua FS	TransTherm® aqua FS	Required heating water volume at 70/30 °C (40 K)	Required heating water buffer storage tank volume at 70/30 °C (40 K)	Buffer storage tank 2 EnerVal	Required recharging capacity	Required recharging capacity	Required recharging capacity
	Preparation	Σ VR at DHW 60 °C	g	Vs at DHW 60 °C	Vs at DHW 60 °C	Vs at DHW 60 °C	[kW]	Vs at DHW 60 °C	Vs at DHW 60 °C	Vs at DHW 60 °C	Q at HT 70/30 °C DHW 10/60 °C	Type	[m³]	[m³]	Type	Time: 20 min 70/30 °C (40 K)	Time: 30 min 70/30 °C (40 K)	Time: 60 min 70/30 °C (40 K)	
	[Wh]	[l/s]		[l/s]	[l/min]	[m³/h]		[l/s]	[l/min]	[m³/h]	[kW]			[m³]	[m³]		[kW]	[kW]	[kW]
1	5820	0.17	1.00	0.17	10.01	0.60	35	0.24	14.3	0.86	50	(7-10)	0.13	0.16	(200)	23	15	8	
2	11640	0.33	0.680	0.23	13.61	0.82	47	0.24	14.3	0.86	50	(7-10)	0.17	0.22	(200)	31	21	10	
3	17460	0.50	0.544	0.27	16.33	0.98	57	0.43	25.8	1.55	90	(7-16)	0.20	0.27	(200)	37	25	12	
4	23280	0.67	0.466	0.31	18.66	1.12	65	0.43	25.8	1.55	90	(7-16)	0.23	0.30	(200)	42	28	14	
5	29100	0.83	0.415	0.35	20.77	1.25	72	0.43	25.8	1.55	90	(7-16)	0.26	0.34	(200)	47	31	16	
6	34920	1.00	0.377	0.38	22.64	1.36	79	0.43	25.8	1.55	90	(7-16)	0.28	0.37	(200)	51	34	17	
7	40740	1.17	0.349	0.41	24.45	1.47	85	0.43	25.8	1.55	90	(7-16)	0.31	0.40	(300)	55	37	18	
8	46560	1.33	0.349	0.47	27.94	1.68	97	0.62	37.3	2.24	130	(7-20)	0.35	0.45	(300)	63	42	21	
9	52380	1.50	0.308	0.46	27.74	1.66	97	0.62	37.3	2.24	130	(7-20)	0.35	0.45	(300)	63	42	21	
10	58200	1.67	0.292	0.49	29.23	1.75	102	0.62	37.3	2.24	130	(7-20)	0.37	0.47	(300)	66	44	22	
11	64020	1.83	0.279	0.51	30.72	1.84	107	0.62	37.3	2.24	130	(7-20)	0.38	0.50	(300)	70	46	23	
12	69840	2.00	0.268	0.54	32.19	1.93	112	0.62	37.3	2.24	130	(7-20)	0.40	0.52	(500)	73	49	24	
13	75660	2.17	0.258	0.56	33.57	2.01	117	0.62	37.3	2.24	130	(7-20)	0.42	0.55	(500)	76	51	25	
14	81480	2.34	0.249	0.58	34.89	2.09	122	0.62	37.3	2.24	130	(7-20)	0.44	0.57	(500)	79	53	26	
15	87300	2.50	0.242	0.61	36.33	2.18	127	0.62	37.3	2.24	130	(7-20)	0.45	0.59	(500)	82	55	27	
16	93120	2.67	0.235	0.63	37.63	2.26	131	0.62	37.3	2.24	130	(7-20)	0.47	0.61	(500)	85	57	28	
17	98940	2.84	0.228	0.65	38.79	2.33	135	0.84	50.2	3.01	175	(7-30)	0.49	0.63	(500)	88	59	29	
18	104760	3.00	0.223	0.67	40.17	2.41	140	0.84	50.2	3.01	175	(7-30)	0.50	0.65	(500)	91	61	30	
19	110580	3.17	0.217	0.69	41.27	2.48	144	0.84	50.2	3.01	175	(7-30)	0.52	0.67	(500)	94	62	31	
20	116400	3.34	0.212	0.71	42.44	2.55	148	0.84	50.2	3.01	175	(7-30)	0.53	0.69	(500)	96	64	32	
21	122220	3.50	0.208	0.73	43.72	2.62	153	0.84	50.2	3.01	175	(7-30)	0.55	0.71	(500)	99	66	33	
22	128040	3.67	0.204	0.75	44.92	2.70	157	0.84	50.2	3.01	175	(7-30)	0.56	0.73	(500)	102	68	34	
23	133860	3.84	0.200	0.77	46.04	2.76	161	0.84	50.2	3.01	175	(7-30)	0.58	0.75	(500)	104	70	35	
24	139680	4.00	0.196	0.78	47.08	2.82	164	0.84	50.2	3.01	175	(7-30)	0.59	0.77	(500)	107	71	36	
25	145500	4.17	0.193	0.80	48.29	2.90	168	0.84	50.2	3.01	175	(7-30)	0.60	0.78	(500)	110	73	37	
26	151320	4.34	0.190	0.82	49.44	2.97	173	0.84	50.2	3.01	175	(7-30)	0.62	0.80	(500)	112	75	37	
27	157140	4.50	0.187	0.84	50.53	3.03	176	0.84	50.2	3.01	175	(7-30)	0.63	0.82	(500)	115	76	38	
28	162960	4.67	0.184	0.86	51.56	3.09	180	0.84	50.2	3.01	175	(7-30)	0.64	0.84	(500)	117	78	39	
29	168780	4.84	0.181	0.88	52.54	3.15	183	1.05	63.1	3.78	220	(7-40)	0.66	0.85	(800)	119	79	40	
30	174600	5.00	0.179	0.90	53.75	3.22	188	1.05	63.1	3.78	220	(7-40)	0.67	0.87	(800)	122	81	41	
31	180420	5.17	0.176	0.91	54.61	3.28	191	1.05	63.1	3.78	220	(7-40)	0.68	0.89	(800)	124	83	41	
32	186240	5.34	0.174	0.93	55.73	3.34	194	1.05	63.1	3.78	220	(7-40)	0.70	0.91	(800)	126	84	42	
33	192060	5.50	0.172	0.95	56.81	3.41	198	1.05	63.1	3.78	220	(7-40)	0.71	0.92	(800)	129	86	43	
34	197880	5.67	0.170	0.96	57.85	3.47	202	1.05	63.1	3.78	220	(7-40)	0.72	0.94	(800)	131	87	44	
35	203700	5.84	0.168	0.98	58.85	3.53	205	1.05	63.1	3.78	220	(7-40)	0.74	0.96	(800)	133	89	44	
36	209520	6.01	0.166	1.00	59.81	3.59	209	1.05	63.1	3.78	220	(7-40)	0.75	0.97	(800)	136	90	45	
37	215340	6.17	0.164	1.01	60.73	3.64	212	1.05	63.1	3.78	220	(7-40)	0.76	0.99	(800)	138	92	46	
38	221160	6.34	0.163	1.03	61.99	3.72	216	1.05	63.1	3.78	220	(7-40)	0.78	1.01	(800)	141	94	47	
39	226980	6.51	0.161	1.05	62.84	3.77	219	1.05	63.1	3.78	220	(7-40)	0.79	1.02	(800)	143	95	48	
40	232800	6.67	0.159	1.06	63.65	3.82	222	1.05	63.1	3.78	220	(7-40)	0.80	1.03	(800)	144	96	48	
41	238620	6.84	0.158	1.08	64.84	3.89	226	1.31	78.8	4.73	275	(7-50)	0.81	1.05	(1000)	147	98	49	
42	244440	7.01	0.156	1.09	65.58	3.93	229	1.31	78.8	4.73	275	(7-50)	0.82	1.07	(1000)	149	99	50	
43	250260	7.17	0.155	1.11	66.71	4.00	233	1.31	78.8	4.73	275	(7-50)	0.83	1.08	(1000)	151	101	50	
44	256080	7.34	0.154	1.13	67.82	4.07	237	1.31	78.8	4.73	275	(7-50)	0.85	1.10	(1000)	154	103	51	
45	261900	7.51	0.152	1.14	68.46	4.11	239	1.31	78.8	4.73	275	(7-50)	0.86	1.11	(1000)	155	104	52	
46	267720	7.67	0.151	1.16	69.52	4.17	243	1.31	78.8	4.73	275	(7-50)	0.87	1.13	(1000)	158	105	53	
47	273540	7.84	0.150	1.18	70.56	4.23	246	1.31	78.8	4.73	275	(7-50)	0.88	1.15	(1000)	160	107	53	
48	279360	8.01	0.149	1.19	71.58	4.29	250	1.31	78.8	4.73	275	(7-50)	0.89	1.16	(1000)	162	108	54	
49	285180	8.17	0.148	1.21	72.58	4.35	253	1.31	78.8	4.73	275	(7-50)	0.91	1.18	(1000)	165	110	55	
50	291000	8.34	0.146	1.22	73.06	4.38	255	1.31	78.8	4.73	275	(7-50)	0.91	1.19	(1000)	166	110	55	
51	296820	8.51	0.145	1.23	74.01	4.44	258	1.31	78.8	4.73	275	(7-50)	0.93	1.20	(1000)	168	112	56	
52	302640	8.67	0.144	1.25	74.94	4.50	261	1.31	78.8	4.73	275	(7-50)	0.94	1.22	(1000)	170	113	57	
53	308460	8.84	0.143	1.26	75.86	4.55	265	1.31	78.8	4.73	275	(7-50)	0.95	1.23	(1000)	172	115	57	
54	314280	9.01	0.142	1.28	76.75	4.60	268	1.31	78.8	4.73	275	(7-50)	0.96	1.25	(1000)	174	116	58	
55	320100	9.17	0.141	1.29	77.62	4.66	271	1.31	78.8	4.73	275	(7-50)	0.97	1.26	(1000)	176	117	59	

Residential units standard apartment according to DIN 4708	Peak heat demand standard apartment according to DIN 4708 with preparation 10 min	Sum flow rate domestic hot water calculation flow rate according to DIN 4708	Simultaneity factor according to DIN 4708	Peak flow rate (DHW)	Peak flow rate (DHW)	Peak flow rate (DHW)	Peak output (DHW)	Peak flow rate TransTherm® aqua FS (DHW)	Peak flow rate TransTherm® aqua FS (DHW)	Peak flow rate TransTherm® aqua FS (DHW)	DHW calorifier output TransTherm® aqua FS	TransTherm® aqua FS	Required heating water volume at 70/30 °C (40 K)	Required heating water buffer storage tank volume at 70/30 °C (40 K)	Buffer storage tank 2 EnerVal	Required recharging capacity	Required recharging capacity	Required recharging capacity
N	Preparation	∑ VR at DHW 60 °C	g	\dot{V}_s at DHW 60 °C	\dot{V}_s at DHW 60 °C	\dot{V}_s at DHW 60 °C		\dot{V}_s at DHW 60 °C	\dot{V}_s at DHW 60 °C	\dot{V}_s at DHW 60 °C	Q at HT 70/30 °C DHW 10/60 °C	Type			Type	Time: 20 min 70/30 °C (40 K)	Time: 30 min 70/30 °C (40 K)	Time: 60 min 70/30 °C (40 K)
	[Wh]	[l/s]		[l/s]	[l/min]	[m³/h]	[kW]	[l/s]	[l/min]	[m³/h]	[kW]		[m³]	[m³]		[kW]	[kW]	[kW]
56	325920	9.34	0.140	1.31	78.47	4.71	274	1.31	78.8	4.73	275	(7-50)	0.98	1.28	(1000)	178	119	59
57	331740	9.51	0.140	1.33	79.87	4.79	279	1.31	78.8	4.73	275	(7-50)	1.00	1.30	(1000)	181	121	60
58	337560	9.67	0.139	1.34	80.69	4.84	282	1.71	102.6	6.16	358	(7-60)	1.01	1.31	(1000)	183	122	61
59	343380	9.84	0.138	1.36	81.49	4.89	284	1.71	102.6	6.16	358	(7-60)	1.02	1.32	(1000)	185	123	62
60	349200	10.01	0.137	1.37	82.27	4.94	287	1.71	102.6	6.16	358	(7-60)	1.03	1.34	(1000)	187	124	62
61	355020	10.18	0.136	1.38	83.03	4.98	290	1.71	102.6	6.16	358	(7-60)	1.04	1.35	(1000)	188	126	63
62	360840	10.34	0.135	1.40	83.77	5.03	292	1.71	102.6	6.16	358	(7-60)	1.05	1.36	(1000)	190	127	63
63	366660	10.51	0.135	1.42	85.12	5.11	297	1.71	102.6	6.16	358	(7-60)	1.06	1.38	(1000)	193	129	64
64	372480	10.68	0.134	1.43	85.83	5.15	299	1.71	102.6	6.16	358	(7-60)	1.07	1.40	(1000)	195	130	65
65	378300	10.84	0.133	1.44	86.52	5.19	302	1.71	102.6	6.16	358	(7-60)	1.08	1.41	(1000)	196	131	65
66	384120	11.01	0.132	1.45	87.19	5.23	304	1.71	102.6	6.16	358	(7-60)	1.09	1.42	(1000)	198	132	66
67	389940	11.18	0.132	1.48	88.52	5.31	309	1.71	102.6	6.16	358	(7-60)	1.11	1.44	(1000)	201	134	67
68	395760	11.34	0.131	1.49	89.16	5.35	311	1.71	102.6	6.16	358	(7-60)	1.11	1.45	(1000)	202	135	67
69	401580	11.51	0.130	1.50	89.78	5.39	313	1.71	102.6	6.16	358	(7-60)	1.12	1.46	(1000)	204	136	68
70	407400	11.68	0.130	1.52	91.08	5.46	318	1.71	102.6	6.16	358	(7-60)	1.14	1.48	(1000)	207	138	69
71	413220	11.84	0.129	1.53	91.67	5.50	320	1.71	102.6	6.16	358	(7-60)	1.15	1.49	(1000)	208	139	69
72	419040	12.01	0.128	1.54	92.24	5.53	322	1.71	102.6	6.16	358	(7-60)	1.15	1.50	(1500)	209	139	70
73	424860	12.18	0.128	1.56	93.52	5.61	326	1.71	102.6	6.16	358	(7-60)	1.17	1.52	(1500)	212	141	71
74	430680	12.34	0.127	1.57	94.06	5.64	328	1.71	102.6	6.16	358	(7-60)	1.18	1.53	(1500)	213	142	71
75	436500	12.51	0.127	1.59	95.33	5.72	333	1.71	102.6	6.16	358	(7-60)	1.19	1.55	(1500)	216	144	72
76	442320	12.68	0.126	1.60	95.84	5.75	334	1.71	102.6	6.16	358	(7-60)	1.20	1.56	(1500)	217	145	72
77	448140	12.84	0.126	1.62	97.10	5.83	339	1.71	102.6	6.16	358	(7-60)	1.21	1.58	(1500)	220	147	73
78	453960	13.01	0.125	1.63	97.58	5.86	340	1.71	102.6	6.16	358	(7-60)	1.22	1.59	(1500)	221	148	74
79	459780	13.18	0.124	1.63	98.04	5.88	342	1.71	102.6	6.16	358	(7-60)	1.23	1.59	(1500)	222	148	74
80	465600	13.34	0.124	1.65	99.29	5.96	346	1.71	102.6	6.16	358	(7-60)	1.24	1.61	(1500)	225	150	75
81	471420	13.51	0.123	1.66	99.72	5.98	348	1.71	102.6	6.16	358	(7-60)	1.25	1.62	(1500)	226	151	75
82	477240	13.68	0.123	1.68	100.95	6.06	352	1.71	102.6	6.16	358	(7-60)	1.26	1.64	(1500)	229	153	76
83	483060	13.85	0.122	1.69	101.35	6.08	354	1.71	102.6	6.16	358	(7-60)	1.27	1.65	(1500)	230	153	77
84	488880	14.01	0.122	1.71	102.57	6.15	358	1.71	102.6	6.16	358	(7-60)	1.28	1.67	(1500)	233	155	78
85	494700	14.18	0.121	1.72	102.94	6.18	359	1.71	102.6	6.16	358	(7-60)	1.29	1.67	(1500)	233	156	78
86	500520	14.35	0.121	1.74	104.15	6.25	363	2.16	129.9	7.79	453	(7-70)	1.30	1.69	(1500)	236	157	79
87	506340	14.51	0.120	1.74	104.49	6.27	365	2.16	129.9	7.79	453	(7-70)	1.31	1.70	(1500)	237	158	79
88	512160	14.68	0.120	1.76	105.69	6.34	369	2.16	129.9	7.79	453	(7-70)	1.32	1.72	(1500)	240	160	80
89	517980	14.85	0.120	1.78	106.89	6.41	373	2.16	129.9	7.79	453	(7-70)	1.34	1.74	(1500)	242	162	81
90	523800	15.01	0.119	1.79	107.19	6.43	374	2.16	129.9	7.79	453	(7-70)	1.34	1.74	(1500)	243	162	81
91	529620	15.18	0.119	1.81	108.38	6.50	378	2.16	129.9	7.79	453	(7-70)	1.36	1.76	(1500)	246	164	82
92	535440	15.35	0.118	1.81	108.65	6.52	379	2.16	129.9	7.79	453	(7-70)	1.36	1.77	(1500)	246	164	82
93	541260	15.51	0.118	1.83	109.83	6.59	383	2.16	129.9	7.79	453	(7-70)	1.37	1.79	(1500)	249	166	83
94	547080	15.68	0.117	1.83	110.07	6.60	384	2.16	129.9	7.79	453	(7-70)	1.38	1.79	(1500)	250	166	83
95	552900	15.85	0.117	1.85	111.25	6.67	388	2.16	129.9	7.79	453	(7-70)	1.39	1.81	(2000)	252	168	84
96	558720	16.01	0.117	1.87	112.42	6.74	392	2.16	129.9	7.79	453	(7-70)	1.41	1.83	(2000)	255	170	85
97	564540	16.18	0.116	1.88	112.62	6.76	393	2.16	129.9	7.79	453	(7-70)	1.41	1.83	(2000)	255	170	85
98	570360	16.35	0.116	1.90	113.78	6.83	397	2.16	129.9	7.79	453	(7-70)	1.42	1.85	(2000)	258	172	86
99	576180	16.51	0.116	1.92	114.94	6.90	401	2.16	129.9	7.79	453	(7-70)	1.44	1.87	(2000)	261	174	87
100	582000	16.68	0.115	1.92	115.10	6.91	402	2.16	129.9	7.79	453	(7-70)	1.44	1.87	(2000)	261	174	87

Residual overpressure / V domestic hot water circulation > draw-off standby

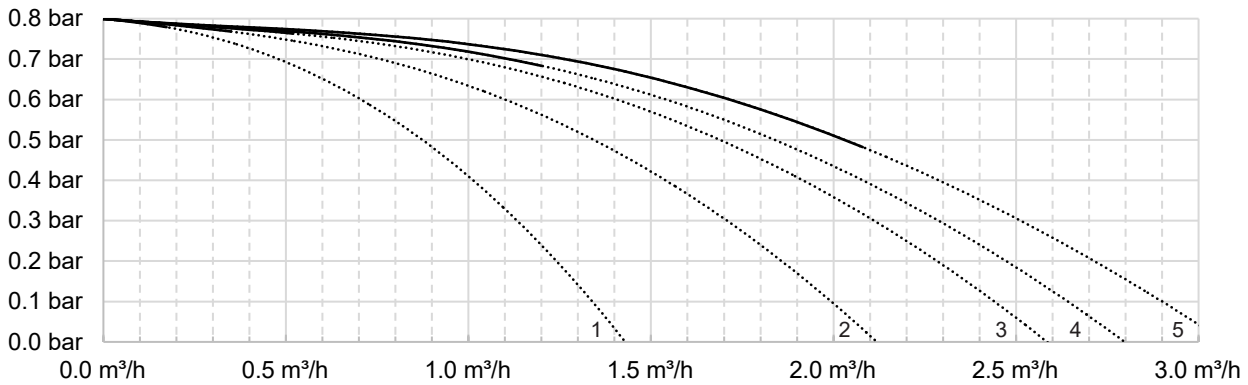

- 1 (7-10)
- 2 (7-16)
- 3 (7-20)
- 4 (7-30)
- 5 (7-40)

Residual overpressure / domestic hot water circulation > with draw-off Vs

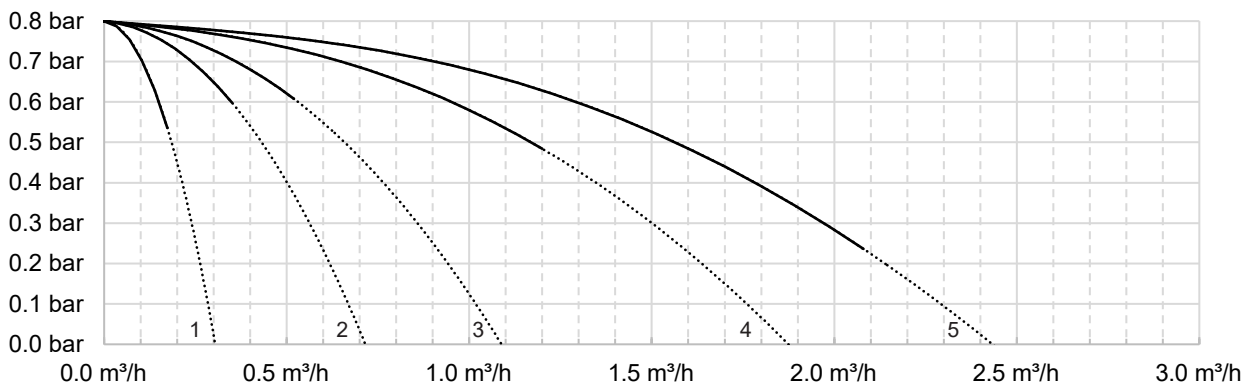

- 1 (7-10)
- 2 (7-16)
- 3 (7-20)
- 4 (7-30)
- 5 (7-40)

Residual overpressure / V domestic hot water circulation > draw-off standby

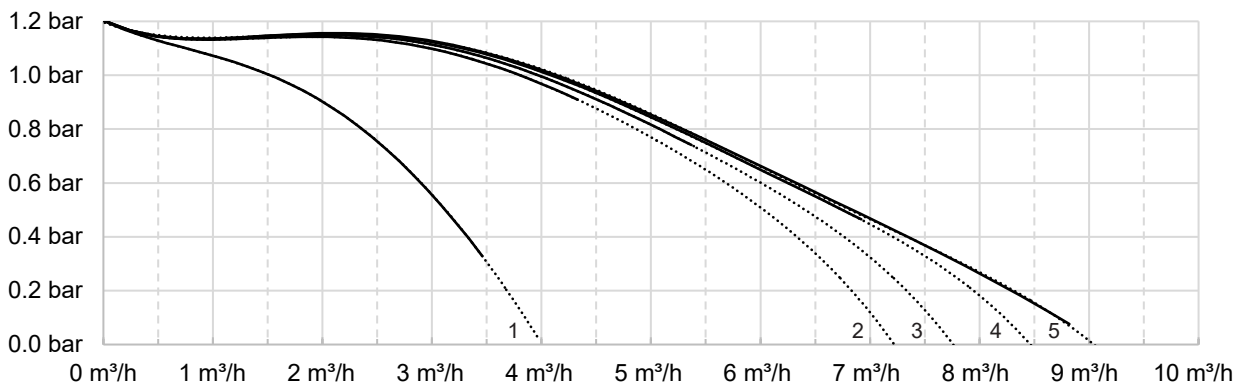

- 1 (7-50)
- 2 (7-60)
- 3 (7-70)
- 4 (7-80)
- 5 (7-90)

Residual overpressure / domestic hot water circulation > with draw-off Vs

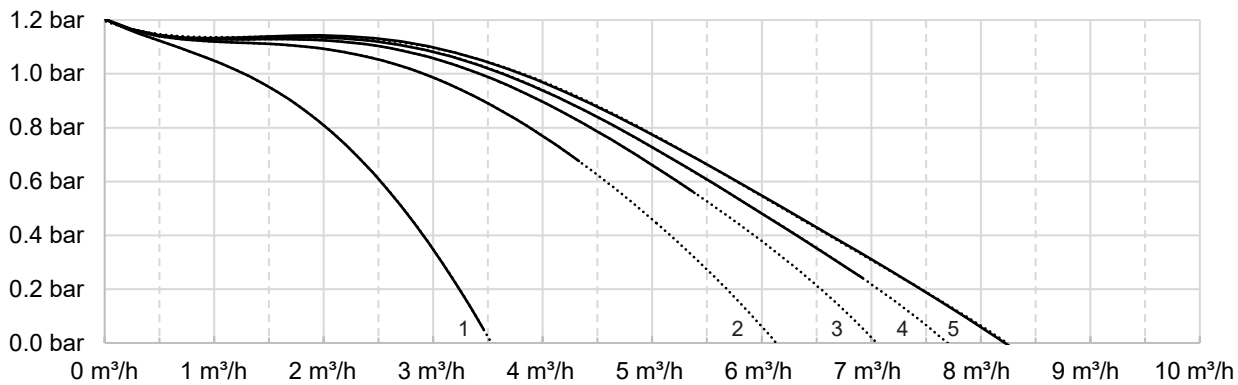

- 1 (7-50)
- 2 (7-60)
- 3 (7-70)
- 4 (7-80)
- 5 (7-90)

All values with open line balancing valve
 Dotted lines = values above nominal performance range

$\Delta P / V$ max / cold water > domestic hot water

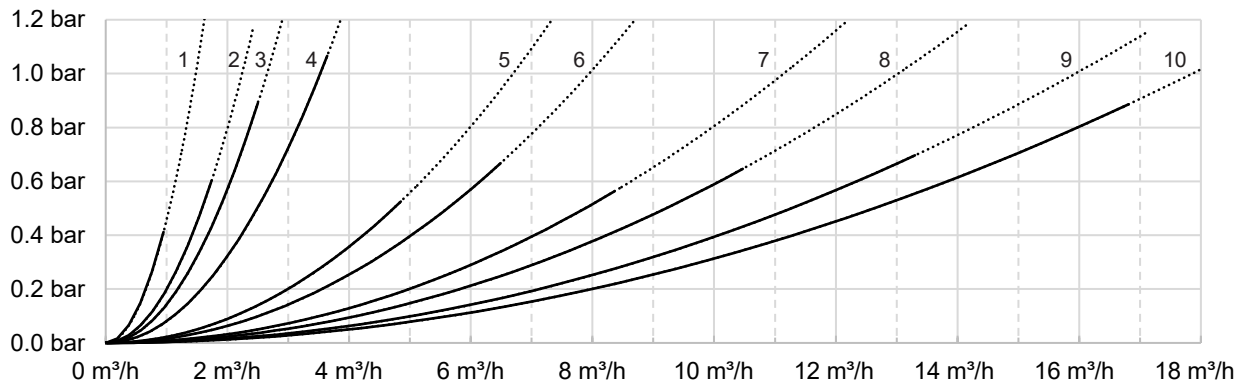

- 1 (7-10)
- 2 (7-16)
- 3 (7-20)
- 4 (7-30)
- 5 (7-40)
- 6 (7-50)
- 7 (7-60)
- 8 (7-70)
- 9 (7-80)
- 10 (7-90)

Residual overpressure / charging circuit flow HT

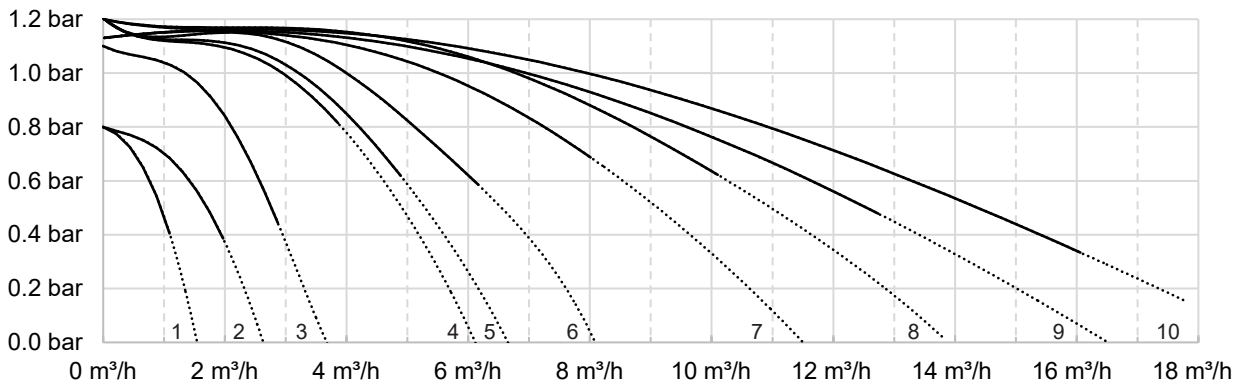

- 1 (7-10)
- 2 (7-16)
- 3 (7-20)
- 4 (7-30)
- 5 (7-40)
- 6 (7-50)
- 7 (7-60)
- 8 (7-70)
- 9 (7-80)
- 10 (7-90)

Residual overpressure / charging circuit flow LT

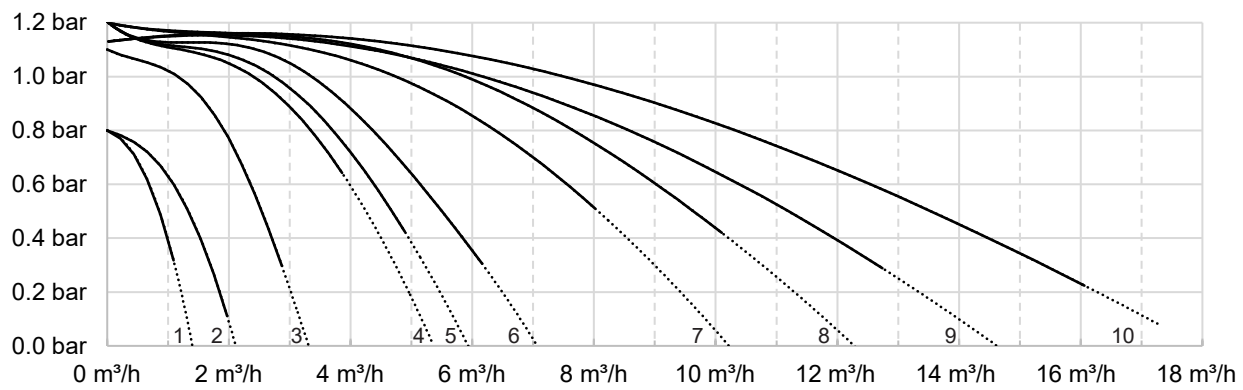

- 1 (7-10)
- 2 (7-16)
- 3 (7-20)
- 4 (7-30)
- 5 (7-40)
- 6 (7-50)
- 7 (7-60)
- 8 (7-70)
- 9 (7-80)
- 10 (7-90)

All values with open line balancing valve
 Dotted lines = values above nominal performance range

Fresh water module TransTherm® aqua FS (7-10 to 7-50)
(Dimensions in mm)

FS (7-10) approx. 1500
FS (7-16), (7-20), (7-30) approx. 1550
FS (7-40) approx. 1650
FS (7-50) approx. 1750

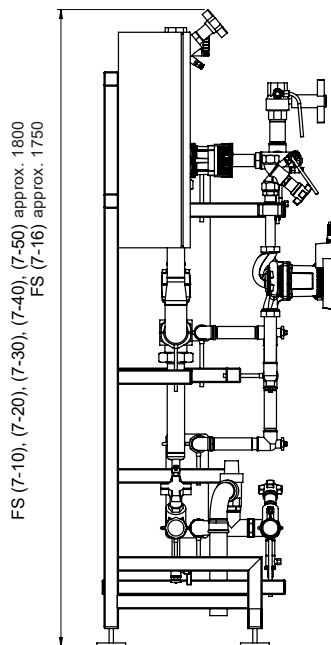
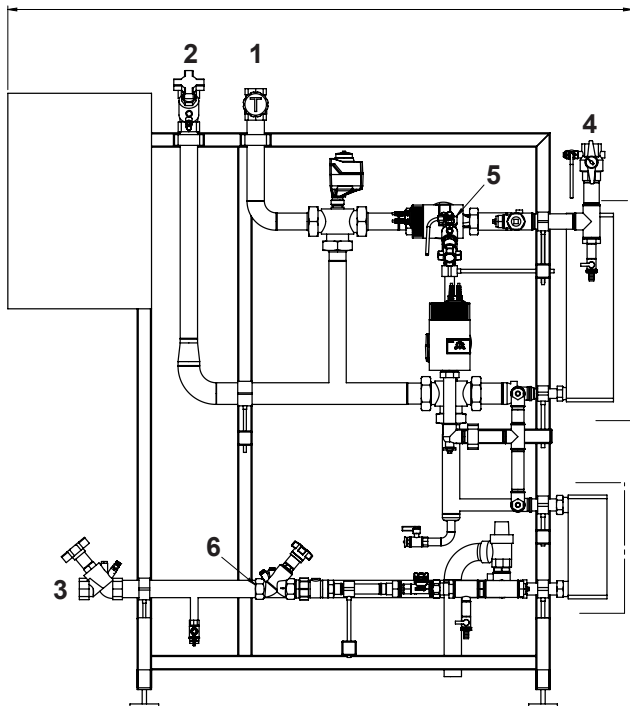

FS (7-10), (7-20), (7-30), (7-40), (7-50) approx. 1800
FS (7-16) approx. 1750

FS (7-10), (7-16), (7-20), (7-30), (7-40) approx. 650
FS (7-50) approx. 700

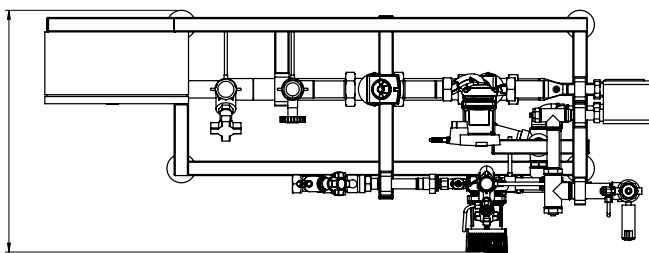

	(7-10)	(7-16)	(7-20) (7-30)	(7-40)	(7-50)
1 Charging circuit FL	DN 20, Rp 3/4"	DN 25, Rp 1"	DN 32, Rp 1 1/4"	DN 32, Rp 1 1/4"	DN 40, Rp 1 1/2"
2 Charging circuit HT RT	DN 20, Rp 3/4"	DN 25, Rp 1"	DN 32, Rp 1 1/4"	DN 32, Rp 1 1/4"	DN 40, Rp 1 1/2"
3 Charging circuit LT RT	DN 20, Rp 3/4"	DN 25, Rp 1"	DN 32, Rp 1 1/4"	DN 32, Rp 1 1/4"	DN 40, Rp 1 1/2"
4 Domestic hot water	DN 20, Rp 3/4"	DN 20, Rp 3/4"	DN 25, Rp 1"	DN 32, Rp 1 1/4"	DN 32, Rp 1 1/4"
5 Domestic hot water circulation	DN 20, Rp 3/4"	DN 20, Rp 3/4"	DN 20, Rp 3/4"	DN 25, Rp 1"	DN 25, Rp 1"
6 Cold water	DN 20, Rp 3/4"	DN 20, Rp 3/4"	DN 25, Rp 1"	DN 32, Rp 1 1/4"	DN 32, Rp 1 1/4"

Rp = Internal thread

Fresh water module TransTherm® aqua FS (7-60 to 7-90)
(Dimensions in mm)

FS (7-60) approx. 2050
 FS (7-70) approx. 2100
 FS (7-80) approx. 2400
 FS (7-90) approx. 2450

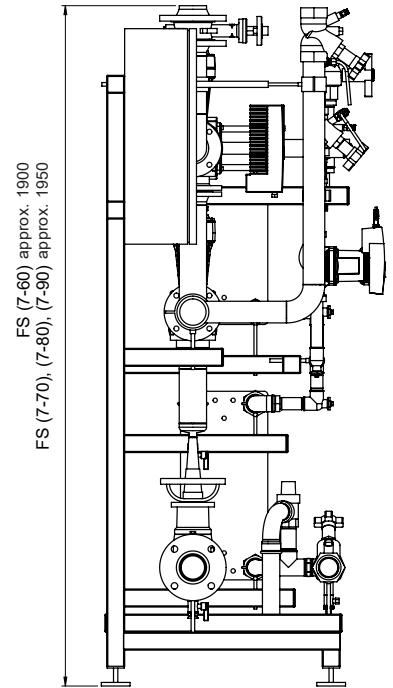
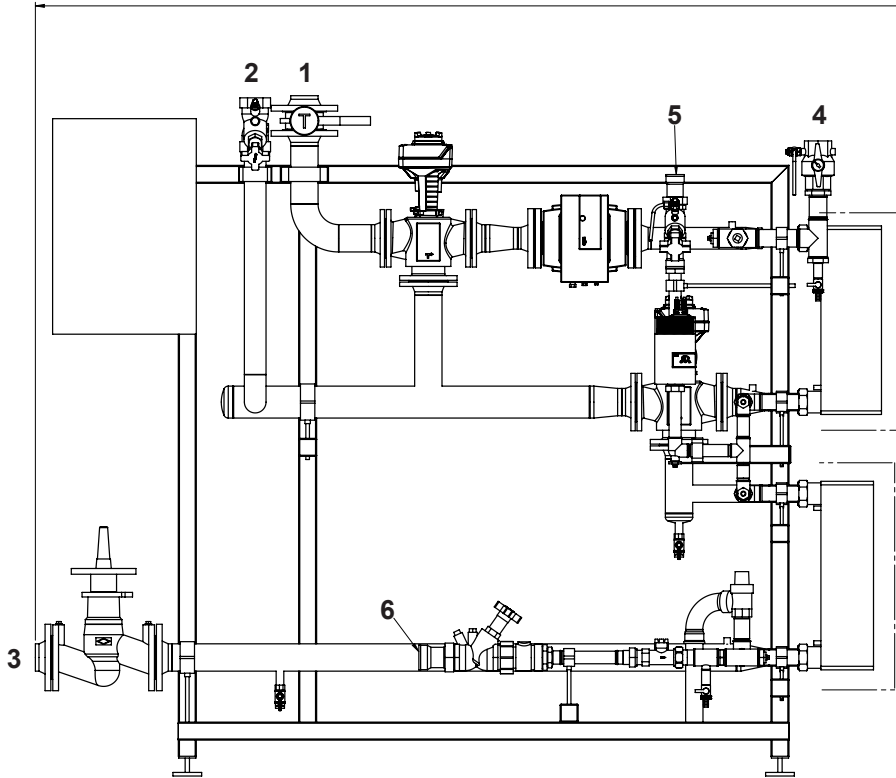

FS (7-60) approx. 1900
 FS (7-70), (7-80), (7-90) approx. 1950

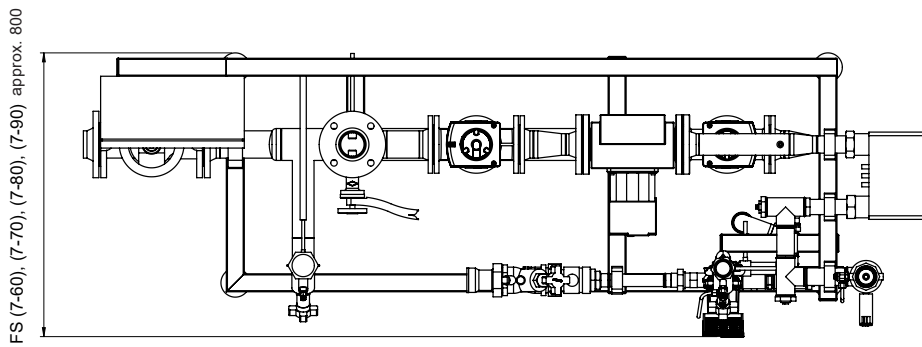

FS (7-60), (7-70), (7-80), (7-90) approx. 800

	(7-60) (7-70)	(7-80) (7-90)
1 Charging circuit FL	DN 50, Rp 2" (IT)	DN 65, Rp 2½" (IT)
2 Charging circuit HT RT	DN 50, Rp 2" (IT)	DN 65, Rp 2½" (IT)
3 Charging circuit LT RT	DN 50, Rp 2" (IT)	DN 65, Rp 2½" (IT)
4 Domestic hot water	DN 40, Rp 1½" (IT)	DN 50, Rp 2" (IT)
5 Domestic hot water circulation	DN 32, Rp 1¼" (IT)	DN 40, Rp 1½" (IT)
6 Cold water	DN 40, Rp 1½" (IT)	DN 50, Rp 2" (IT)

Water heating
TransTherm® aqua FS

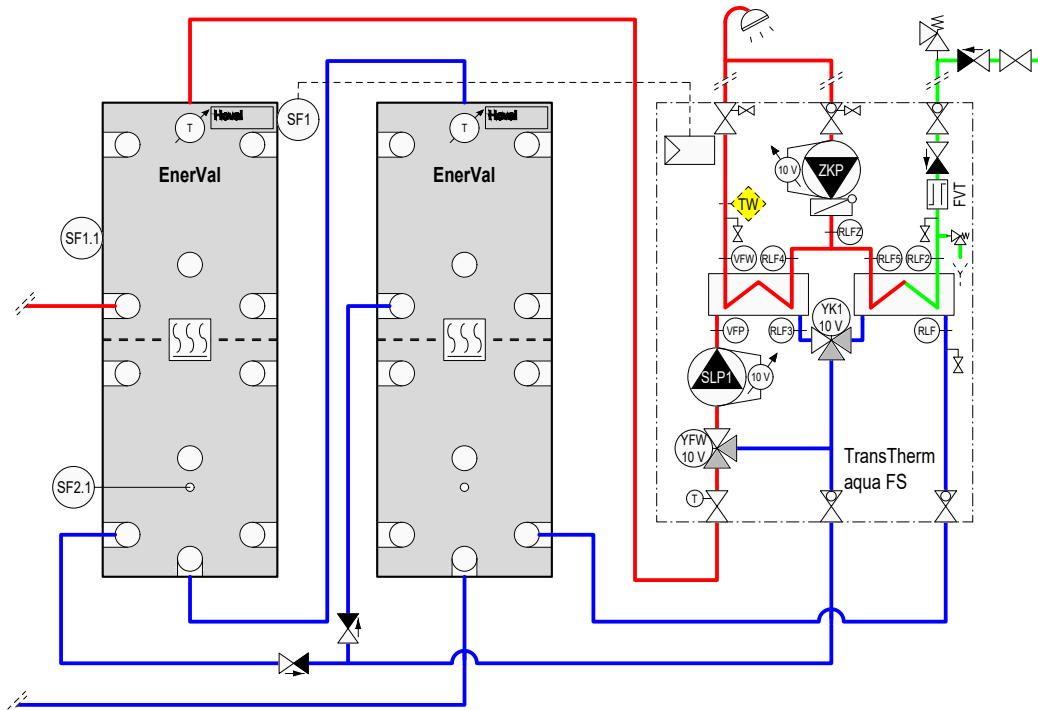

- TTE-FW Basic module district heating/fresh water
- TW Temperature monitor (if required)
- VFW Flow sensor DHW
- RLF4 Return sensor DHW
- RLF5 Return sensor DHW
- RLF2 Return sensor domestic cold water
- RLFZ Return sensor domestic hot water circulation
- SF1 Calorifier sensor
- SF1.1 Calorifier sensor (heat generator)
- SF2.1 Calorifier sensor (heat generator)
- RLFZ Circulation sensor
- FVT Flow rate sensor
- VFP Flow sensor primary
- RLF3 Return sensor HT primary
- RLF Return sensor LT primary
- SLP1 Calorifier charging pump
- YFW Three-way valve with drive (mixing valve)
- YK1 Three-way valve with drive (distributor valve)
- ZKP Circulating pump

Option
BM TopTronic® E control module

Notice

A safety valve (6 bar) must be installed in the cold water line.
The fresh water module is already protected with a safety valve (10 bar).

Hoval quality.
You can count on us.

Hoval is one of the leading international companies for heating and indoor climate solutions. Drawing on more than 80 years of experience and benefiting from a close-knit team culture, the Hoval Group delivers exciting solutions and develops technically superior products. This leadership role requires a sense of responsibility for energy and the environment, which is expressed in an intelligent combination of different heating technologies and customised indoor climate solutions.

Hoval also provides personal consultations and comprehensive customer service. With around 2500 employees in 15 companies around the world, Hoval sees itself not as a conglomerate, but as a large family that thinks and acts globally.

Hoval heating and indoor climate solutions are currently exported to more than 50 countries.

Responsibility for energy and environment

Your Hoval partner

Liechtenstein

Hoval Aktiengesellschaft
9490 Vaduz
+423 399 24 00
hoval.com

United Kingdom

Hoval Ltd.
Newark Notts. NG 24 1JN
+44 1636 672 711
hoval.co.uk

Hoval TransTherm[®] aqua

Fresh water module

TransTherm[®] aqua FT/FTC



Table of contents

■ Description	5
■ Part numbers	6
■ Technical data	8
■ Dimensions	10

Fresh water module

TransTherm® aqua FT/FTC

Fresh water module for hygienic water heating in the continuous flow principle for single- and two-family homes with:

- high-output, soldered stainless steel plate heat exchanger (heat exchanger solder – FT: copper, FTC: stainless steel)
- integrated heating water charging pump
- flow switch for heating water charging pump
- cut-off armatures (optional)
- thermostatic hot water temperature control
- stainless steel piping for quick assembly
- wall attachment
- ready-to-connect
- casing made of sheet steel painted in red or white (optional)
- base plate

The quick-acting hot water temperature sensor accelerates the closing function of the regulating valve and protects the heat exchanger against overheating and scaling.

Output	65 kW (27 l/min)
	57 kW (23 l/min)



Circulation module

for TransTherm® aqua FT (65), FTC (57)

- Pre-assembled, for installation on-site, incl. cable and plug
- Recirculation pump with integrated timer and circulation temperature control, as well as with pre-mounted safety valve (option)

Minimum requirements on water quality for fresh water modules see engineering hot water

Fresh water module

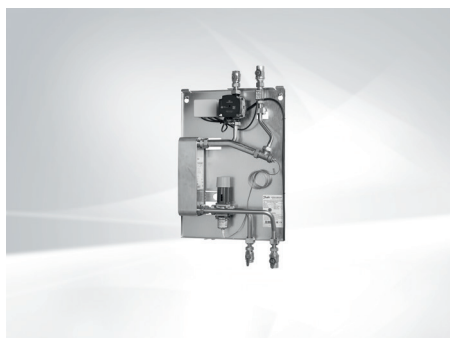

TransTherm® aqua FT/FTC

Fresh water module for hygienic water heating with thermostatic control of the hot water temperature by means of quick-acting water temperature controller

Fresh water module TransTherm® aqua	Output kW
FT (65)	65
FTC (57)	57

Part No.

6040 453
6048 769

Accessories



Ball valve set DVGW
for TransTherm® aqua FT/FTC

6040 456

Casing
for TransTherm® aqua FT/FTC
White colour

6044 175

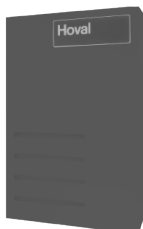

Casing
for TransTherm® aqua FT/FTC
Red colour

6045 319



Circulation heat exchanger lance R 1"
is screwed into the buffer storage tank and integrated into the circulation line.
Material: Copper, tinned inside
Transmission power approx. 1 kW at 60 °C
Hot water temperature in the buffer storage tank without mixing through the storage tank temperature.
Circulation connections R 1/2"
Installation length 660 mm

2038 434

Notice

Circulating pump, safety valve, shut-off valves and non-return flap/valve are missing and must be installed on site.



Circulation module
for TransTherm® aqua FT/FTC preassembled, for subsequent installation on the fresh water module comprising:
Circulation pump with timer switch
Integrated control of the temperature
Non-return flap, ball valve Rp 3/4"
cable and plug,
safety valve 10 bar

6040 455

Services



Services and associated scope of services
see separate catalogue "Hoval Services"

Commissioning by Hoval customer service is a prerequisite for warranty/guarantee activation.

Part No.

TransTherm® aqua FT/FTC

Type		FT (65)	FTC (57)
• Output	kW	65	57
• Connection dimension	Heating flow/return		G 3/4" (ext. thread)
	Cold/hot water		G 3/4" (ext. thread)
• Dimensions (W x H x D)	Without casing		440 x 655 x 140
	With casing		450 x 715 x 150
	With circulation		440/450 x 940 x 140/150
• Weight (incl. packaging)	kg	20	23
• Controller protection class		IP54	IP54
• Supply voltage	V		230
• Plate heat exchanger stainless steel		copper-soldered	soldered stainless steel
Heat exchanger domestic water side			
• Min. static cold water pressure	bar		0.5
• Max. operating pressure	bar		10
• Max. operating temperature	°C		70
Design temperatures domestic water side			
• Cold water	°C		10
• Hot water	°C		45
• Continuous output	l/min	27	23
Heat exchanger heating side			
• Max. operating pressure	bar		10
• Max. permissible operating temperature	°C		100
Design temperatures heating side			
• Heating flow	°C		55
• Heating return	°C		20
• Flow resistance (at V = 1.5 m³/h)	kPa		34

TransTherm® aqua FT (65)
Hot water temperature 45 °C: Tapping capacity – Output – Pressure drops

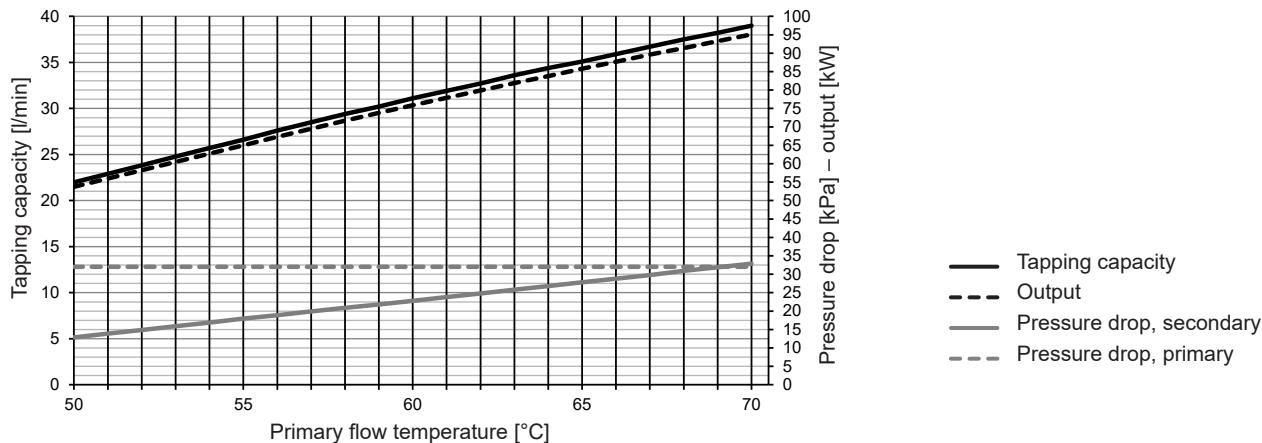

TransTherm® aqua FTC (57)
Hot water temperature 45 °C: Tapping capacity – Output – Pressure drops

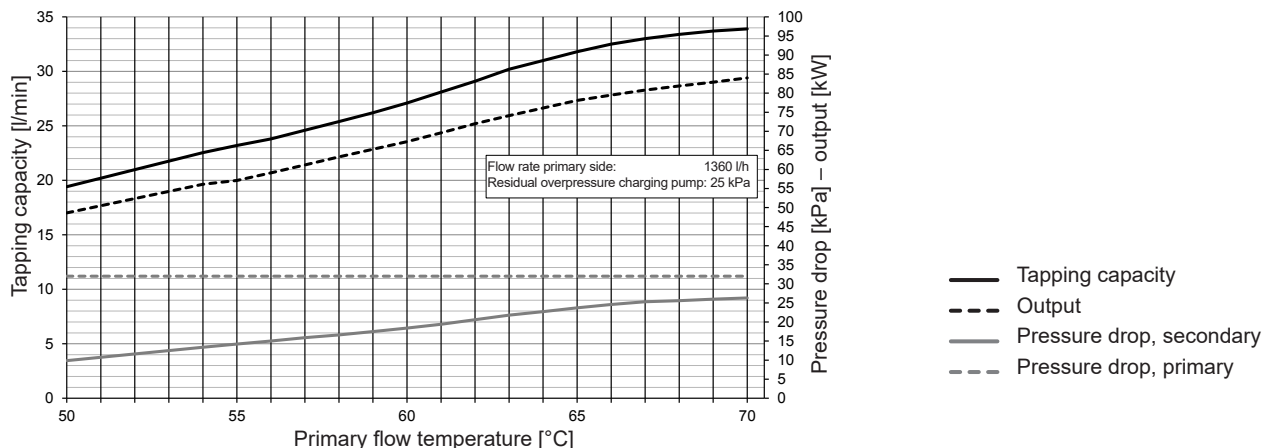

Construction TransTherm® aqua FT/FTC

Buffer storage tank

Fresh water module with circulation module (accessories)

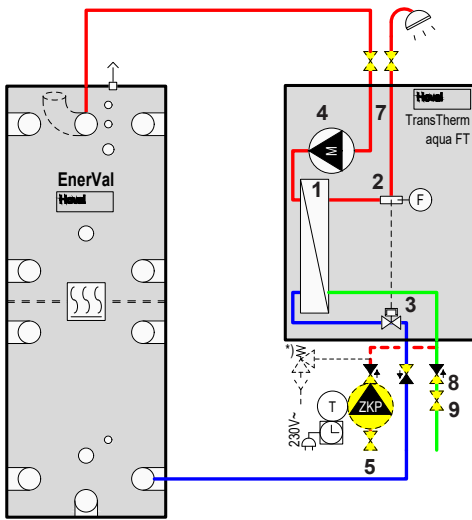

Buffer storage tank

Fresh water module with heat exchanger lance

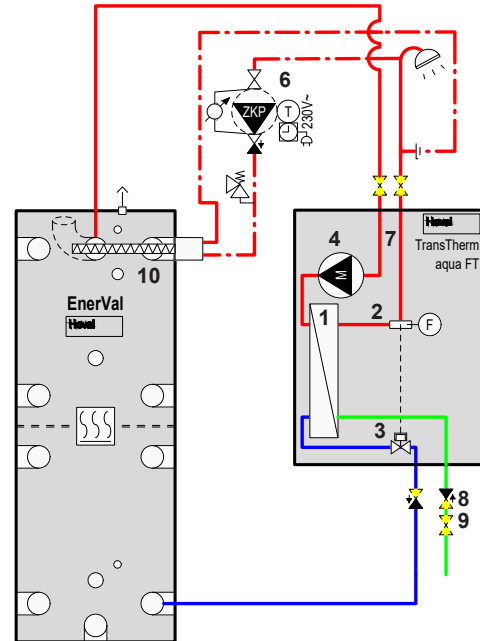

- 1 Stainless steel plate heat exchanger
- 2 Hot water sensor, quick-acting
- 3 Thermostatic control
- 4 Heating water charging pump
- 5 Circulation incl. safety valve (optional)
- 6 Circulation (optional)
- 7 Flow switch
- 8 Non-return valve (optional)
- 9 Cut-off ball valve – flat-sealing (optional)
- 10 Heat exchanger lance

* Safety valve also necessary with recirculation pump on site

Installation of strainer on site

Functional description

Hoval TransTherm® aqua FT/FTC

The Hoval fresh water module TransTherm® aqua FT/FTC, with all piping pre-installed and ready-to-connect, consists of a soldered stainless-steel plate heat exchanger (heat exchanger solder – FT: copper, FTC: stainless steel), an integrated heating water charging pump, a thermostatic controller with tapping detection and hot water temperature control.

When a hot water tapping point is opened, the heating water charging pump is switched on via the flow detection device and the heating water transported from the buffer storage tank to the heat exchanger.

In the large-dimension plate heat exchanger, the hot water is heated in the counterflow principle, directly before removal and in a continuous flow process, from the cold water temperature to the desired DHW temperature.

The quick-acting water temperature controller ensures maintenance of the desired hot water temperature, providing a constant tapping temperature and optimum maintenance of stratification in the buffer storage tank.

An optional recirculation pump with thermostat ensures that the circulating water maintains the desired temperature.

TransTherm® aqua FT/FTC
(Dimensions in mm)

Casing

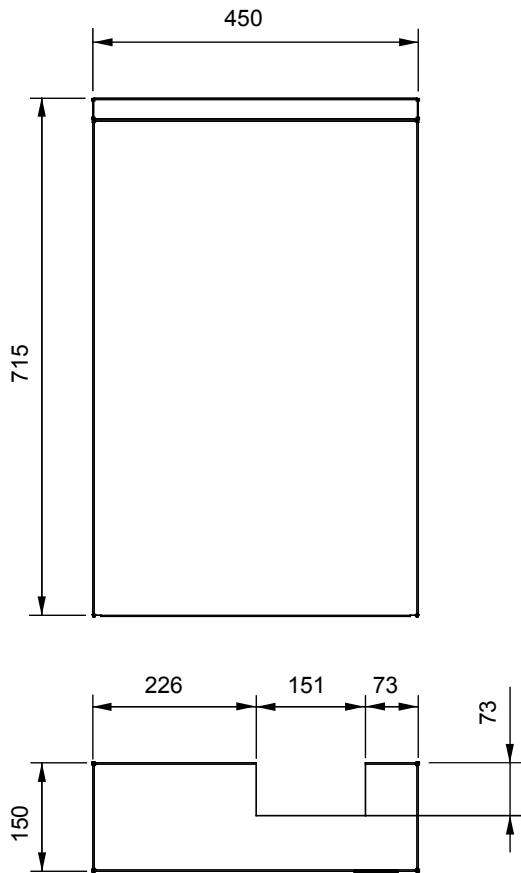

Base plate

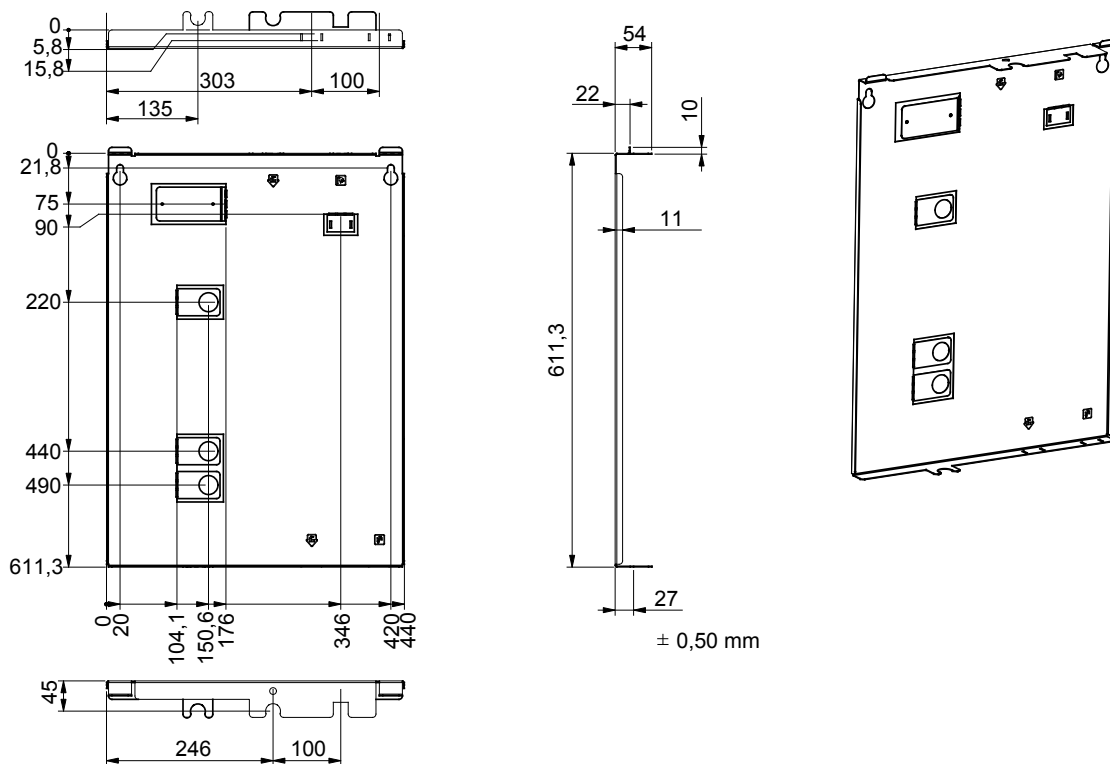

Hoval quality.
You can count on us.

Hoval is one of the leading international companies for heating and indoor climate solutions. Drawing on more than 80 years of experience and benefiting from a close-knit team culture, the Hoval Group delivers exciting solutions and develops technically superior products. This leadership role requires a sense of responsibility for energy and the environment, which is expressed in an intelligent combination of different heating technologies and customised indoor climate solutions.

Hoval also provides personal consultations and comprehensive customer service. With around 2500 employees in 15 companies around the world, Hoval sees itself not as a conglomerate, but as a large family that thinks and acts globally.

Hoval heating and indoor climate solutions are currently exported to more than 50 countries.

Responsibility for energy and environment

Your Hoval partner

Liechtenstein

Hoval Aktiengesellschaft
9490 Vaduz
+423 399 24 00
hoval.com

United Kingdom

Hoval Ltd.
Newark Notts. NG 24 1JN
+44 1636 672 711
hoval.co.uk