

## Hoval UltraGas<sup>®</sup> 2

Floor-standing gas condensing boiler  
UltraGas<sup>®</sup> 2 (125-1550)





**Table of contents**

■ Description	5
■ Part numbers	6
■ Technical data	16
■ Dimensions	22
■ Engineering	28



## Hoval UltraGas® 2 (125-1550)

### Floor-standing gas condensing boiler

- Floor-standing gas condensing boiler
- For the combustion of:
  - natural gas E
  - natural gas E with a hydrogen content (H<sub>2</sub>) of up to 20 % by vol.
  - propane according to DIN 51622
  - biomethane according to EN 16723
- Combustion chamber made of stainless steel
- Maximum flue gas condensation by secondary heating surfaces made of **TurboFer®** hybrid stainless steel composite pipes; heating gas side: stainless steel/aluminium water side: stainless steel
- Thermal insulation with mineral wool mat
- Water pressure sensor:
  - Fulfils the function of a minimum and maximum pressure limiter
  - Replacement for the low water level protection
- Flue gas temperature sensor with flue gas limiter function
- Pre-mix burner
  - with fan and venturi
  - modulating operation
  - automatic ignition
  - ionisation guard
  - gas pressure monitor
- Gas boiler fully clad with steel plates, red powder-coated
- Heating connections backwards incl. counter flange, screws and seals for:
  - heating flow
  - high temperature return
  - low temperature return
- **UltraGas® 2 (300-1550):** with integrated gas pipe compensator
- **TopTronic® E** controller installed
- Possibility of connecting an external gas solenoid valve with error output

### TopTronic® E controller

#### Control panel

- Colour touchscreen 4.3 inch
- Heat generator blocking switch for interrupting operation
- Fault signalling lamp

#### TopTronic® E control module

- Simple, intuitive operating concept
- Display of the most important operating statuses
- Configurable start screen
- Operating mode selection
- Configurable day and week programmes
- Operation of all connected Hoval CAN bus modules
- Commissioning wizard
- Service and maintenance function
- Fault message management
- Analysis function
- Weather display (with HovalConnect option)
- Adaptation of the heating strategy based on the weather forecast (with HovalConnect option)

#### TopTronic® E basic module heat generator TTE-WEZ

- Control functions integrated for
  - 1 heating circuit with mixer
  - 1 heating circuit without mixer
  - 1 hot water charging circuit
  - bivalent and cascade management



### Model range

UltraGas® 2    Nominal heat output  
type            at 50/30 °C  
                         kW

(125)	25-126
(150)	35-151
(190)	38-191
(230)	51-233
(300)	58-299
(350)	70-352
(400)	69-399
(450)	77-451
(500)	77-491
(620)	136-622
(700)	146-703
(800)	166-804
(1000)	205-999
(1100)	229-1112
(1300)	269-1320
(1550)	324-1550
H (700)	146-703
H (1100)	229-1112
H (1550)	324-1550

- Outdoor sensor
- Immersion sensor (calorifier sensor)
- Contact sensor (flow temperature sensor)
- RAST 5 basic plug set

#### Options for TopTronic® E controller

- Can be expanded by max. 1 module expansion:
  - module expansion heating circuit or
  - module expansion heat balancing or
  - module expansion Universal
- Can be networked with a total of up to 16 controller modules:
  - heating circuit/hot water module
  - solar module
  - buffer module
  - measuring module

*Number of modules that can be additionally installed in the heat generator:*

#### UltraGas® 2 (125-230)

- 1 module expansion and 1 controller module **or**
- 2 controller modules

#### UltraGas® 2 (300-500):

- 3 controller modules/module expansions

#### UltraGas® 2 (620-1550):

- 4 controller modules/module expansions

### Notice

Max. 1 module expansion can be connected to the basic module heat generator TTE-WEZ!

The supplementary plug set must be ordered in order to use expanded controller functions.

**Further information about the TopTronic® E** see "Controls"

#### Optional

- With or without neutralisation
- Free-standing calorifier see Calorifiers

#### Delivery

- Boiler, cladding and thermal insulation separately packed and delivered

#### On-site

- Mounting of cladding, thermal insulation and boiler controller
- Mounting of boiler feet

Floor-standing gas condensing boiler

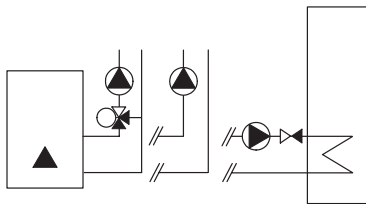

**Hoval UltraGas® 2 (125-1550)**

Floor-standing gas condensing boiler with built-in Hoval TopTronic® E control

- Control functions integrated for
- 1 heating circuit with mixer
  - 1 heating circuit without mixer
  - 1 hot water charging circuit
  - bivalent and cascade management
- Can be optionally expanded by max. 1 module expansion:
    - module expansion heating circuit or
    - module expansion heat balancing or
    - module expansion Universal
  - Can be optionally networked with a total of up to 16 controller modules (incl. solar module)

Boiler made of steel with TopTronic® E control, combustion chamber made of stainless steel. Secondary heating surfaces made of TurboFer® hybrid stainless steel composite pipes. Pre-mix burner with fan. Modulating burner.

*Delivery*

Boiler, cladding and thermal insulation separately packed

**Boiler permissions**

CE product ID No. CE-0085DL0175  
 UltraGas® 2 (125-1550)  
 SVGW No. 20-010-4

UltraGas® 2 type	Nominal heat output at 50/30 °C kW <sup>1)</sup>	Operating pressure bar
(125)	25-126	6
(150)	35-151	6
(190)	38-191	6
(230)	51-233	6
(300)	58-299	6
(350)	70-352	6
(400)	69-399	6
(450)	77-451	6
(500)	77-491	6
(620)	136-622	6
(700)	146-703	6
(800)	166-804	6
(1000)	205-999	6
(1100)	229-1112	6
(1300)	269-1320	6
(1550)	324-1550	6

<sup>1)</sup> kW = modulation range

**Part No.**

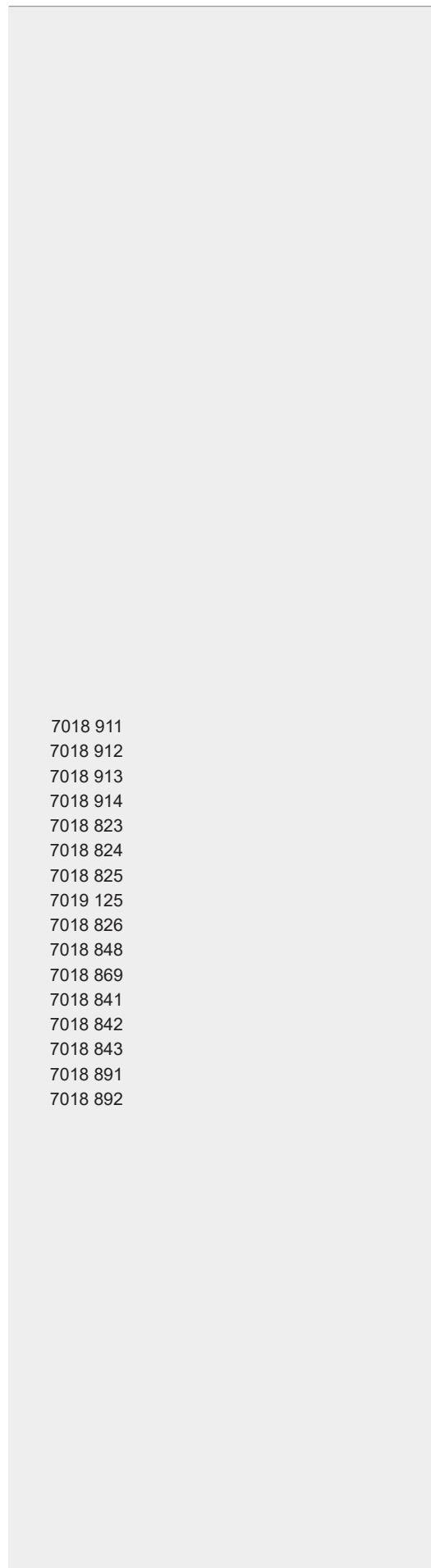

**Floor-standing gas condensing boiler (multi-part installation)**

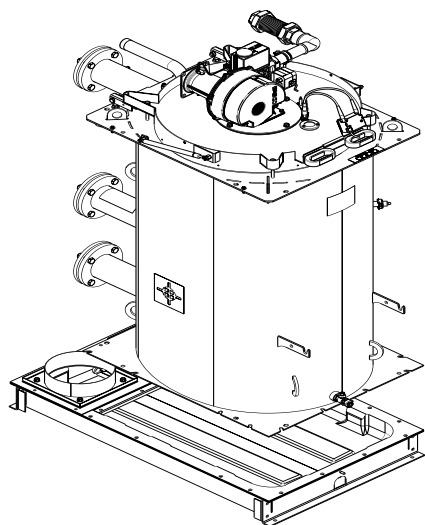

**Hoval UltraGas® 2 (125-1550) (multi-part installation)**

Floor-standing gas condensing boiler with built-in Hoval TopTronic® E control for **multi-part installation**. Assembled on-site by the installer.

UltraGas® 2 type	Nominal heat output 50/30 °C kW	Operating pressure bar
(125)	25-126	6
(150)	35-151	6
(190)	38-191	6
(230)	51-233	6
(300)	58-299	6
(350)	70-352	6
(400)	69-399	6
(450)	77-451	6
(500)	77-491	6
(620)	136-622	6
(700)	146-703	6
(800)	166-804	6
(1000)	205-999	6
(1100)	229-1112	6
(1300)	269-1320	6
(1550)	324-1550	6

<sup>1</sup> kW = modulation range

**Part No.**

7018 909
7018 910
7018 929
7018 930
7018 816
7018 817
7018 818
7019 124
7018 849
7018 864
7018 865
7018 854
7018 855
7018 856
7018 899
7018 900

**Floor-standing gas condensing boiler (high-pressure design)**

Delivery time approx. 8 weeks

**Hoval UltraGas® 2 H (700-1550) (high-pressure design)**

Floor-standing gas condensing boiler in **high-pressure design** (operating pressure 10 bar)

UltraGas® 2 type	Nominal heat output 50/30 °C kW	Operating pressure bar
H (700)	146-703	10
H (1100)	229-1112	10
H (1550)	324-1550	10

<sup>1</sup> kW = modulation range

**Labels for conversion to propane for UltraGas® 2 (125-350)**

6064 576

**Labels for conversion to propane for UltraGas® 2 (400-800)**

6064 578

**Labels for conversion to propane for UltraGas® 2 (1000-1550)**

6064 554

**System flow sensor**

for UltraGas® 2 for installation in the flow connector sleeve Rp ¼", for regulating the flow temperature. Consisting of temperature sensor and connection cable

6053 398



Installation of the system flow sensor is recommended for optimal control of the flow temperature.

**TopTronic® E module expansions**  
for TopTronic® E basic module heat generator

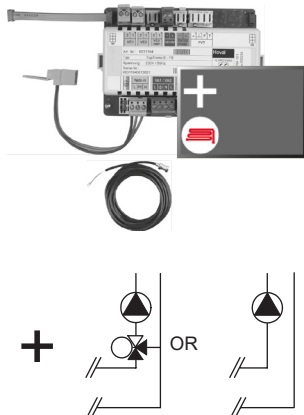

**TopTronic® E module expansion heating circuit TTE-FE HK**

Expansion to the inputs and outputs of the basic module heat generator or the heating circuit/domestic hot water module for implementing the following functions:

- 1 heating/cooling circuit without mixer or
- 1 heating/cooling circuit with mixer

Consisting of:

- Fitting accessories
- 1 contact sensor ALF/2P/4/T, L = 4.0 m
- Basic plug set FE module

**Notice**

The supplementary plug set may have to be ordered to implement functions differing from the standard!

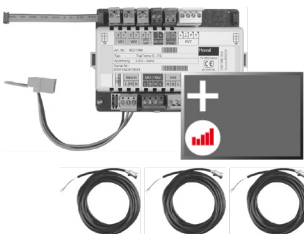

**TopTronic® E module expansion heating circuit incl. energy balancing TTE-FE HK-EBZ**

Expansion to the inputs and outputs of the basic module heat generator or the heating circuit/domestic hot water module for implementing the following functions:

- 1 heating/cooling circuit without mixer or
- 1 heating/cooling circuit with mixer incl. energy balancing in each case

Consisting of:

- Fitting accessories
- 3 contact sensors ALF/2P/4/T, L = 4.0 m
- Plug set FE module

**Notice**

Suitable flow rate sensors (pulse sensors) must be provided on site.

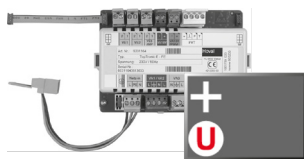

**TopTronic® E module expansion Universal TTE-FE UNI**

Expansion to the inputs and outputs of a controller module (basic module heat generator, heating circuit/domestic hot water module, solar module, buffer module) for implementing various functions

Consisting of:

- Fitting accessories
- Plug set FE module

**Further information**

see "Controls" – "Hoval TopTronic® E module expansions" chapter

**Notice**

Refer to the Hoval System Technology to find which functions and hydraulic arrangements can be implemented.

**Part No.**

6034 576

6037 062

6034 575

Accessories for TopTronic® E

Part No.



**TopTronic® E controller modules**

TTE-HK/WW	TopTronic® E heating circuit/ hot water module	6034 571
TTE-SOL	TopTronic® E solar module	6037 058
TTE-PS	TopTronic® E buffer module	6037 057
TTE-MWA	TopTronic® E measuring module	6034 574



**Supplementary plug set**

	for basic module heat generator TTE-WEZ	6034 499
	for controller modules and module expansion	6034 503
	TTE-FE HK	



**TopTronic® E room control modules**

TTE-RBM	TopTronic® E room control modules	
	easy white	6037 071
	comfort white	6037 069
	comfort black	6037 070



**Enhanced language package TopTronic® E**

one SD card required per control module  
 Consisting of the following languages:  
 HU, CS, SL, RO, PL, TR, ES, HR, SR, JA, DA, NL



**HovalConnect**

HovalConnect LAN	6049 496
HovalConnect WLAN	6049 498
HovalConnect Modbus	6049 501
HovalConnect KNX	6049 593

**TopTronic® E interface modules**

GLT module 0-10 V	6034 578
-------------------	----------

**TopTronic® E sensors**

AF/2P/K	Outdoor sensor	2055 889
	H x W x D = 80 x 50 x 28 mm	
TF/2P/5/6T	Immersion sensor, L = 5.0 m	2055 888
ALF/2P/4/T	Contact sensor, L = 4.0 m	2056 775
TF/1.1P/2.5S/6T	Collector sensor, L = 2.5 m	2056 776



**System module SB-SM-BZ1**

for passing on a volt-free operating  
 and fault message.  
 (for 1-stage/modulating H-Gens)



**Bivalent switch**

	for various release or switching functions	
Bivalent switch 1-piece		2056 858
Bivalent switch 2-piece		2061 826



**System casing**

System casing 182 mm	6038 551
System casing 254 mm	6038 552



**TopTronic® E wall casing**

WG-190	Wall casing small	6052 983
WG-360	Wall casing medium	6052 984
WG-360 BM	Wall casing medium with control module cut-out	6052 985
WG-510	Wall casing large	6052 986
WG-510 BM	Wall casing large with control module cut-out	6052 987



Further information  
 see "Controls"

Accessories



**Flow temperature monitor**  
for panel heating (1 controller per heating circuit) 15 ... 95 °C, setting (visible externally) under the casing cover

**Clamp-on flow temperature monitor RAK-TW1000S**  
with retaining strap, without cable and plug

**Clamp-on flow temperature monitor set RAK-TW1000S**  
with retaining strap, supplied with cable (4 m) and plug

**Immersion thermostat RAK-TW1000S**  
Thermostat with immersion sleeve 1/2"  
Depth of immersion 150 mm,  
nickel-plated brass

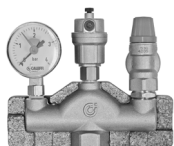

**Safety set DN 25**  
complete with safety valve  
DN 25 (3 bar), up to 200 kW  
Pressure gauge and automatic aspirator with barrier  
Connection: 1" internal thread

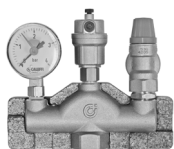

**Safety set DN 32**  
complete with safety valve  
DN 32 (3 bar), up to 350 kW  
Pressure gauge and automatic aspirator with barrier  
Connection 1 1/4" internal thread



Fitting pipe flow

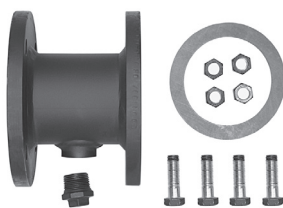

Fitting pipe return

**Safety fitting pipe for flow and return**  
Suitable for max. 6 bar, with screws and nuts.  
- for installation on the flow or high and low-temperature return of the Hoval UltraGas® 2 boiler  
- for installation of an additional safety temperature limiter, a maximum pressure limiter  
- for connection of a diaphragm pressure expansion tank on the return

Dimension	Suitable for UltraGas® 2	Connection
DN 65	(125-230)	flow
DN 65	(125-230)	return
DN 100	(300-700)	flow
DN 100	(300-700)	return
DN 125	(800-1100)	flow
DN 125	(800-1100)	return
DN 150	(1300,1550)	flow
DN 150	(1300,1550)	return

**Further information** see "Dimensions"  
Hoval UltraGas® 2 (125-1550)

Part No.

242 902

6033 745

6010 082

6018 709

6018 710

6053 408

6023 108

6053 409

6023 110

6055 078

6023 112

6055 079

6051 680

Accessories

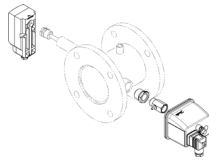

**Safety armature set**  
 Compatible with fitting pipe for meeting safety requirements of EN 12828: > 300 kW or SWKI HE301-01: 70-1000 kW related to single boiler  
 Consisting of:  
 - adjustable maximum pressure limiter incl. ball valve  
 - safety temperature limiter (RAK-ST.131)

Part No.

6051 903



**Hydraulic butterfly valve**  
 for direct installation on the flow and/or return of the boiler pre-wired.  
 Operating method:  
 continuously controlling (2-10 V)

Type

UltraGas® 2 (125-230)	DN 65 / 24 V	6050 605
UltraGas® 2 (300-700)	DN 100 / 24 V	6065 606
UltraGas® 2 (800-1100)	DN 125 / 230 V	6065 607
UltraGas® 2 (1300,1550)	DN 150 / 230 V	6065 608

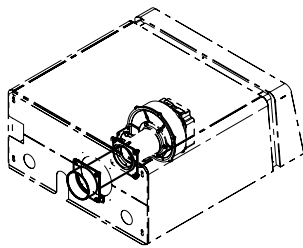

**Connection for direct combustion air supply**  
 Not to be combined with motorised combustion air damper

Type

UltraGas® 2 (125,150)	6052 548
UltraGas® 2 (190,230)	6052 550
UltraGas® 2 (300-500)	6053 096
UltraGas® 2 (620,700)	6053 779
UltraGas® 2 (800-1100)	6053 781
UltraGas® 2 (1300,1550)	6052 844

*Recommendation:*

If the air intake opening at the facade is near a noise sensitive place (window of bedroom, terrace etc.), we recommend to use a silencer at the direct fresh air inlet.

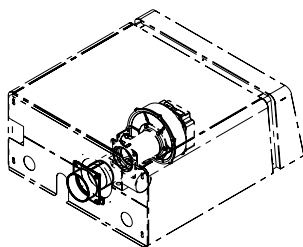

**Connection for direct combustion air supply**  
 Only in combination with a motorised combustion air damper (ordered separately). Can also be used for creating a boiler cascade with a common flue gas line.

Type

UltraGas® 2 (125,150)	6052 847
UltraGas® 2 (190,230)	6052 848
UltraGas® 2 (300-500)	6053 097
UltraGas® 2 (620,700)	6053 780
UltraGas® 2 (800-1100)	6053 782
UltraGas® 2 (1300,1550)	6052 849

Accessories

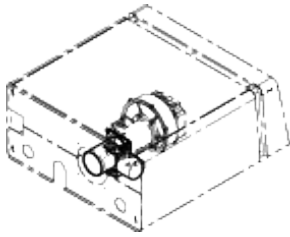

**Motorised combustion air damper DN 110**  
for UltraGas® 2 (125-500)  
For boiler cascades with a common  
flue gas line. Ready-to-connect

6015 196

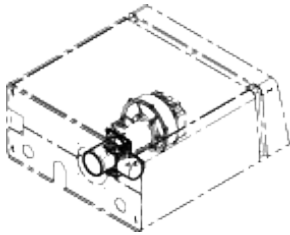

**Motorised combustion air damper DN 180**  
for UltraGas® 2 (620-1550)  
For boiler cascades with a common  
flue gas line. Ready-to-connect

6015 197

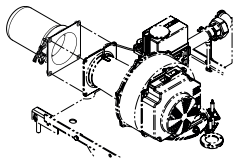

**Connection protection filter**  
for filtering the combustion air in the building  
phase

for installation on the air suction socket:  
UltraGas® 2 (125-500)  
UltraGas® 2 (620-1550)

6052 283

6052 284

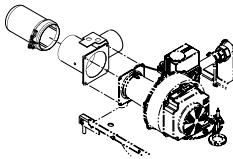

for installation on the combustion air damper:  
UltraGas® 2 (125-500)  
UltraGas® 2 (620-1550)

6052 151

6052 152



**Gas valve**  
with thermally releasing cut-off device.

Type	Connection inches	
DN 25	R 1"	2069 324
DN 32	R 1¼"	2069 325
DN 40	R 1½"	2069 326
DN 50	R 2"	2069 327

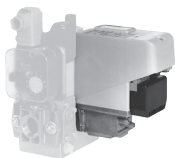

**Valve testing system**  
for UltraGas® 2 (125-1550),  
UltraGas® 2 (250D-3100D)  
Automatic, compact testing system for testing  
the leakage of the gas valve before each burner  
start with ready-to-connect wiring.  
Suitable for all gas qualities for which the  
UltraGas® 2 is permitted.

Type	
UltraGas® 2 (125-350)	6039 964
UltraGas® 2 (400-700)	6039 965
UltraGas® 2 (800-1550)	6054 484

For an UltraGas® 2 double boiler, two valve  
test systems must be ordered.

Accessories

For a kit, the gas ball valve, fitting protection and mounting set must each be ordered separately in the same dimension.



**Gas valve kit**

Set with gas valve and thermally releasing shut-off device  
 Thermal closing at approx. 95 °C  
 Tripping time < 60 s  
 Maximum working pressure 5 bar  
 Ambient temperature < 60 °C  
 Combustible gases according to G260

**Gas ball valve with flange**

Type

DN 65	2007 988
DN 80	2007 989
DN 100	2007 990

**Fitting protection TAS**

Type

TAS 23-65	2069 328
TAS 23-80	2069 329
TAS 23-100	2069 330

**Mounting set for assembly**

**Gas ball valve with fitting protection**

Type

MS-TAS 23-65	6041 745
MS-TAS 23-80	6041 746
MS-TAS 23-100	6041 747

**Gas filter**

with measurement nozzle before and behind the filter inset (diameter: 9 mm)  
 Pore width of the filter inset < 50 µm  
 Max. pressure difference 10 mbar  
 Inlet pressure:  
 UltraGas® 2 (125-700): max. 80 mbar  
 UltraGas® 2 (800-1550): max 300 mbar

Type Connection

70602/6B	Rp 1"	2007 996
70604/6B	Rp 1¼"	2054 495
70603/6B	Rp 1½"	2007 997
70631/6B	Rp 2"	2007 998
70610F/6B	DN 65	2007 999

**Gas pipe compensator 1"**

for UltraGas® 2 (125,150),  
 UltraGas® 2 D (250,300)  
 for compensating for connection tolerances in the gas pipe

6034 556

**Gas pipe compensator 1½"**

for UltraGas® 2 (190,230),  
 UltraGas® 2 D (380,460)  
 for compensating for connection tolerances in the gas pipe

6034 557

Condensate drainage to UltraGas® 2

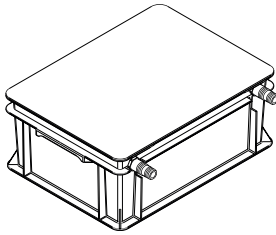

**Neutralisation box**

Condensate drain into a lower drainage duct  
 Connection hose: 2 m  
 Service life up to 1 year, depending on the boiler operating mode  
 Positioning behind the boiler or laterally  
 One neutralisation box per boiler

Type		Neutralisa- tion granulate	
UltraGas® 2 (125-400)	HNB-0400	3 kg	6054 792
UltraGas® 2 (450-800)	HNB-0800	6 kg	6054 793
UltraGas® 2 (1000,1100)	HNB-1200	9 kg	6054 794
UltraGas® 2 (1300,1550)	HNB-1600	12 kg	6054 795



**Condensate pump**

For transporting condensate into a higher drainage duct  
 Including connection lines  
 Completely wired, cable and plug  
 For connection to the boiler controller  
 Delivery head: max. 5 m  
 Can be combined with neutralisation box

6063 855



**Condensate pump**

for UltraGas® 2 (1000-1550)  
 For transporting the condensate into a higher drainage duct  
 Including connection line  
 Completely wired, cable and plug  
 For connection to the boiler controller  
 Delivery head: 4 m  
 Can be combined with neutralisation box

6063 856



**Neutralisation granulate**

for neutralisation box  
 Refill set volume 3 kg  
 Life time of one filling:  
 approx. 1 year, depending on amount of condensate

2028 906

Part No.

Services



**Services and associated scope of services**  
see separate catalogue "Hoval Services"

Commissioning by Hoval customer service  
is a prerequisite for warranty/guarantee ac-  
tivation.

Part No.

Hoval UltraGas® 2 (125-230)

Type		(125)	(150)	(190)	(230)
• Nominal heat output at 80/60 °C, natural gas <sup>1)</sup>	kW	21-114	33-139	35-177	47-218
• Nominal heat output at 50/30 °C, natural gas <sup>1)</sup>	kW	25-126	35-151	38-191	51-233
• Nominal heat output at 80/60 °C, propane <sup>2)</sup>	kW	32-113	43-138	52-175	66-217
• Nominal heat output at 50/30 °C, propane <sup>2)</sup>	kW	35-126	48-151	59-191	73-233
• Nominal heat input with natural gas <sup>3)</sup>	kW	23-116	32-142	35-179	47-223
• Nominal heat input with propane <sup>2)</sup>	kW	33-116	44-142	54-179	68-223
• Operating pressure heating min./max. (PMS)	bar	1/6	1/6	1/6	1/6
• Operating temperature max. (T <sub>max</sub> )	°C	95	95	95	95
• Boiler water content (V <sub>(H2O)</sub> )	l	207	195	276	265
• Flow resistance boiler		see diagram			
• Minimum circulation water quantity	l/h	-	-	-	-
• Boiler weight (without water capacity, incl. cladding)	kg	390	400	485	505
• Boiler efficiency at 80/60 °C in full-load operation (NCV/GCV) <sup>4)</sup>	%	98.6/88.9	97.6/88.1	98.5/88.7	98.2/88.5
• Boiler efficiency at 30 % partial load (NCV/GCV) <sup>4)</sup>	%	108.7/98.1	108.7/98.1	109.0/98.2	108.4/97.8
• Room heating energy efficiency					
- without control	ηs %	93	93	93	93
- with control	ηs %	95	95	95	95
- with control and room sensor	ηs %	97	97	97	97
- annual energy consumption	Q <sub>HE</sub> GJ	209	265	326	412
• NOx class (EN 15502)		-	-	-	-
• Nitrogen oxide emissions (EN 15502) (GCV)	NOx mg/kWh	25	28	33	37
• Carbon monoxide emissions at 50/30 °C (related to 3 % of O <sub>2</sub> )	CO mg/Nm <sup>3</sup>	31	21	25	13
• O <sub>2</sub> content in flue gas min./max. output	%	5.9/5.6	5.5/6.0	5.9/6.0	6.0/5.9
• Heat loss in standby mode (EN 15502) (50°C)	Watt	260	260	320	320
• Dimensions		see dimensional drawing			
• Gas flow pressure min./max.					
- Natural gas E/LL	mbar	17.4-80	17.4-80	17.4-80	17.4-80
- Propane	mbar	37-57	37-57	37-57	37-57
• Gas inlet pressure max. (idle pressure)	mbar	80	80	80	80
• Gas connection values at 15 °C/1013 mbar:					
- Natural gas E – (W <sub>o</sub> = 15.0 kWh/m <sup>3</sup> ) NCV = 9.7 kWh/m <sup>3</sup>	m <sup>3</sup> /h	2.4-12.0	3.3-14.6	3.6-18.5	4.8-23.0
- Natural gas LL (G25) – (W <sub>o</sub> = 12.4 kWh/m <sup>3</sup> ) NCV = 8.13 kWh/m <sup>3</sup>	m <sup>3</sup> /h	2.8-14.3	3.9-17.5	4.3-22.0	5.8-27.4
- Propane (G31) NCV = 24.4 kWh/m <sup>3</sup> <sup>2)</sup>	m <sup>3</sup> /h	1.4-4.8	1.8-5.8	2.2-7.3	2.8-9.1
• Operating voltage (50/60 Hz)	V	1 x 230	1 x 230	1 x 230	1 x 230
• Electrical power consumption min./max.	Watt	41/140	43/225	38/151	49/228
• Standby	Watt	7	8	8	8
• Type of protection	IP	20	20	20	20
• Permitted ambient temperature during operation	°C	5-40	5-40	5-40	5-40
• Sound power level					
- Heating noise (EN 15036 part 1) (room air dependent)	dB(A)	64	69	63	66
- Flue gas noise radiated from the mouth (DIN 45635 part 47) (room air dependent/independent of room air)	dB(A)	69	70	66	68
- Sound pressure level heating noise (reference value depending on installation conditions)	dB(A)	54	59	53	56
• Condensate quantity (natural gas ) at 50/30 °C	l/h	11	12	15	20
• pH value of the condensate (approx.)	pH	4.2	4.2	4.2	4.2
• Construction		B23, B23P, C53, C63			
• Flue gas system					
- Temperature class		T120	T120	T120	T120
- Flue gas mass flow at max. nominal heat input (dry)	kg/h	188	226	283	344
- Flue gas mass flow at min. nominal heat input (dry)	kg/h	37	51	55	63
- Flue gas temperature at max. nominal heat output and 80/60 °C	°C	64	65	68	69
- Flue gas temperature at max. nominal heat output and 50/30 °C	°C	43	45	46	47
- Flue gas temperature at min. nominal heat output and 50/30 °C	°C	29	28	29	29
- Max. permissible temperature of the combustion air	°C	48	48	48	48
- Combustion air flow rate	Nm <sup>3</sup> /h	154	180	232	280
- Maximum supply pressure for combustion air supply and flue gas line	Pa	120	120	130	130
- Maximum draught/underpressure at flue gas outlet	Pa	-30	-30	-30	-30

<sup>1)</sup> In relation to natural gas G20 (100 % methane). With a hydrogen content (H<sub>2</sub>) of up to 20 % by vol. in accordance with DVGW ZP3100 (D), an output reduction of up to 7 % is possible.

<sup>2)</sup> Data related to NCV, conditional data

<sup>3)</sup> Data related to NCV. The boiler series is tested for EE/H setting. With a factory setting to a Wobbe value of 15.0 kWh/m<sup>3</sup>, operation in the Wobbe value range from 12.0 to 15.7 kWh/m<sup>3</sup> is possible without resetting.

<sup>4)</sup> Conversion acc. to EN 15502-1, Appendix J

**Hoval UltraGas® 2 (300-450)**

Type		(300)	(350)	(400)	(450)
• Nominal heat output at 80/60 °C, natural gas <sup>1)</sup>	kW	54-274	67-315	62-362	73-415
• Nominal heat output at 50/30 °C, natural gas <sup>1)</sup>	kW	58-299	70-352	69-399	77-451
• Nominal heat output at 80/60 °C, propane <sup>2)</sup>	kW	83-274	94-311	109-361	124-408
• Nominal heat output at 50/30 °C, propane <sup>2)</sup>	kW	93-299	109-352	123-399	138-451
• Nominal heat input with natural gas <sup>3)</sup>	kW	54-282	64-331	62-374	71-427
• Nominal heat input with propane <sup>2)</sup>	kW	87-282	102-331	114-374	130-427
• Operating pressure heating min./max. (PMS)	bar	1/6	1/6	1/6	1/6
• Operating temperature max. (T <sub>max</sub> )	°C	95	95	95	95
• Boiler water content (V <sub>(H2O)</sub> )	l	472	452	432	412
• Flow resistance boiler		see diagram			
• Minimum circulation water quantity	l/h	-	-	-	-
• Boiler weight (without water capacity, incl. cladding)	kg	730	765	800	830
• Boiler efficiency at 80/60 °C in full-load operation (NCV/GCV) <sup>4)</sup>	%	98.2/88.5	98.2/88.5	98.2/88.5	98.2/88.5
• Boiler efficiency at 30 % partial load (NCV/GCV) <sup>4)</sup>	%	109.2/98.4	108.9/98.1	109.0/98.2	108.9/98.1
• Room heating energy efficiency					
- without control	η <sub>s</sub> %	94	93	93	-
- with control	η <sub>s</sub> %	96	95	95	-
- with control and room sensor	η <sub>s</sub> %	98	97	97	-
- annual energy consumption	Q <sub>HE</sub> GJ	505	590	653	-
• NOx class (EN 15502)		-	-	-	6
• Nitrogen oxide emissions (EN 15502) (GCV)	NOx mg/kWh	39	45	39	45
• Carbon monoxide emissions at 50/30 °C (related to 3 % of O <sub>2</sub> )	CO mg/Nm <sup>3</sup>	18	26	23	30
• O <sub>2</sub> content in flue gas min./max. output	%	5.5/5.8	5.7/5.7	5.9/5.9	6.0/5.6
• Heat loss in standby mode (EN 15502) (50°C)	Watt	430	430	430	430
• Dimensions		see dimensional drawing			
• Gas flow pressure min./max.					
- Natural gas E/LL	mbar	17.4-80	17.4-80	17.4-80	17.4-80
- Propane	mbar	37-57	37-57	37-57	37-57
• Gas inlet pressure max. (idle pressure)	mbar	80	80	80	80
• Gas connection values at 15 °C/1013 mbar:					
- Natural gas E – (W <sub>o</sub> = 15.0 kWh/m <sup>3</sup> ) NCV = 9.7 kWh/m <sup>3</sup>	m <sup>3</sup> /h	5.6-29.1	6.6-34.1	6.4-38.6	7.3-44.0
- Natural gas LL (G25) – (W <sub>o</sub> = 12.4 kWh/m <sup>3</sup> ) NCV = 8.13 kWh/m <sup>3</sup>	m <sup>3</sup> /h	6.6-34.7	7.9-40.7	7.6-46.0	8.7-52.5
- Propane (G31) NCV = 24.4 kWh/m <sup>3</sup> <sup>2)</sup>	m <sup>3</sup> /h	3.6-11.6	4.2-13.6	4.7-15.3	5.3-17.5
• Operating voltage (50/60 Hz)	V	1 x 230	1 x 230	1 x 230	1 x 230
• Electrical power consumption min./max.	Watt	51/365	55/350	56/518	56/590
• Standby	Watt	5	5	5	5
• Type of protection	IP	20	20	20	20
• Permitted ambient temperature during operation	°C	5-40	5-40	5-40	5-40
• Sound power level					
- Heating noise (EN 15036 part 1) (room air dependent)	dB(A)	73	70	73	74
- Flue gas noise radiated from the mouth (DIN 45635 part 47) (room air dependent/independent of room air)	dB(A)	71	72	73	74
- Sound pressure level heating noise (reference value depending on installation conditions)	dB(A)	63	60	63	64
• Condensate quantity (natural gas ) at 50/30 °C	l/h	22	25	28	29
• pH value of the condensate (approx.)	pH	4.2	4.2	4.2	4.2
• Construction		B23, B23P, C53, C63			
• Flue gas system					
- Temperature class		T120	T120	T120	T120
- Flue gas mass flow at max. nominal heat input (dry)	kg/h	445	522	591	674
- Flue gas mass flow at min. nominal heat input (dry)	kg/h	85	101	98	112
- Flue gas temperature at max. nominal heat output and 80/60 °C	°C	64	65	66	67
- Flue gas temperature at max. nominal heat output and 50/30 °C	°C	43	44	48	47
- Flue gas temperature at min. nominal heat output and 50/30 °C	°C	29	29	29	29
- Max. permissible temperature of the combustion air	°C	48	48	48	48
- Combustion air flow rate	Nm <sup>3</sup> /h	364	428	483	552
- Maximum supply pressure for combustion air supply and flue gas line	Pa	130	130	130	130
- Maximum draught/underpressure at flue gas outlet	Pa	-30	-30	-30	-30

<sup>1)</sup> In relation to natural gas G20 (100 % methane). With a hydrogen content (H<sub>2</sub>) of up to 20 % by vol. in accordance with DVGW ZP3100 (D), an output reduction of up to 7 % is possible.

<sup>2)</sup> Data related to NCV, conditional data

<sup>3)</sup> Data related to NCV. The boiler series is tested for EE/H setting. With a factory setting to a Wobbe value of 15.0 kWh/m<sup>3</sup>, operation in the Wobbe value range from 12.0 to 15.7 kWh/m<sup>3</sup> is possible without resetting.

<sup>4)</sup> Conversion acc. to EN 15502-1, Appendix J

**Hoval UltraGas® 2 (500-800)**

Type		(500)	(620)	(700)	(800)
• Nominal heat output at 80/60 °C, natural gas <sup>1)</sup>	kW	71-449	125-580	132-653	150-743
• Nominal heat output at 50/30 °C, natural gas <sup>1)</sup>	kW	77-491	136-622	146-703	166-804
• Nominal heat output at 80/60 °C, propane <sup>2)</sup>	kW	133-441	173-569	193-643	233-744
• Nominal heat output at 50/30 °C, propane <sup>2)</sup>	kW	147-491	184-622	208-703	254-804
• Nominal heat input with natural gas <sup>3)</sup>	kW	71-463	124-591	134-668	151-759
• Nominal heat input with propane <sup>2)</sup>	kW	140-463	179-591	201-668	236-759
• Operating pressure heating min./max. (PMS)	bar	1/6	1/6	1/6	1/6
• Operating temperature max. (T <sub>max</sub> )	°C	95	95	95	95
• Boiler water content (V <sub>(H2O)</sub> )	l	408	536	509	831
• Flow resistance boiler		see diagram			
• Minimum circulation water quantity	l/h	-	-	-	-
• Boiler weight (without water capacity, incl. cladding)	kg	855	1090	1135	1435
• Boiler efficiency at 80/60 °C in full-load operation (NCV/GCV) <sup>4)</sup>	%	98.2/88.5	98.2/88.5	98.2/88.5	98.3/88.6
• Boiler efficiency at 30 % partial load (NCV/GCV) <sup>4)</sup>	%	109.0/98.2	109.0/98.2	108.9/98.1	109.1/98.3
• Room heating energy efficiency					
- without control	ηs %	-	-	-	-
- with control	ηs %	-	-	-	-
- with control and room sensor	ηs %	-	-	-	-
- annual energy consumption	Q <sub>HE</sub> GJ	-	-	-	-
• NOx class (EN 15502)		6	6	6	6
• Nitrogen oxide emissions (EN 15502) (GCV)	NOx mg/kWh	50	33	40	36
• Carbon monoxide emissions at 50/30 °C (related to 3 % of O <sub>2</sub> )	CO mg/Nm <sup>3</sup>	46	24	26	23
• O <sub>2</sub> content in flue gas min./max. output	%	5.5/5.8	5.9/6.0	6.0/5.7	6.0/5.8
• Heat loss in standby mode (EN 15502) (50°C)	Watt	430	540	540	600
• Dimensions		see dimensional drawing			
• Gas flow pressure min./max.					
- Natural gas E/LL	mbar	17.4-80	17.4-80	17.4-80	17.4-300
- Propane	mbar	37-57	37-57	37-57	37-57
• Gas inlet pressure max. (idle pressure)	mbar	80	80	80	300
• Gas connection values at 15 °C/1013 mbar:					
- Natural gas E – (W <sub>o</sub> = 15.0 kWh/m <sup>3</sup> ) NCV = 9.7 kWh/m <sup>3</sup>	m <sup>3</sup> /h	7.3-47.7	12.8-60.9	13.8-68.9	15.6-78.2
- Natural gas LL (G25) – (W <sub>o</sub> = 12.4 kWh/m <sup>3</sup> ) NCV = 8.13 kWh/m <sup>3</sup>	m <sup>3</sup> /h	8.7-56.9	15.3-72.7	16.5-82.2	18.6-93.4
- Propane (G31) NCV = 24.4 kWh/m <sup>3</sup> <sup>2)</sup>	m <sup>3</sup> /h	5.7-19.0	7.3-24.2	8.2-27.4	9.7-31.1
• Operating voltage (50/60 Hz)	V	1 x 230	1 x 230	1 x 230	1 x 230
• Electrical power consumption min./max.	Watt	57/716	63/831	67/1060	94/1012
• Standby	Watt	5	5	5	7
• Type of protection	IP	20	20	20	20
• Permitted ambient temperature during operation	°C	5-40	5-40	5-40	5-40
• Sound power level					
- Heating noise (EN 15036 part 1) (room air dependent)	dB(A)	78	75	76	78
- Flue gas noise radiated from the mouth (DIN 45635 part 47) (room air dependent/independent of room air)	dB(A)	77	72	71	72
- Sound pressure level heating noise (reference value depending on installation conditions)	dB(A)	68	65	66	68
• Condensate quantity (natural gas ) at 50/30 °C	l/h	37	51	48	57
• pH value of the condensate (approx.)	pH	4.2	4.2	4.2	4.2
• Construction		B23, B23P, C53, C63			
• Flue gas system					
- Temperature class		T120	T120	T120	T120
- Flue gas mass flow at max. nominal heat input (dry)	kg/h	736	933	1055	1198
- Flue gas mass flow at min. nominal heat input (dry)	kg/h	112	196	211	238
- Flue gas temperature at max. nominal heat output and 80/60 °C	°C	66	68	69	66
- Flue gas temperature at max. nominal heat output and 50/30 °C	°C	44	47	49	44
- Flue gas temperature at min. nominal heat output and 50/30 °C	°C	28	28	29	28
- Max. permissible temperature of the combustion air	°C	48	48	48	48
- Combustion air flow rate	Nm <sup>3</sup> /h	602	764	863	981
- Maximum supply pressure for combustion air supply and flue gas line	Pa	130	130	130	130
- Maximum draught/underpressure at flue gas outlet	Pa	-30	-30	-30	-30

<sup>1)</sup> In relation to natural gas G20 (100 % methane). With a hydrogen content (H<sub>2</sub>) of up to 20 % by vol. in accordance with DVGW ZP3100 (D), an output reduction of up to 7 % is possible.

<sup>2)</sup> Data related to NCV, conditional data

<sup>3)</sup> Data related to NCV. The boiler series is tested for EE/H setting. With a factory setting to a Wobbe value of 15.0 kWh/m<sup>3</sup>, operation in the Wobbe value range from 12.0 to 15.7 kWh/m<sup>3</sup> is possible without resetting.

<sup>4)</sup> Conversion acc. to EN 15502-1, Appendix J

**Hoval UltraGas® 2 (1000-1550)**

Type		(1000)	(1100)	(1300)	(1550)
• Nominal heat output at 80/60 °C, natural gas <sup>1)</sup>	kW	185-926	203-1038	241-1230	297-1447
• Nominal heat output at 50/30 °C, natural gas <sup>1)</sup>	kW	205-999	229-1112	269-1320	324-1550
• Nominal heat output at 80/60 °C, propane <sup>2)</sup>	kW	262-926	299-1033	362-1227	427-1439
• Nominal heat output at 50/30 °C, propane <sup>2)</sup>	kW	282-999	316-1112	385-1320	453-1550
• Nominal heat input with natural gas <sup>3)</sup>	kW	187-943	206-1057	247-1251	297-1469
• Nominal heat input with propane <sup>2)</sup>	kW	265-943	306-1057	371-1251	437-1469
• Operating pressure heating min./max. (PMS)	bar	1/6	1/6	1/6	1/6
• Operating temperature max. (T <sub>max</sub> )	°C	95	95	95	95
• Boiler water content (V <sub>(H2O)</sub> )	l	756	718	1211	1118
• Flow resistance boiler		see diagram			
• Minimum circulation water quantity	l/h	-	-	-	-
• Boiler weight (without water capacity, incl. cladding)	kg	1580	1635	2280	2445
• Boiler efficiency at 80/60 °C in full-load operation (NCV/GCV) <sup>4)</sup>	%	98.2/88.5	98.2/88.5	98.2/88.5	98.2/88.5
• Boiler efficiency at 30 % partial load (NCV/GCV) <sup>4)</sup>	%	109.0/98.2	108.6/97.8	108.7/97.9	108.5/97.7
• Room heating energy efficiency					
- without control	ηs %	-	-	-	-
- with control	ηs %	-	-	-	-
- with control and room sensor	ηs %	-	-	-	-
- annual energy consumption	Q <sub>HE</sub> GJ	-	-	-	-
• NOx class (EN 15502)		6	6	6	6
• Nitrogen oxide emissions (EN 15502) (GCV)	NOx mg/kWh	36	41	37	35
• Carbon monoxide emissions at 50/30 °C (related to 3 % of O <sub>2</sub> )	CO mg/Nm <sup>3</sup>	25	26	23	23
• O <sub>2</sub> content in flue gas min./max. output	%	6.0/5.9	6.0/5.9	6.0/5.9	6.0/6.0
• Heat loss in standby mode (EN 15502) (50°C)	Watt	600	600	740	740
• Dimensions		see dimensional drawing			
• Gas flow pressure min./max.					
- Natural gas E/LL	mbar	17.4-300	17.4-300	17.4-300	17.4-300
- Propane	mbar	37-57	37-57	37-57	37-57
• Gas inlet pressure max. (idle pressure)	mbar	300	300	300	300
• Gas connection values at 15 °C/1013 mbar:					
- Natural gas E – (W <sub>o</sub> = 15.0 kWh/m <sup>3</sup> ) NCV = 9.7 kWh/m <sup>3</sup>	m <sup>3</sup> /h	19.3-97.2	21.2-109.0	25.5-129.0	30.6-151.4
- Natural gas LL (G25) – (W <sub>o</sub> = 12.4 kWh/m <sup>3</sup> ) NCV = 8.13 kWh/m <sup>3</sup>	m <sup>3</sup> /h	23.0-116.0	25.3-130.0	30.4-153.9	36.5-180.7
- Propane (G31) NCV = 24.4 kWh/m <sup>3</sup> <sup>2)</sup>	m <sup>3</sup> /h	10.9-38.6	12.5-43.3	15.2-51.3	17.9-60.2
• Operating voltage (50/60 Hz)	V	1 x 230 3 x 400	1 x 230 3 x 400	1 x 230 3 x 400	1 x 230 3 x 400
• Electrical power consumption min./max.	Watt	203-1873	203-1933	271/4111	301/4141
• Standby	Watt	7	7	5	7
• Type of protection	IP	20	20	20	20
• Permitted ambient temperature during operation	°C	5-40	5-40	5-40	5-40
• Sound power level					
- Heating noise (EN 15036 part 1) (room air dependent)	dB(A)	83	82	86	85
- Flue gas noise radiated from the mouth (DIN 45635 part 47) (room air dependent/independent of room air)	dB(A)	76	76	74	76
- Sound pressure level heating noise (reference value depending on installation conditions)	dB(A)	73	72	74	76
• Condensate quantity (natural gas ) at 50/30 °C	l/h	68	72	100	138
• pH value of the condensate (approx.)	pH	4.2	4.2	4.2	4.2
• Construction		B23, B23P, C53, C63			
• Flue gas system					
- Temperature class		T120	T120	T120	T120
- Flue gas mass flow at max. nominal heat input (dry)	kg/h	1488	1669	1975	2230
- Flue gas mass flow at min. nominal heat input (dry)	kg/h	295	325	390	450
- Flue gas temperature at max. nominal heat output and 80/60 °C	°C	69	70	66	68
- Flue gas temperature at max. nominal heat output and 50/30 °C	°C	47	49	45	46
- Flue gas temperature at min. nominal heat output and 50/30 °C	°C	28	29	29	28
- Max. permissible temperature of the combustion air	°C	48	48	48	48
- Combustion air flow rate	Nm <sup>3</sup> /h	1219	1366	1617	1830
- Maximum supply pressure for combustion air supply and flue gas line	Pa	130	130	130	130
- Maximum draught/underpressure at flue gas outlet	Pa	-30	-30	-30	-30

<sup>1)</sup> In relation to natural gas G20 (100 % methane). With a hydrogen content (H<sub>2</sub>) of up to 20 % by vol. in accordance with DVGW ZP3100 (D), an output reduction of up to 7 % is possible.

<sup>2)</sup> Data related to NCV, conditional data

<sup>3)</sup> Data related to NCV. The boiler series is tested for EE/H setting. With a factory setting to a Wobbe value of 15.0 kWh/m<sup>3</sup>, operation in the Wobbe value range from 12.0 to 15.7 kWh/m<sup>3</sup> is possible without resetting.

<sup>4)</sup> Conversion acc. to EN 15502-1, Appendix J

**Hoval UltraGas® 2 H (700-1550)**

Type		H (700)	H (1100)	H (1550)
• Nominal heat output at 80/60 °C, natural gas <sup>1)</sup>	kW	132-653	203-1038	297-1447
• Nominal heat output at 50/30 °C, natural gas <sup>1)</sup>	kW	146-703	229-1112	324-1550
• Nominal heat output at 80/60 °C, propane <sup>2)</sup>	kW	193-643	299-1033	427-1439
• Nominal heat output at 50/30 °C, propane <sup>2)</sup>	kW	208-703	316-1112	453-1550
• Nominal heat input with natural gas <sup>3)</sup>	kW	134-668	206-1057	297-1469
• Nominal heat input with propane <sup>2)</sup>	kW	201-668	306-1057	437-1469
• Operating pressure heating min./max. (PMS)	bar	1/10	1/10	1/10
• Operating temperature max. (T <sub>max</sub> )	°C	95	95	95
• Boiler water content (V <sub>(H2O)</sub> )	l	509	709	1118
• Flow resistance boiler			see diagram	
• Minimum circulation water quantity	l/h	-	-	-
• Boiler weight (without water capacity, incl. cladding)	kg	1170	1735	2550
• Boiler efficiency at 80/60 °C in full-load operation (NCV/GCV) <sup>4)</sup>	%	98.2/88.5	98.2/88.5	98.2/88.5
• Boiler efficiency at 30 % partial load (NCV/GCV) <sup>4)</sup>	%	108.9/98.1	108.6/97.8	108.5/97.7
• Room heating energy efficiency				
- without control	η <sub>s</sub> %	-	-	-
- with control	η <sub>s</sub> %	-	-	-
- with control and room sensor	η <sub>s</sub> %	-	-	-
- annual energy consumption	Q <sub>HE</sub> GJ	-	-	-
• NOx class (EN 15502)		6	6	6
• Nitrogen oxide emissions (EN 15502) (GCV)	NOx mg/kWh	40	41	35
• Carbon monoxide emissions at 50/30 °C (related to 3 % of O <sub>2</sub> )	CO mg/Nm <sup>3</sup>	26	26	23
• O <sub>2</sub> content in flue gas min./max. output	%	6.0/5.7	6.0/5.9	6.0/6.0
• Heat loss in standby mode (EN 15502) (50 °C)	Watt	540	600	740
• Dimensions		see dimensional drawing		
• Gas flow pressure min./max.				
- Natural gas E/LL	mbar	17.4-80	17.4-300	17.4-300
- Propane	mbar	37-57	37-57	37-57
• Gas inlet pressure max. (idle pressure)	mbar	80	300	300
• Gas connection values at 15 °C/1013 mbar:				
- Natural gas E – (Wo = 15.0 kWh/m <sup>3</sup> ) NCV = 9.7 kWh/m <sup>3</sup>	m <sup>3</sup> /h	13.8-68.9	21.2-109.0	30.6-151.4
- Natural gas LL (G25) – (Wo = 12.4 kWh/m <sup>3</sup> ) NCV = 8.13 kWh/m <sup>3</sup>	m <sup>3</sup> /h	16.5-82.2	25.3-130.0	36.5-180.7
- Propane (G31) NCV = 24.4 kWh/m <sup>3</sup> <sup>2)</sup>	m <sup>3</sup> /h	8.2-27.4	12.5-43.3	17.9-60.2
• Operating voltage (50/60 Hz)	V	1 x 230	1 x 230 3 x 400	1 x 230 3 x 400
• Electrical power consumption min./max.	Watt	67/1060	203/1933	301/4141
• Standby	Watt	5	7	7
• Type of protection	IP	20	20	20
• Permitted ambient temperature during operation	°C	5-40	5-40	5-40
• Sound power level				
- Heating noise (EN 15036 part 1) (room air dependent)	dB(A)	76	82	85
- Flue gas noise radiated from the mouth (DIN 45635 part 47) (room air dependent/independent of room air)	dB(A)	71	76	76
- Sound pressure level heating noise (reference value depending on installation conditions)	dB(A)	66	72	76
• Condensate quantity (natural gas ) at 50/30 °C	l/h	48	72	138
• pH value of the condensate (approx.)	pH	4.2	4.2	4.2
• Construction		B23, B23P, C53, C63		
• Flue gas system				
- Temperature class		T120	T120	T120
- Flue gas mass flow at max. nominal heat input (dry)	kg/h	1055	1669	2230
- Flue gas mass flow at min. nominal heat input (dry)	kg/h	211	325	450
- Flue gas temperature at max. nominal heat output and 80/60 °C	°C	69	70	68
- Flue gas temperature at max. nominal heat output and 50/30 °C	°C	49	49	46
- Flue gas temperature at min. nominal heat output and 50/30 °C	°C	29	29	28
- Max. permissible temperature of the combustion air	°C	48	48	48
- Combustion air flow rate	Nm <sup>3</sup> /h	863	1366	1830
- Maximum supply pressure for combustion air supply and flue gas line	Pa	130	130	130
- Maximum draught/underpressure at flue gas outlet	Pa	-30	-30	-30

<sup>1)</sup> In relation to natural gas G20 (100 % methane). With a hydrogen content (H<sub>2</sub>) of up to 20 % by vol. in accordance with DVGW ZP3100 (D), an output reduction of up to 7 % is possible.

<sup>2)</sup> Data related to NCV, conditional data

<sup>3)</sup> Data related to NCV. The boiler series is tested for EE/H setting. With a factory setting to a Wobbe value of 15.0 kWh/m<sup>3</sup>, operation in the Wobbe value range from 12.0 to 15.7 kWh/m<sup>3</sup> is possible without resetting.

<sup>4)</sup> Conversion acc. to EN 15502-1, Appendix J

Flow resistance on the heating water side

UltraGas® 2 (125,150)

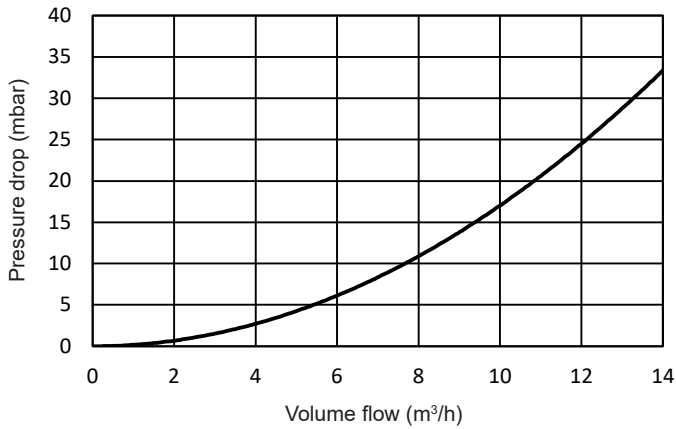

UltraGas® 2 (190,230)

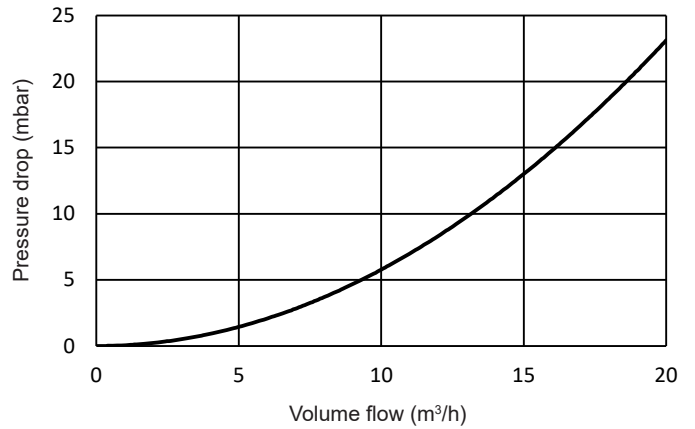

UltraGas® 2 (300-500)

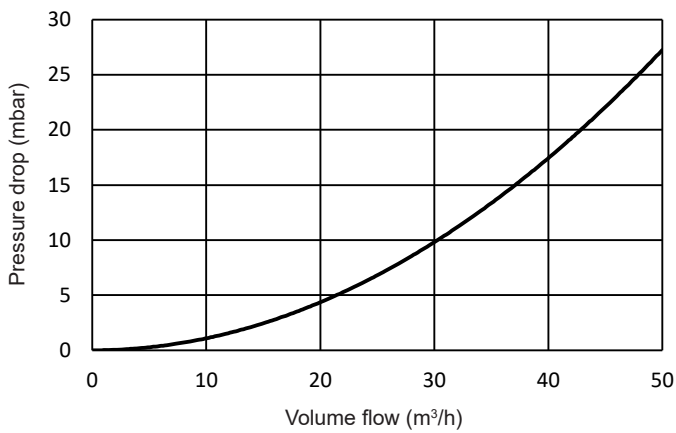

UltraGas® 2 (620,700)

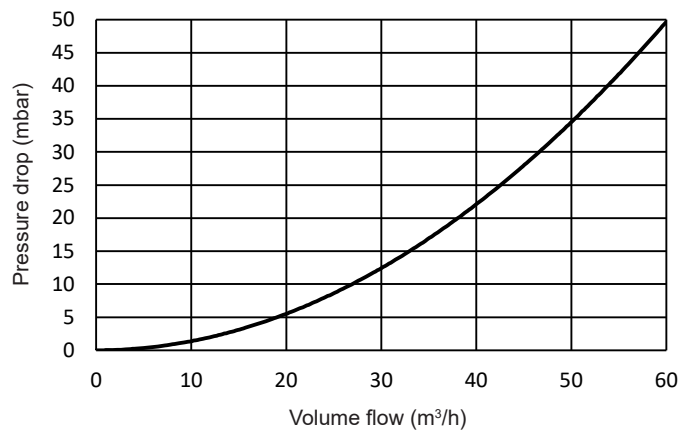

UltraGas® 2 (800-1100)

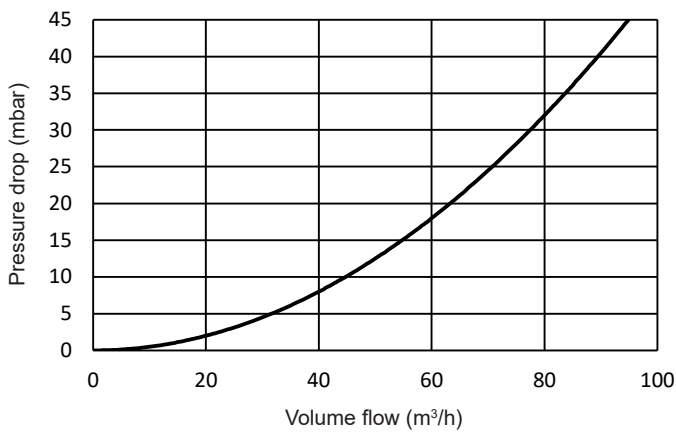

UltraGas® 2 (1300,1550)

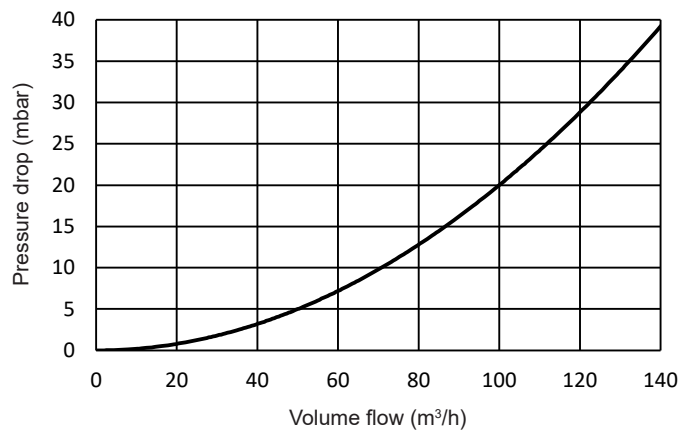

**UltraGas® 2 (125-1550)**  
(Dimensions in mm)

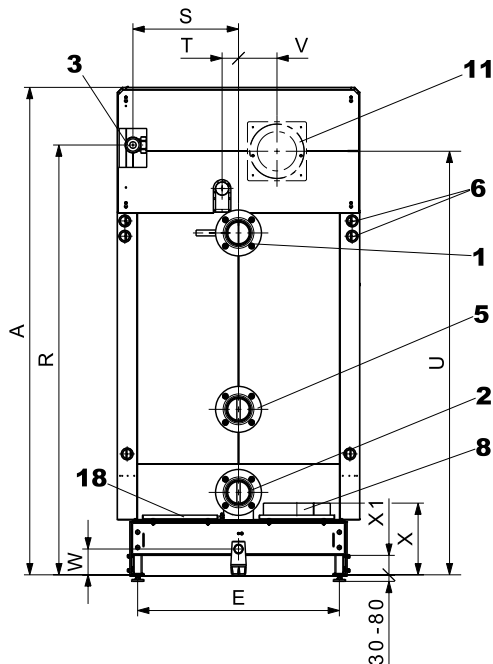
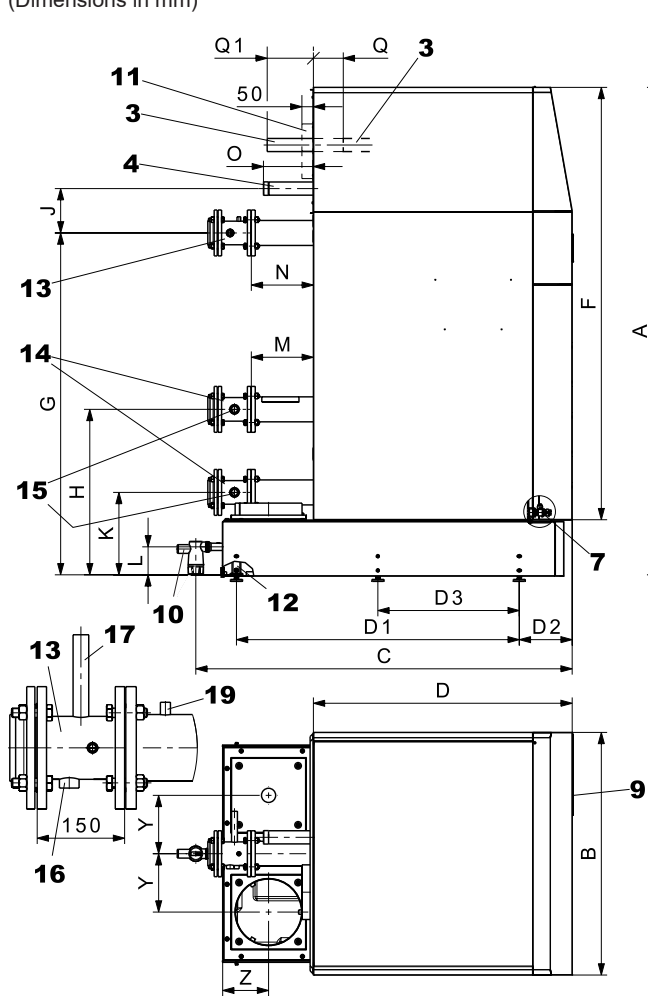

- 1 Flow heating
- 2 Low temperature return
- 3 Gas connection
- 4 Safety flow (safety valve, air vent)
- 5 High temperature return
- 6 Electrical connection left or right
- 7 Draining (behind the front casing)
- 8 Flue gas connector left or right
- 9 Control panel
- 10 Condensate drain with screw including siphon for plastic tube
- 11 Combustion air suction socket (option)
- 12 Boiler feet (adjustable 30-80 mm)
- 13 Safety fitting pipe flow (option)
- 14 Safety fitting pipe return (option)
- 15 Diaphragm pressure expansion tank connection Rp 1"
- 16 Pressure limiter Rp 3/4"
- 17 Safety temperature control Rp 1/2"
- 18 Cleaning opening left or right
- 19 Flow connection sleeve Rp 1/4" for installation of the system flow sensor

**Notice**

Minimal space see separate page

Type	A	B	C	D	D1	D2	D3	E	F	G	H	J	K	L	M	N	O	Q	Q1	R
(125,150)	1923	720	1182	799	754	242	-	533	1681	1479	714	122	334	134	207	207	65	192	-	1725
(190,230)	1968	820	1256	895	854	242	-	633	1726	1517	717	145	337	134	204	204	69	226	-	1778
(300-500)	1923	930	1632	1165	1204	242	-	743	1683	1447	745	169	365	131	285	285	189	-	190	1735
(620,700)	2234	1110	1722	1184	1294	242	-	923	1982	1564	757	203	377	128	286	286	225	0	0	1966
(800-1100)	2255	1290	1822	1364	1480	242	-	1103	1987	1573	788	215	408	128	378	378	225	58	-	1959
(1300,1550)	2395	1560	2200	1640	1790	250	895	1363	2103	1600	822	238	442	138	420	420	218	22	-	2064
H (700)	2234	1110	1722	1184	1294	242	-	923	1982	1564	757	203	377	128	286	286	225	0	0	1966
H (1100)	2255	1290	1822	1364	1480	242	-	1103	1987	1573	788	215	408	128	378	378	225	58	-	1959
H (1550)	2395	1560	2200	1640	1790	250	895	1363	2103	1600	822	238	442	138	390	390	218	22	-	2064

Type	S	T	U	V	W	X	X1	Y	Z	1,25 *	3	4	8	10	11
(125,150)	318	40	1725	101	124	319	99	157	139	DN 65 / PN 6 / 4-hole	Rp 1"	R 1"	Ø 155/159	DN 40	Ø 122/125
(190,230)	371	50	1778	101	124	319	99	195	139	DN 65 / PN 6 / 4-hole	Rp 1 1/2"	R 1 1/4"	Ø 155/159	DN 40	Ø 197/200
(300-500)	389	40	1736	101	121	316	96	217	184	DN 100 / PN 6 / 4-hole	Rp 1 1/2"	R 1 1/2"	Ø 252/256	DN 40	Ø 197/200
(620,700)	483	75	1938	176	118	328	89	267	211	DN 100 / PN 6 / 4-hole	Rp 2"	R 2"	Ø 302/306	DN 40	Ø 247/250
(800-1100)	572	100	1959	176	118	374	89	357	219	DN 125 / PN 6 / 8-hole	Rp 2"	R 2"	Ø 302/306	DN 40	Ø 247/250
(1300,1550)	621	100	2064	190	128	398	89	455	244	DN 150 / PN 6 / 8-hole	Rp 2"	R 2"	Ø 402/406	DN 40	Ø 247/250
H (700)	483	75	1938	176	118	328	89	267	211	DN 100 / PN 16 / 8-hole	Rp 2"	R 2"	Ø 302/306	DN 40	Ø 247/250
H (1100)	572	100	1959	176	118	374	89	357	219	DN 125 / PN 16 / 8-hole	Rp 2"	R 2"	Ø 302/306	DN 40	Ø 247/250
H (1550)	621	100	2064	190	128	398	89	455	244	DN 150 / PN 16 / 8-hole	Rp 2"	R 2"	Ø 402/406	DN 40	Ø 247/250

\* DN = nominal diameter, PN = nominal pressure

**Installation dimensions**

Boiler without cladding and thermal insulation  
(Dimensions in mm)

**UltraGas® 2 (125-1550)**

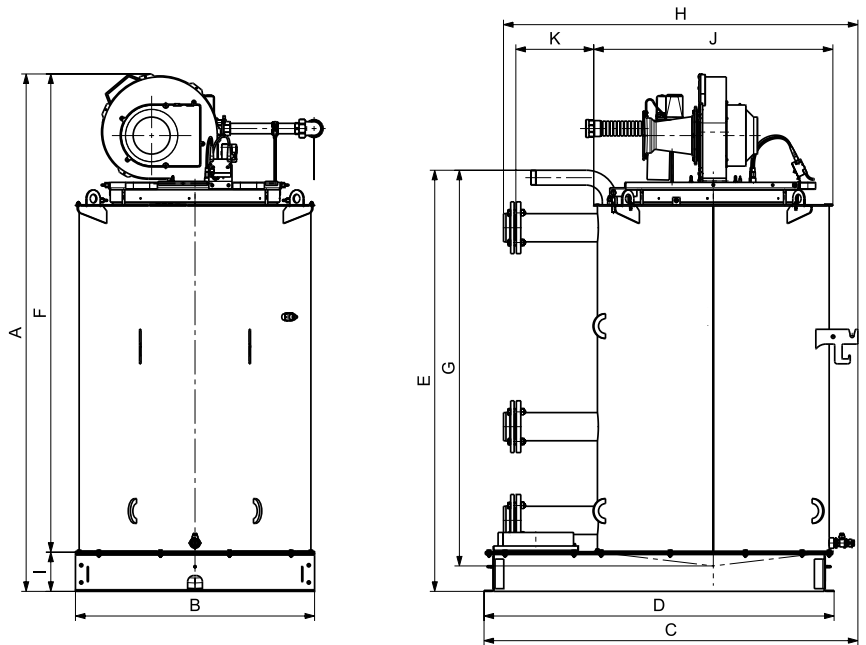

UltraGas® 2 type	A	B	C	D	E	Dimensions for multi-part installation					
						F	G	H	I	J	K
(125,150)	1765	580	957	880	1519	1625	1421	946	140	580	242
(190,230)	1818	680	1054	980	1583	1678	1484	1037	140	680	236
(300-500)	1777	790	1400	1330	1544	1637	1451	1391	140	950	316
(620,700)	2099	970	1516	1420	1708	1940	1605	1437	159	970	316
(800-1100)	2120	1150	1712	1606	1729	1945	1625	1722	175	1150	408
(1300,1550)	2255	1410	2032	1916	1779	2056	1671	2042	199	1410	458

**Weights for multi-part installation UltraGas® 2**

UltraGas® 2 type	Base kg	Heat exchanger kg	Burner kg
(125)	34	207	29
(150)	34	220	29
(190)	42	272	39
(230)	42	293	39
(300)	60	455	60
(350)	60	486	60
(400)	60	520	60
(450)	60	554	60
(500)	60	576	60
(620)	86	729	80
(700)	86	777	80
(800)	104	1017	93
(1000)	104	1154	100
(1100)	104	1208	100
(1300)	155	1683	160
(1550)	155	1847	160

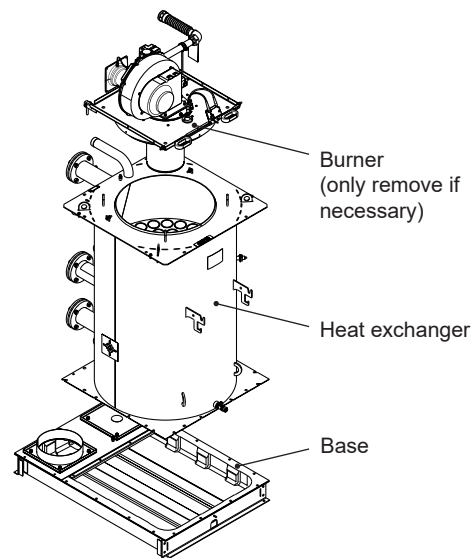

**Required minimum width of door and corridor for boiler installation**

The following values are the calculated minimum values (dimensions in mm)

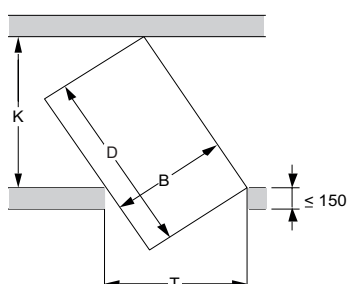

$$K = \frac{B}{T} \times D$$

$$T = \frac{B}{K} \times D$$

- B = boiler width
- D = max. boiler length
- T = door width
- K = corridor width

**Calculation example for the necessary corridor width**

Door width T = 800

UltraGas® 2 (500)  $K = \frac{790}{800} \times 1330 = \text{corridor width} \geq 1314$

Space requirements

(Dimensions in mm)

UltraGas® 2 (125-1550)

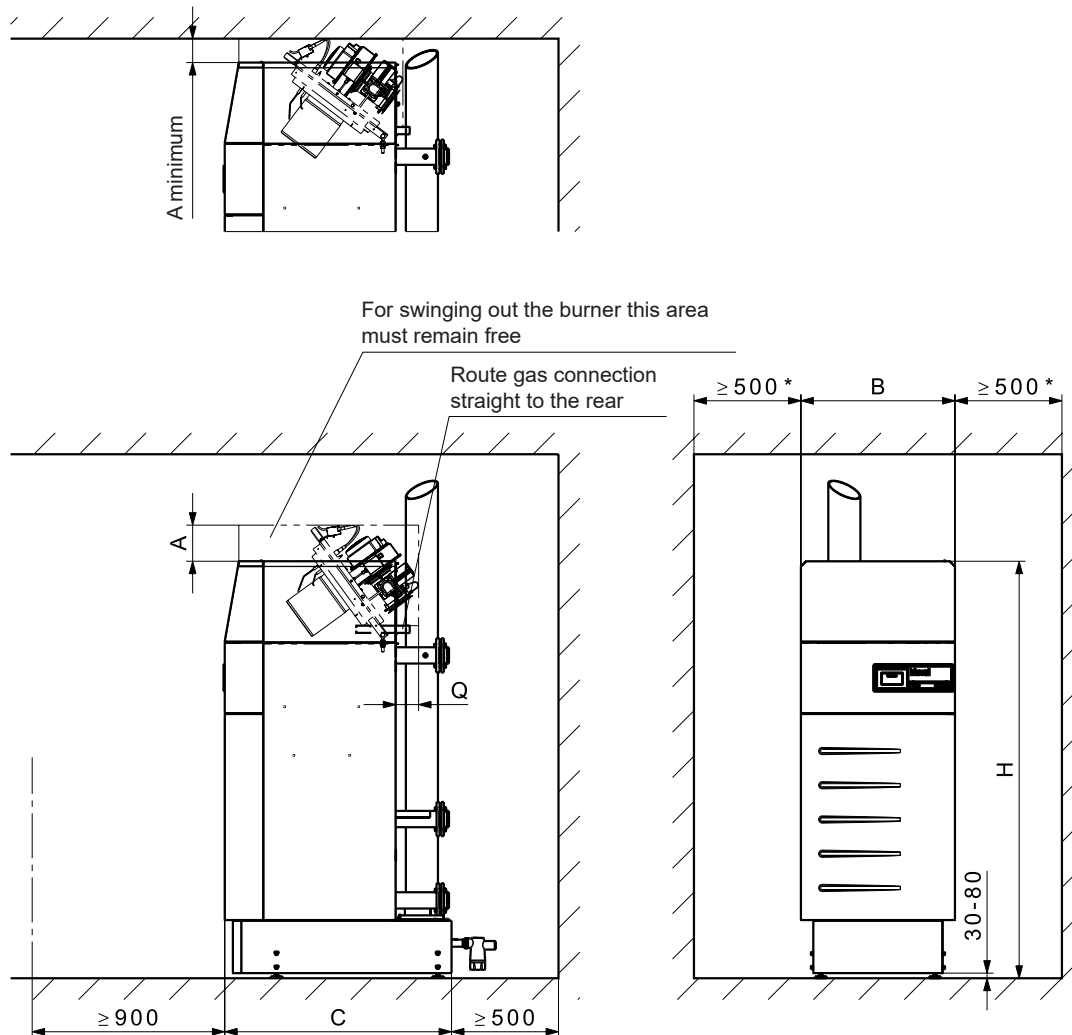

UltraGas® 2

type	A <sup>1)</sup>	A minimum <sup>2)</sup>	B	C	H <sup>3)</sup>	H minimum <sup>4)</sup>	Q
(125,150)	169	106	720	1060	1953	1934	125
(190,230)	155	71	820	1160	1998	1979	2
(300-500)	513	156	930	1510	1953	1937	60
(620,700)	121	121	1110	1600	2264	2255	155
(800-1100)	280	195	1290	1786	2285	2276	119
(1300,1550)	291	154	1560	2104	2425	2416	163
H (700)	121	121	1110	1600	2264	2255	155
H (1100)	280	195	1290	1786	2285	2276	119
H (1550)	291	154	1560	2104	2425	2416	163

<sup>1)</sup> If room height is too small: Reduction of dimension possible (see A minimum).

<sup>2)</sup> **Attention!** With A minimum the burner can not be swung out completely anymore!  
Cleaning with UltraGas® 2 (125-230) and UltraGas® 2 (620-1550) still possible

<sup>3)</sup> Height value assumes adjustable feet are set to 30 mm

<sup>4)</sup> The base plates cannot be installed without feet and the installer will have to fit a siphon with min. 70 mm barrier height. For details see next page.

- The heat generator can be placed with one side directly on the wall. However, to protect heat-sensitive walls against damage, a distance of at least 150 mm from the wall must be provided.
- The cleaning opening must be easily accessible. As a result, a minimum distance of 500 mm must be maintained on the cleaning opening side.

**UltraGas® 2 (125-1550) with masonry base and adjustable feet**  
(Dimensions in mm)

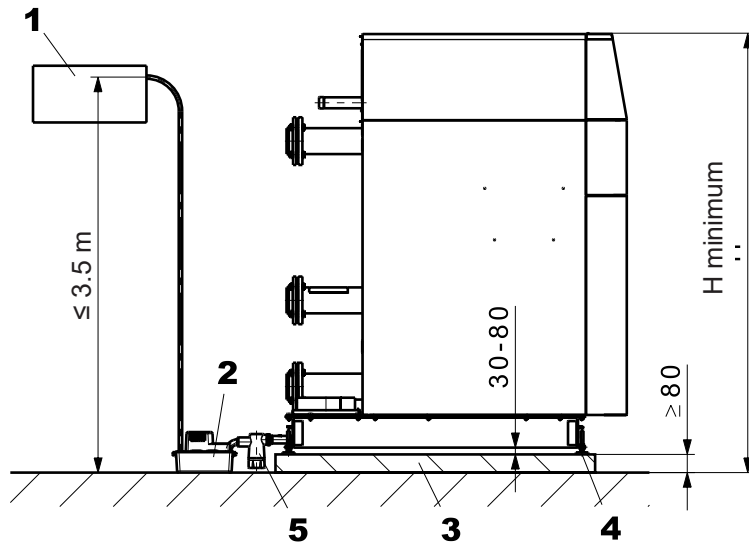

UltraGas® 2 type	H minimum <sup>1)</sup>
(125,150)	1934
(190,230)	1979
(300-500)	1937
(620,700)	2255
(800-1100)	2276
(1300,1550)	2416
H (700)	2255
H (1100)	2276
H (1550)	2416

**UltraGas® 2 (125-1550) with masonry base without adjustable feet**

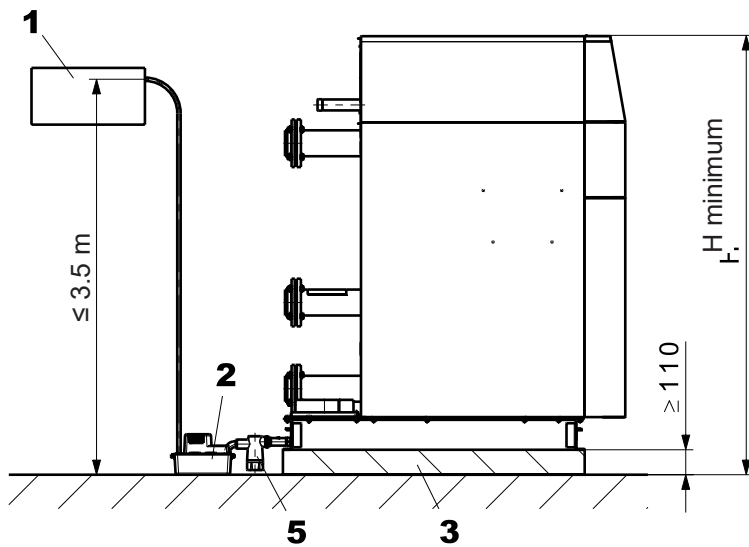

UltraGas® 2 type	H minimum <sup>1)</sup>
(125,150)	1934
(190,230)	1979
(300-500)	1937
(620,700)	2255
(800-1100)	2276
(1300,1550)	2416
H (700)	2255
H (1100)	2276
H (1550)	2416

- 1 Neutralisation unit (option)
- 2 Condensate pump (option)
- 3 Masonry base
- 4 Feet adjustable up to 30-80 mm
- 5 Siphon <sup>2)</sup>

<sup>1)</sup> Height value assumes adjustable feet are set to 30 mm  
<sup>2)</sup> **Caution!** The installer will have to fit a siphon with min. 70 mm barrier height.

**Notice**

- The steps of the climbing aid provided must be horizontal. Adapt the climbing aid if necessary.
- Base plates and feeds will not be refunded!
- With H minimum, cleaning the siphon is more difficult.

**Neutralisation unit HNB-0400 to HNB-1600**  
(Dimensions in mm)

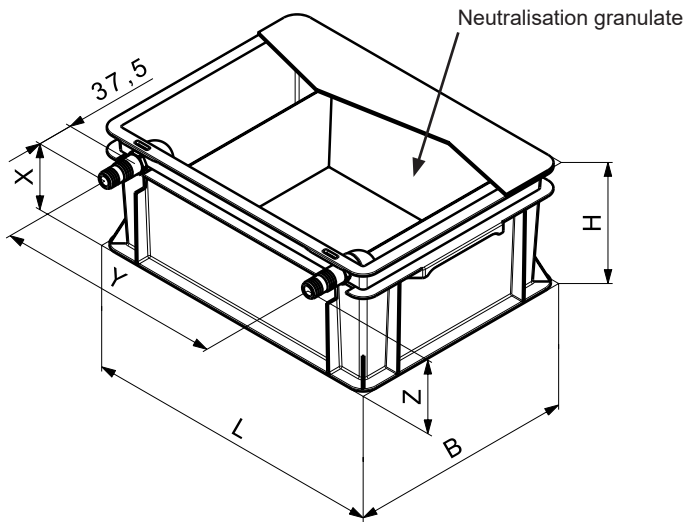

	HNB-0400,-0800	HNB-1200,-1600
Dimensions (L x W x H)	405 x 300 x 180 mm	605 x 400 x 180 mm
Inlet height (Z)	128 mm	
Drain height (X)	118 mm	
Distance between the connections (Y)	approx. 350 mm	approx. 550 mm

**Neutralisation unit HNB-0400,-0800 and condensate pump**  
(Dimensions in mm)

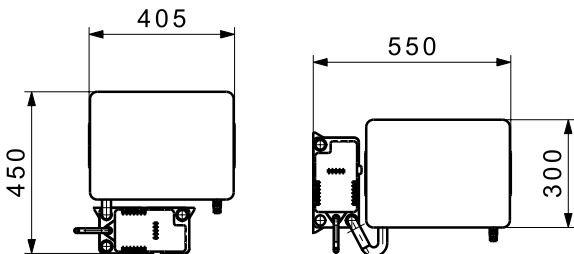

**Neutralisation unit HNB-1200,-1600 and condensate pump**  
(Dimensions in mm)

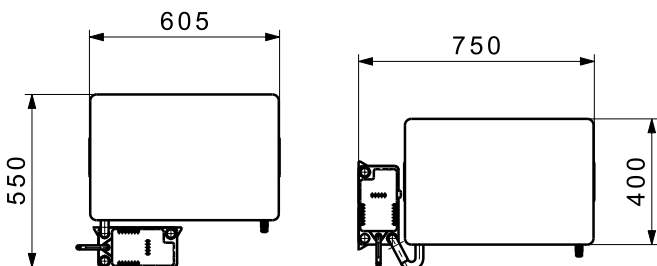

**Gas ball valves TAS (thermally activating shut-off device) with flange**  
 (Dimensions in mm)

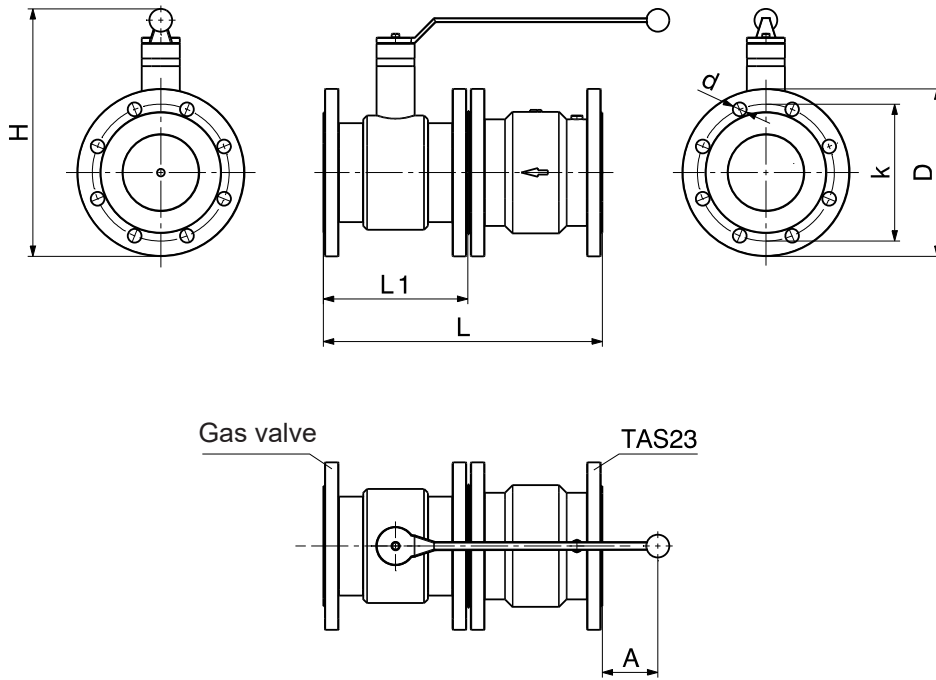

TAS type	L	L1	H	D	k	d/number of flange holes	A
DN 65	297	170	262.8	185	145	18/4	3
DN 80	307	180	298.3	200	160	18/8	128
DN 100	367	190	325.3	218	180	18/8	73

### Standards and guidelines

The official regulations for installation and operation must be observed. In particular, these are the country-specific standards (e.g. EN standard, DIN standards, etc.) as well as the corresponding regional regulations.

The following standards and guidelines must be complied with:

- Hoval technical information and installation instructions
- hydraulic and technical control regulations of Hoval
- DVGW directives
- DIN EN 12828  
Safety-relevant requirements
- DIN EN 12831 Heaters  
Rules for the calculation of the heat requirements of buildings
- VDI 2035  
Protection against damage by corrosion and boiler scale formation in heating and service water installations
- EN 14868  
"Protection of metallic materials against corrosion"
- VDE 0100 supplement 2

### Water quality in heating systems

#### Filling and replacement water, heating water

##### The following applies:

- VDI 2035
- In addition, the EN 14868 standard must be applied, **as well as the manufacturer-specific specifications**

#### Manufacturer-specific specifications

##### Filling and replacement water

The filling and replacement water can be both fully demineralised and also merely softened.

##### Heating water

- In the case of **full demineralisation of the filling and replacement water**, the electrical conductivity of the heating water must not exceed the value of 100 µS/cm.
- In the case of **softening the filling and replacement water**, the following conditions must be complied with:  
The quality of the heating water must be checked and documented periodically:
  - For an installed heat output above 100 kW up to and including 1000 kW, an annual check of the heating water is required.
  - For an installed heat output above 1000 kW, an check of the heating water is required twice a year.
 The following standard values for the heating water must be measured and adhered to:
  - Electrical conductivity of the heating water for operation with water containing salts: > 100 µS/cm to ≤ 1500 µS/cm
  - pH value of the heating water for systems without aluminium alloy as water-side material 8.2 to 10.0 (measurement 10 weeks after commissioning at the earliest)
- The sum of the chloride, nitrate and sulphate contents in the heating water must not exceed 50 mg/l in total.

### Additional notices

- Hoval boilers and calorifiers are suitable for heating systems without significant oxygen intake. (System type I according to EN 14868).
- Plants with continual oxygen intake (e.g. underfloor heating without diffusion-proof plastic piping) or intermittent oxygen intake (e.g. requiring frequent topping-up) must be equipped with a system separation.
- In the case of bivalent heating systems, the values of the heat generator with the strictest requirement for water quality must be complied with.
- If only the boiler is replaced in an existing plant, it is not recommended for the entire heating system to be refilled, provided that the heating water already contained in the system complies with the relevant directives or standards.
- Before filling new systems and, where necessary, existing heating systems containing heating water that does not comply with the directives or standards, the heating system must be professionally cleaned and flushed. The boiler must not be filled until the heating system has been flushed.

### Frost protection agent

see separate engineering sheet  
"Use of frost protection agent".

### Heating room

- Boilers cannot be positioned in rooms in which halogen compounds can occur and into which combustion air can enter (e.g. laundrettes, hairdressers).
- Halogen compounds can be caused by cleaning and degreasing solutions, solvents, glue and bleaching lyes. Pay attention to the Procal leaflet, corrosion through Halogen compounds.

### Combustion air supply

The supply of combustion air must be guaranteed. There must be no possibility to close the air supply opening. For direct combustion air to boiler (LAS system) mount the connection for direct combustion air inlet. It is very important to ensure that the combustion air is free from halogen compounds. These are present, for example, in spray cans, varnishes, glues, solvents and cleansing agents.

The minimum free cross-section for the combustion air can be assumed simplified as follows:

- **Room air-independent operation with separate combustion air pipe to the boiler:** 0.8 cm<sup>2</sup> per 1 kW of output. The pressure drop in the combustion air pipe must be considered for the calculation of the flue gas system.
- In the UltraGas® 2, ventilation of the installation or boiler room must be guaranteed for operation independent from the room air.
- **Room air-dependent operation:** Minimum free cross-section of the opening into the open: 150 cm<sup>2</sup> or twice 75 cm<sup>2</sup> and additionally 2 cm<sup>2</sup> necessary for each kW of output over 50 kW for vent into the open.

### Gas connection

#### Commissioning

- Initial commissioning must be performed by a specialist technician from Hoval or a gas specialist technician.
- Burner setting values according to the installation instructions.

#### Manual gas shut-off valve and gas filter





Immediately in front of the boiler a manual gas shut-off device (valve) must be installed according to relevant regulations.

In the UltraGas® 2 (400-1550) type, an external gas filter must be installed in the gas supply line.  
Make sure that the gas line from the external gas filter to the gas connection of the boiler is cleaned.  
For the UltraGas® (125-350) types, it is necessary to comply with the local regulations concerning the need for a gas filter.

#### Construction of a recommended gas connection



#### Legend:

-  manual gas shut-off valve
-  gas hose/compensator
-  gas filter
-  pressure gauge with test burner and push-button valve

#### Type of gas

- The boiler is only to be operated with the type of gas stated on the rating plate.

#### Gas pressure natural gas

Necessary gas flow pressure at the boiler inlet:  
UltraGas® 2 (125-700) min. 17.4 mbar, max. 80 mbar  
UltraGas® 2 (800-1550) min. 17.4 mbar, max. 300 mbar

#### Gas pressure propane

- A gas pressure controller to reduce the boiler inlet pressure must be installed on-site for propane.
- Necessary gas flow pressure at the boiler inlet: UltraGas® 2 (125-1550) min. 37 mbar, max. 50 mbar

#### Gas pressure regulator

- The installation of a gas pressure regulator is only necessary if the gas flow pressure in the gas network exceeds the maximum permissible gas flow pressure of the UltraGas® 2 or if there are considerable fluctuations in the gas flow pressure.
- Pressure fluctuations in the gas network must be prevented by suitable measures (e.g. gas storage tanks or pressure regulators). The local conditions must be checked in each individual case.

### Closed heating system

The boiler is only approved for use in closed heating systems.

### Minimum circulation water quantity

No minimum water circulation volume is required.

### Calorifier connection

If a calorifier is connected, all heating groups must be provided with a mixer.

### Installation instructions

Please observe the installation instructions supplied with every boiler.

### Space requirements

See "Dimensions" for information

### Pump follow-on

For operating temperatures of the boiler above 85 °C, after each burner switch-off, the circulating pump must be in operation for at least 2 minutes (the pump after-run is included in the boiler controller with TopTronic® E control).

### Heating boiler in the attic

If the gas boiler is positioned on the top floor, the installation of a low water protection, which automatically turns the gas burner off in case of water shortage, is recommended.

### Condensate drain

- A permit for discharge of the flue gas condensate into the sewage system must be obtained from the relevant authority or sewer operator.
- The condensate from the flue gas line can be discharged via the boiler. A condensate trap is no longer needed in the flue gas system.
- The condensate must be conducted openly (funnel) into the sewage system.
- Suitable materials for condensate drain:
  - stoneware pipes
  - pipes made from glass
  - pipes made from stainless steel
  - pipes made from plastic: PVC, PE, PP, ABS and UP
- A siphon must be installed at the condensate outlet on the gas boiler (included in the boiler scope of delivery).

### Diaphragm pressure expansion tank

- An adequately dimensioned diaphragm pressure expansion tank must be provided.
- The diaphragm pressure expansion tank has to be installed in principle at the heating return, or at the safety flow.
- Starting from 70 °C an intermediate tank is necessary.

### Safety valve

- At the safety flow a safety valve and an automatic exhauster must be installed.

### Noise damping

The following measures are possible for sound insulation:

- Make boiler room walls, ceiling and floor as solid as possible.
- If there are living areas above or below the boiler room, connect pipes flexibly using expansion joints.
- Connect circulating pumps to the piping network using expansion joints

### Noise level

- The acoustic **power** level value is dependent on the local and spacial circumstances.
- The acoustic **pressure** level is dependent on the installation conditions and can for instance be 5 to 10 dB(A) lower than the acoustic **power** level at a distance of 1 m.

#### Recommendation:

If the combustion air intake opening is located on the house facade near a noise-sensitive place (window of bedroom, garden terrace, etc.), we recommend using a silencer in the combustion air duct.

### Allocation of gas filters for UltraGas® 2

UltraGas® 2 type	Gas throughput m³/h	Gas filter type	Dimension	Pressure drop gas filter (with clean filter) mbar
(125)	11.9	70602/6B	Rp 1"	0.2
(150)	14.2	70602/6B	Rp 1"	0.3
(190)	18.0	70603/6B	Rp 1½"	0.2
(230)	22.4	70603/6B	Rp 1½"	0.2
(300)	29.2	70603/6B	Rp 1½"	0.3
(350)	33.9	70603/6B	Rp 1½"	0.4
(400)	38.6	70603/6B	Rp 1½"	0.6
(450)	44.0	70603/6B	Rp 1½"	0.7
(500)	46.4	70631/6B	Rp 2"	0.5
(620)	59.3	70631/6B	Rp 2"	0.7
(700)	67.0	70631/6B	Rp 2"	0.8
(800)	76.1	70631/6B	Rp 2"	0.9
(1000)	94.6	70631/6B	Rp 2"	1.4
(1100)	106.0	70631/6B	Rp 2"	1.6
(1300)	125.5	70610F/6B	DN 65	1.5
(1550)	147.3	70610F/6B	DN 65	2.1

**Flue gas system**

- Gas boilers must be connected to a flue gas system (chimney or flue gas lines).
- Flue gas lines must be gas tight and leak tight against condensate and over pressure.
- The flue gas lines must be secured against unwanted loosening of the plug connections.
- The flue gas system must be connected with an angle, so that the resulting condensate of the flue gas system can flow back to the boiler and can be neutralised there before discharging into the canalisation.
- Gas boilers with condensation heat utilisation are to be connected to a flue gas line min. Temperature class T120.
- A flue gas temperature limiter is built into the boiler.

**Standard values for**

**flue gas line dimensions**

Standard values for the flue gas line dimensions can be found in the following table.

**Table with bases for calculation**

- Calculation based on max. 1000 m above sea level.
- Installation room with supply air opening (room air dependent operation)
- An individual calculation must be carried out for room air-independent operation (accessories as option) or a combustion air supply via a duct.
- Connecting line was calculated with max. 5 m.

• The first 2 m of the flue gas line must be configured with the same dimension as the flue gas connector, after which the size of the flue gas system can be selected according to the table below.

**Table “Standard values for flue gas line dimensions”**

UltraGas® 2 type	Boiler	Flue gas line (smooth walled) Designation DN	Number of elbows 90° (flue gas + combustion air) Total pipe length in m (flue gas + combustion air)			
	Internal Ø flue gas outlet mm		1	2	3	4
(125)	155	130	24	23	22	21
(150)	155		18	17	16	15
(125)	155	150	47	47	46	45
(150)	155		45	45	45	44
(190)	155		43	42	40	38
(230)	155		20	20	19	18
(230)	155	175	44	43	43	42
(230)	155	200	45	44	43	43
(300)	252		45	44	43	43
(350)	252		44	43	43	42
(400)	252	250	44	43	42	41
(450)	252		50	50	50	50
(500)	252		50	50	50	50
(620)	302		43	42	41	40
(700)	302		42	41	40	39
(800)	302	300	45	44	43	43
(1000)	302		44	43	43	42
(1100)	302	350	47	46	45	44
(1300)	402		46	45	44	43
(1550)	402		45	44	43	43
H (700)	302	250	42	41	40	39
H (1100)	302	350	47	46	45	44
H (1550)	402		45	44	43	43

Notice: The values in the table “Standard values for flue gas line dimensions” are standard values for reference.

An exact calculation for the flue gas duct must be made on-site.

For chimney systems above 25 m effective height, negative pressure in the chimney is to be expected in some operating conditions.

Therefore, we recommend an individual design of the chimney system and checking the individual pressure conditions.

**Hoval quality.**  
You can count on us.

Hoval is one of the leading international companies for heating and indoor climate solutions. Drawing on more than 80 years of experience and benefiting from a close-knit team culture, the Hoval Group delivers exciting solutions and develops technically superior products. This leadership role requires a sense of responsibility for energy and the environment, which is expressed in an intelligent combination of different heating technologies and customised indoor climate solutions.

Hoval also provides personal consultations and comprehensive customer service. With around 2500 employees in 15 companies around the world, Hoval sees itself not as a conglomerate, but as a large family that thinks and acts globally.

Hoval heating and indoor climate solutions are currently exported to more than 50 countries.

## Responsibility for energy and environment

Your Hoval partner

### **Liechtenstein**

Hoval Aktiengesellschaft  
9490 Vaduz  
+423 399 24 00  
hoval.com

### **United Kingdom**

Hoval Ltd.  
Newark Notts. NG 24 1JN  
+44 1636 672 711  
hoval.co.uk